

Features & Benefits

- **Compact size** ... ideal for limited space applications.
- **Sealed for submersibility** ... assures long-term reliability in the most hostile environments.
- **Tamper-resistant** ... cannot be bypassed with simple magnets.
- **Rugged, corrosion-resistant housing** ... tolerates most industrial environments.
- **Integral LED status indicators** ... facilitate easy installation and provide visual indication of switch status.
- **Shock and vibration tolerant** ... designed to withstand mechanical abuse.
- **Satisfy CE & fail-to-safe requirements** ... when used with Series AES safety controllers.

Description

The Series BNS250 coded-magnet sensors are designed for use as a safety interlock switch on movable machine guards/articulating robot arms. Each sensor set consists of a multiple reed switch unit and a coded-magnet actuator. The reed switches, wired in series, will only close in the presence of their matched magnetic field array.

Both switch and magnet assemblies are sealed to IP67 (submersible) standards. Their tamper-resistant design prevents bypassing with a simple magnet or improperly coded magnetic field. In addition, the BNS module features a 1-meter long prewired pigtail.

Operation

The reed switch assembly is typically mounted to a stationary portion of a guard structure, with the coded-magnet assembly mounted to the movable element of the machine guard. When the guard is closed, and the matched magnetic field aligns with the reed switch unit, the switches will close. When the guard is open, or the required magnetic-field array is not properly aligned with the reed switch assembly, the sensor output will remain "off."

Typical Applications



The sealed, compact BNS250 is ideal for use on movable machine guards in hostile environments. Typical applications include food processing equipment, chemical processing equipment, woodworking machinery, packaging machinery, and articulating robot arm rest position sensing.

AVAILABLE STANDARD MODELS

(Please order BPS250 magnet separately)

Part Number	Contact Configuration*	Description
BNS250-11z	1 NO & 1 NC	Multiple reed switch (100VAC/DC) assembly with 1-meter prewired pigtail
BNS250-12z	1 NO & 2 NC	Multiple reed switch (100VAC/DC) assembly with 1-meter prewired pigtail
BNS250-11zG	1 NO & 1 NC	Multiple reed switch (24VDC/10mA) assembly with 1 meter prewired pigtail and built-in LED display
BNS250-12zG	1 NO & 2 NC	Multiple reed switch (24VDC/10mA) assembly with 1 meter prewired pigtail and built-in LED display
BNS250-11zG-2205 (side entry cable)	1 NO & 1 NC	Multiple reed switch (24VDC/10mA) assembly with 5 meter pigtail (side entry) and built-in LED display
BPS250	N/A	Coded-magnet actuator

*Contact configuration in presence of BPS250 coded-magnet actuator.

***Important Note:** Series BNS Coded-magnet sensors are for use in safety applications only when used with a SCHMERSAL Series AES safety controller. (Please see selection chart on Page 159.)



USE WITH ANY OTHER SAFETY CONTROLLER MAY DAMAGE SENSOR AND/OR VOID WARRANTY.

BNS250 TECHNICAL DATA

MECHANICAL SPECIFICATIONS

Housing	Fiberglass reinforced thermoplastic
Switching Distance "S"	"On": 4mm (0.16") "Off": 14mm (0.55")
Degree of Protection	IP67
Operating Temperature	-13°F to +158°F
Operating Principle	Magnetic
Shock Resistance	30g/11ms
Vibration Resistance	10 to 55 Hz, amplitude 1mm
Conformity to Standards	CE, UL, CSA VDE 0660 Part 209

*Without ferromagnetic material in vicinity of switch or magnet. The proximity of ferrous material may affect switching distances.

ELECTRICAL SPECIFICATIONS

Maximum Operating Voltage	100VAC/DC 24VDC for -11zG or -12zG versions
Maximum Continuous Current Rating	100 mA (BNS250-11z/12z) 10 mA (BNS250-11zG/12zG)
Maximum Switching Capacity (Power Rating)	1W (BNS250-11z/12z) 240mW (BNS250-11zG/12zG)
Type Connection*	1 meter long LiYY4* 0.25mm ² (23AWG) pre-wired pigtail

*Longer prewired cables (3M, 5M, or 10M lengths) available on request. Please consult factory.

DIMENSIONS

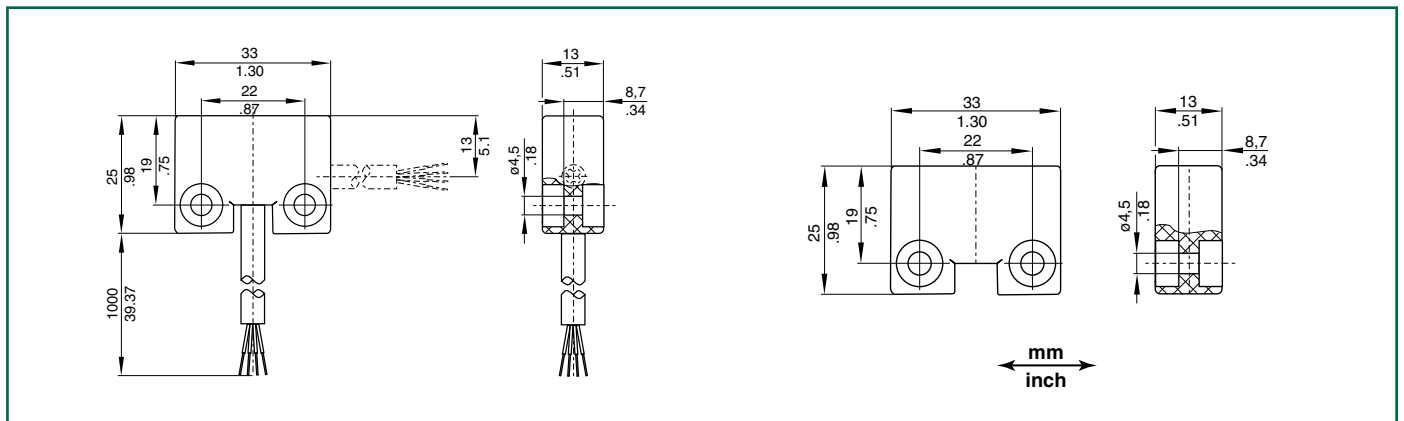

Note: BNS250 reed switch assemblies should be mounted at least 50mm (2") apart.

WIRING DETAILS

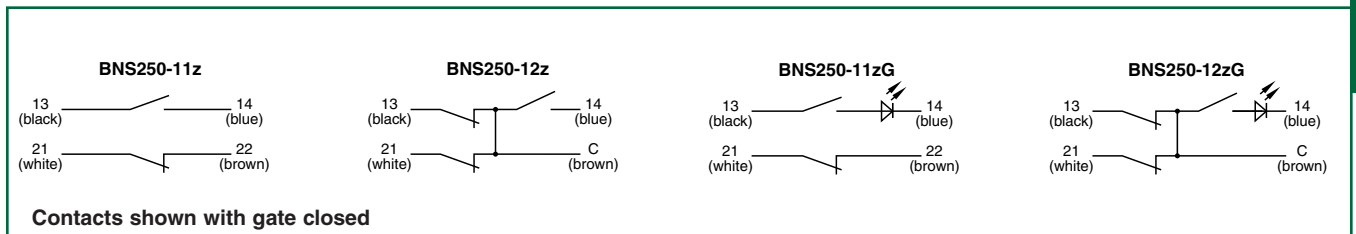

MISALIGNMENT ALLOWANCE

