

SERIES C50

Compact, Safety-Rated, Positive-Break Limit Switches



Features & Benefits

- “Positive-Break” NC contact ... won’t stick or weld shut.
- Compact size ... ideal where space is limited.
- Rugged, corrosion-resistant housing ... tolerates hostile environments.
- Meets rigid safety standards ... IEC, VDE.
- Electrically-insulated contacts ... for added safety.

AVAILABLE STANDARD MODELS

Part Number	Contact Configuration	Actuator Type
C50R	1 NO & 1 NC	Roller plunger
C50ST	1 NO & 1 NC	Adjustable plunger

Description

The C50 Series limit switches are designed for use with movable machine guards/access gates which must be closed for operator safety ... and for any other presence/position sensing application normally addressed with conventional limit switches. Their positive-opening NC contact provides a higher level of safety and reliability than conventional spring-driven limit switches whose contacts can weld or stick shut.

Operation

The C50 Series are designed to mount to a machine structure such that when the guard is open, it directly drives the switch actuator to force open the unit’s positive-break, normally-closed contact. The positive-break NC contact ensures circuit interruption (and machine stoppage). Note that for safety applications, these switches must be mounted in the “positive-mode.”

Typical Applications

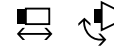

The C50 Series may be used in any presence/position sensing application normally addressed with conventional limit switches.

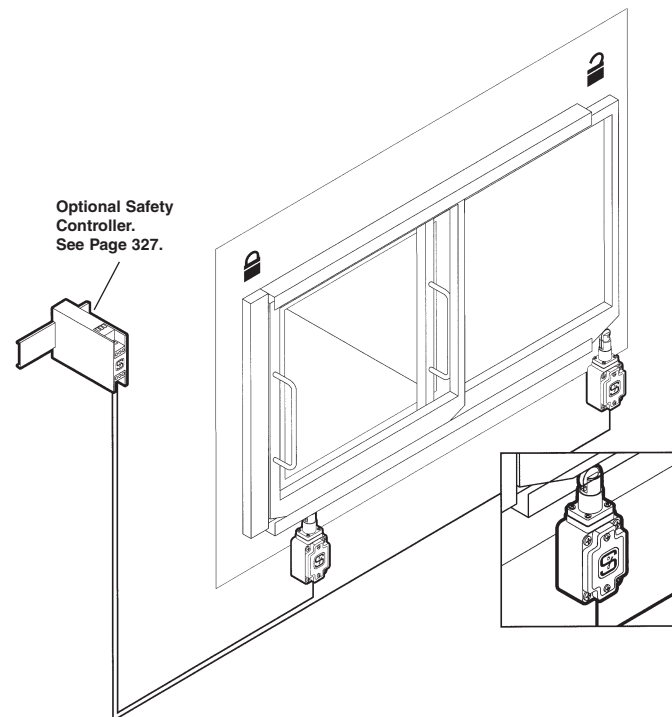

POSITIVE-BREAK is a trademark of SCHMERSAL

SERIES C50 TECHNICAL DATA

MECHANICAL SPECIFICATIONS

Housing	Glass-fiber reinforced (UL94-V0), self-extinguishing thermoplastic
Operating Temperature	-13°F to +167°F
Degree of Protection	IP30
Maximum Operating Rate	1,800 operations/hour
Mechanical Life	>5 million operations
Repeat Accuracy	+/- 0.02 mm
Conformity to Standards	IEC 947-5-1 EN 60947-5-1 DIN VDE 0660 Part 200 EN 60204-1 UL & CSA

ELECTRICAL SPECIFICATIONS

Contacts	Fine silver
Contact Configuration	Double-pole, double-break with electrically-separated bridges
Contact Rating	4A/400VAC (AC-15)
Switching Action	Slow-action, positive-break NC contacts
Electrical Connections	Screw terminals (M3), maximum 13AWG wire
Short Circuit Protection	4A (Slow-blow)

DIMENSIONS & SWITCHING DIAGRAMS

