

## Datasheet - BN 325-R-1279

Magnetic reed switch / BN 325



Preferred typ



(Minor differences between the printed image and the original product may exist!)

- Non-contact principle
- 1 Reed kontakts
- Long life
- Actuating surface and direction of actuation marked by switch symbol
- 85 mm x 26 mm x 24 mm
- Thermoplastic enclosure
- Spade connector
- Cable output left and 2 shielding plates
- Actuation from front

### Ordering details

Product type description	BN 325-R-1279
Article number	101147091
EAN code	4030661141299

### Approval

Approval	-
----------	---

### Global Properties

Product name	BN 325
Standards	IEC/EN 60947-5-2
Compliance with the Directives (Y/N) 	Yes
suitable for elevators (Y/N)	Yes
Mounting	rear with 2 Threaded bolt
Active principle	Magnetic drive
Materials	
- Material of the housings	Plastic, glass-fibre reinforced thermoplastic
Housing construction form	rectangular, flat
Weight	98 g
Recommended actuator	BP 10 N, BP 10 S, 2 x BP 10 N, 2 x BP 10 S, BP 15 N, BP 15 S, 2 x BP 15/2 N, 2 x BP 15/2 S, BP 34 N, BP 34 S, BP 20 N, BP 20 S, BP 31 N, BP 31 S, BP 11 N, BP 11 S, 2 x BP 11 N, 2 x BP 11 S, BP 12 N, BP 12 S, 2 x BP 12 N, 2 x BP 12 S, BP 21 N, BP 21 S, 2 x BP 21 N, 2 x BP 21 S, BE 20, BE 20 N(S) ST 24VDC, BE 20 N(S) 48VDC
- Lift switchgear	BP 10, 2 x BP 10, 2 x BP 15/2, BP 15, BP 34

### Mechanical data

Design of electrical connection	Cable output left and 2 shielding plates
Cable length	1 m
Mechanical life	1.000.000.e+9 operations
Electrical lifetime	1.000.000 ... 1.000.000.e+9 operations
Actuating planes	front side

Switch distance S <sub>n</sub>	5 mm ... 55 mm BP 10N = 10 mm BP 10S = 10 mm 2 x BP 10N = 15 mm 2 x BP 10S = 15 mm BP 15N = 12 mm BP 15S = 12 mm 2 x BP 15/2N = 17 mm 2 x BP 15/2S = 17mm BP 34N = 10 ... 25mm BP 34S = 10 ... 25 mm BP 20N = 5 ... 20 mm BP 20S = 5 ... 20 mm BP 31N = 5 ... 20 mm BP 31S = 5 ... 20 mm BP 11N = 10 mm BP 11S = 10 mm 2 x BP 11N = 20 mm 2 x BP 11S = 20 mm BP 12N = 15 mm BP 12S = 15 mm 2 x BP 12N = 10 ... 25 mm 2 x BP 12S = 10 ... 25 mm BP 21N = 15 ... 40 mm BP 21S = 15 ... 40 mm 2 x BP 21N = 20 ... 55 mm 2 x BP 21S = 20 ... 55 mm BE 20 = 20 mm BE 20N = 15 mm BE 20S = 15 mm
- notice	Actuating distance up to 55 mm depending on actuating magnet and version

The specifications with regard to the switching distances apply to the actuation of the individually mounted devices without ferromagnetic influence. Any change of the distance, positive either negative, is possible due to ferromagnetic interference. When multiple actuating magnets are used, the mutual interference must be observed.

Type of actuation	Magnet
restistance to shock	50 g / 11 ms
Resistance to vibration	10 ... 55 Hz, Amplitude 1 mm
Bounce duration	0,3 ms ... 0,6 ms
Latching (Y/N)	Yes
Actuating speed	max. 18 m/s
Switching point accuracy	± 0,25 mm

## Ambient conditions

---

Ambient temperature	
- Min. environmental temperature	-25 °C
- Max. environmental temperature	+70 °C
Protection class	IP67

## Electrical data

---

Design of control element	bistable contact
Number of snap-in contacts	1
Switching time - Close	max. 1.5 ms
Switching time - Open	max. 0,5 ms
Switch frequency	< 300 Hz
Dielectric strength	> 600 VAC (50 Hz)
Switching voltage	max. 250 VAC

Switching current	max. 3 A
Switching capacity	max. 120 VA

## Outputs

Design of control output	Reed contacts
--------------------------	---------------

## LED switching conditions display

LED switching conditions display (Y/N)	No
--	----

## ATEX

Explosion protection categories for gases	None
Explosion protected category for dusts	None

## Dimensions

Dimensions of the sensor	
- Width of sensor	85 mm
- Height of sensor	26 mm
- Length of sensor	24 mm

## notice

The opening and closing functions depend on the direction of actuation, the actuating magnets and the polarity of the actuating magnets.  
The switch is to be mounted on iron with a non-magnetic layer of at least 20 mm.



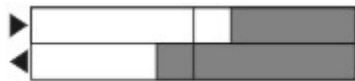

## Included in delivery

Actuators must be ordered separately.

## Switch travel diagram



Notes Switch travel diagram

-  Contact closed
-  Contact open
-  Setting range
-  Break point
-  Positive opening sequence/- angle
- VS** adjustable range of NO contact
- VÖ** adjustable range of NC contact
- N** after travel

## Documents

**Mounting and wiring instructions** (de, en, fr) 61 kB, 13.06.2008

Code: m\_n30p01

**Declaration of conformity** (de) 188 kB, 10.07.2012

Code: \_\_bn\_p01

**notice - Switch distance** (pt) 39 kB, 07.08.2009

Code: s\_bnbsp10

**notice - Switch distance** (es) 38 kB, 07.08.2009

Code: s\_bnbsp09

**notice - Switch distance** (it) 40 kB, 07.08.2009

Code: s\_bnbsp05

**notice - Switch distance** (nl) 39 kB, 07.08.2009

Code: s\_bnbsp04

**notice - Switch distance** (fr) 41 kB, 07.08.2009

Code: s\_bnbsp03

**notice - Switch distance** (en) 42 kB, 07.08.2009

Code: s\_bnbsp02

**notice - Switch distance** (de) 36 kB, 07.08.2009

Code: s\_bnbsp01

## Images

---

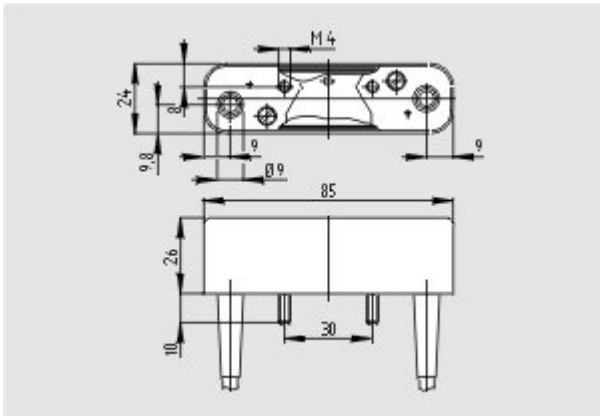

Dimensional drawing (basic component)

---

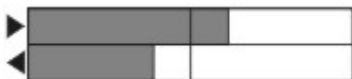

Switch travel diagram

---

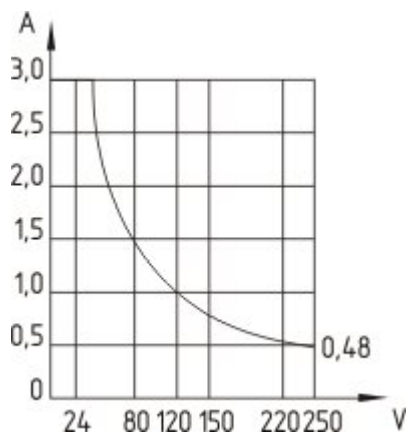

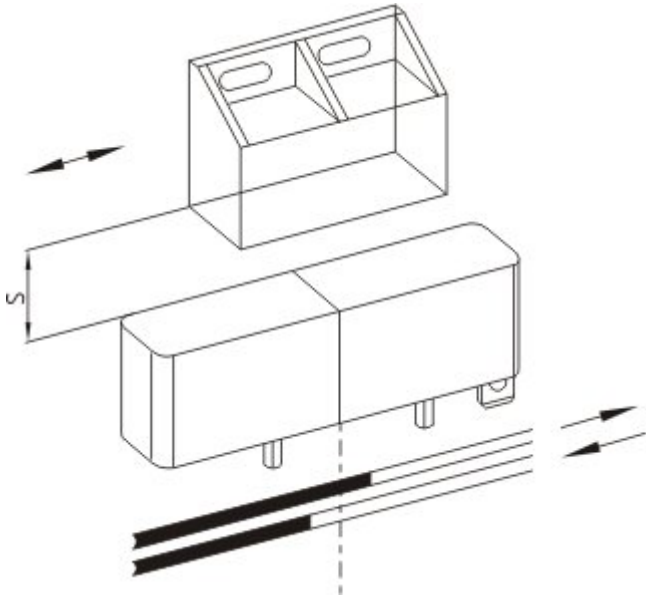

Diagram

---

K.A. Schmersal GmbH & Co. KG, Möddinghofe 30, D-42279 Wuppertal

The data and values have been checked thoroughly. Technical modifications and errors excepted.

Generiert am 12.02.2013 - 15:15:29h Kasbase 2.2.2.F DBI

Image

Image  
et=sS