

5. Magnetic reed switches



Application Non-contact functioning limit switches are mainly used where mechanically actuated limit switches no longer function satisfactorily due to unfavourable operating conditions such as high or low start-up speeds, high switching frequency, a strong dust or dirt influence, high humidity, a chemical atmosphere, or large fluctuations in operation intervals. In the elevator industry, the magnetic reed switches are preferably used for positioning and control.

One type of the non-contact functioning limit switches are the magnetic reed switches. Further types are the inductive, capacitive, and optical proximity switches, see to catalogue part 2. However, in order to be able to make the right selection, it is necessary to know the general design and function of magnetic reed switches.

Design and function

The magnetic reed switches in the BN 325, BN 65, BN 8 series consist of two units, the switch and the actuating magnet. The reed contacts of our magnetic switches are filled with nitrogen. The contacts, made of an iron/nickel alloy, are melted into the glass structure and are coated with rhodium in the area of the contact points. The air gap between the contacts amounts to only 0.2 to 0.3 mm, so that the magnetic force necessary for the switching process remains very low. The contacts are protected from dust, humidity and corrosion through the enclosed glass tube. Magnetic reed switches thus have an extraordinarily high contact reliability. The contact type is determined by installation and exact measurement of the bias magnets:

NO contact

NC contact

changeover contact

bistable contact

bistable changeover contact

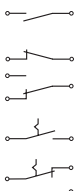

5. Magnetic reed switches

In addition, the bias magnets are adjusted so that the exact centre position of the switch points is guaranteed.

This adjustment is always made in the same interval with a test magnet, specifically chosen for this purpose, so that the exchangeability of equivalent switching elements is guaranteed. After the adjustment has been completed, the reed contact and bias magnet are fixed together with glue and then cast with an elastic filling material. For actuating the switch, permanent magnets with and without an enclosure as well as an electromagnet are used. Depending on the switch type, a specific actuating magnet must be selected for lateral actuation. For NC, NO and changeover contacts, an actuating magnet with N-S pole; for bistable and bistable changeover contacts, an actuating magnet with N or S pole is selected. The utilised magnet material, barium ferrite, is non-ageing and hardly loses its magnetism through other magnetic fields. Still, its temperature dependence of 0.2 % per degree °C must be taken into consideration concerning the switch point accuracy. The magnetic force decreases with increasing temperatures by this factor and increases by decreasing temperatures. However, a permanent change is the range of - 30 °C to + 90 °C is not to be expected.

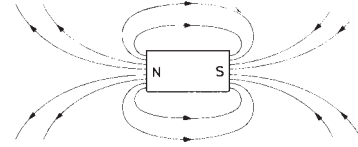

magnetic field N-S magnet

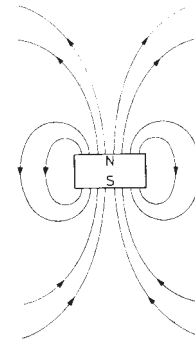

magnetic field N- or S-magnet

Notice

When electrical wires are laid parallel to the switch, a minimum distance of 50 mm must be maintained. In the very frequent occurring arrangement of units next to one another, it must be made certain that sufficient distance is maintained. Depending on the size of the actuating magnets, unwanted actuation of the adjacent switch could occur. An effective remedy is achieved by shielding plates, located between the switches. In this case it must be noted that the iron shield absorbs a portion of the magnetic field lines and the maximum actuating distance is decreased.

Contact welding can occur when using longer cables. Due to the very different cable capacities caused by the cable design and cross-section, no exact information can be given. In fact, welding can occur from 25 m cable lengths through very short periods of capacitive charges. In order to avoid such welding, bucking coils have been developed for different lengths, see chapter 5.8. These bucking coils are wired in series with the reed contacts.

Technical data for the magnetic switches listed above are shown in tabular form in chapter 5.9.

5. Magnetic reed switches
5.1 BN 85-5 Series



Features

- thermoplastic enclosure
- bistable contact
- long lifetime
- non-contacting
- for triggering of relays
- 5 reed-contacts to clip-on
- reciprocal switch function through rotating the individual switching elements by 180°
- LED for indicating the switch status
- unused plugs can be filled with blank elements
- with 10-pole plug-in connection
- IP 30 protection class

Scope of supplies

- unit without switch inserts
- 2 blank inserts

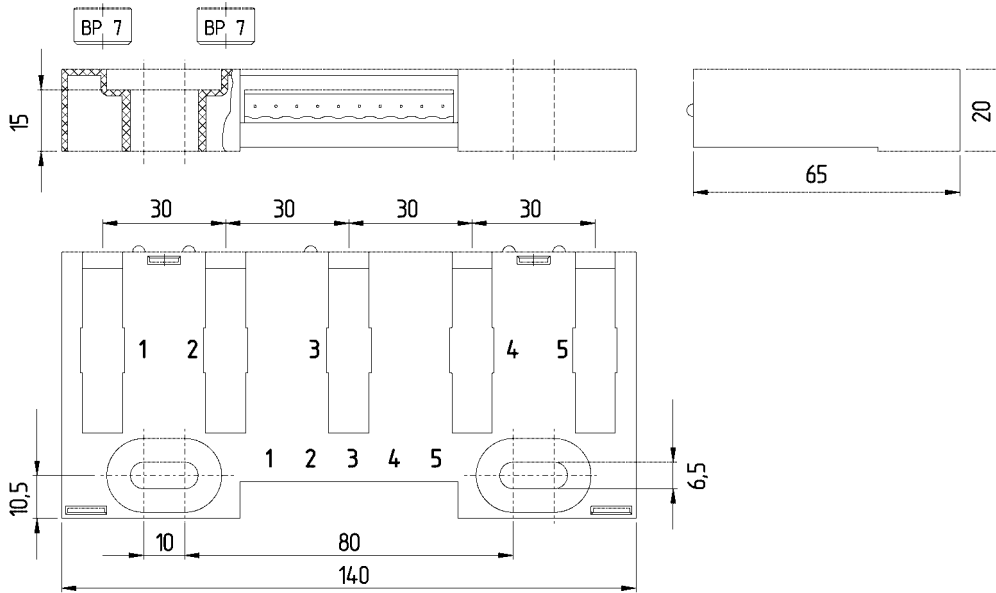

Info • for connection of control units, order index -2031

Notice **The actuating magnet BP 7 is not included in the scope of supplies of the switch, see chapter 5.7.**

Appropriate switch inserts, part number BN 85-re.

Latching function The NC and NO function is dependent on the direction of actuation, the strength and polarity of the actuating magnet.

5. Magnetic reed switches
5.1 BN 85-5 Series

Actuating distances

actuating magnet:	BP 7
with mounting on ferromagnetic material	
average max. actuating distance s:	14 mm
max. actuating distance under unfavourable conditions s_{max} :	11 mm
min. actuating distance s_{min} :	1 mm
effective actuating distance s_{nenn} :	6 mm
with mounting on non-ferrous material (e.g. plastic rail)	
actuating distance s:	0 ... 9 mm
effective actuating distance s_{nenn} :	5 mm

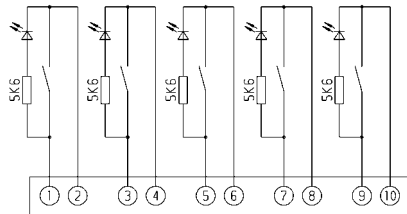

1 bistable contact

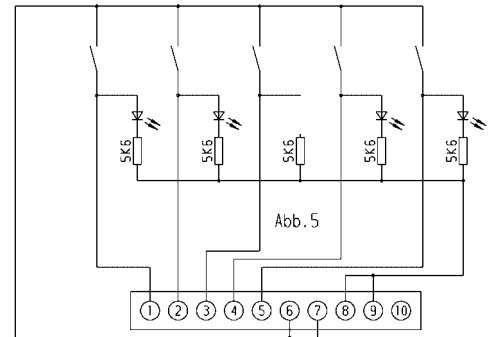

1 bistable contact

Contacts

for triggering of relays **BN 85-5**
 for connection to control units

BN 85-5-2031

Direction of actuation

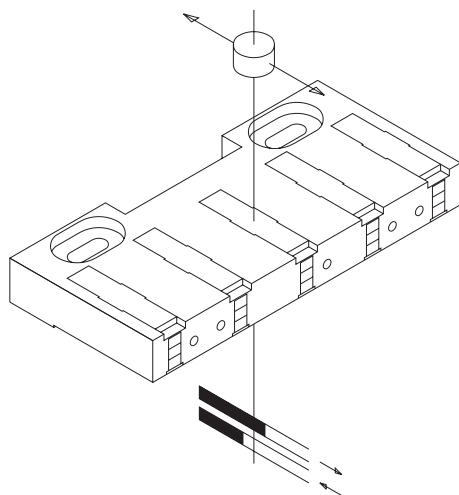

5. Magnetic reed switches

5.2 BN 85 Series

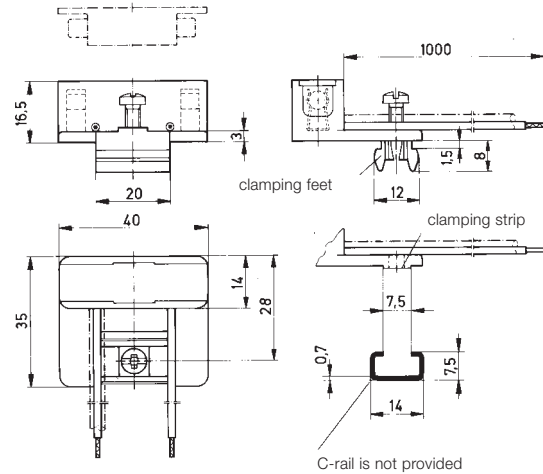
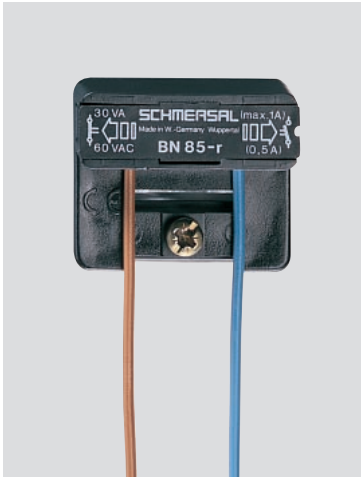

Features

- thermoplastic enclosure
- long lifetime
- bistable contact
- non-contact functioning
- mounting with clamping feet and screw clamp
- reed-contact to clip-in, on-location assembly
- adjustment by loosening the central mounting screw
- actuating distance up to 40 mm, depending on actuating magnet
- with pre-wired cable, cable length 1 m
- two individual wires LiYY 0.75 mm²
- IP 40 protection class

Info

- for mounting on C-rail, two individual wires LiYY 0.75 mm², M4 sliding nuts without screw, ordering suffix -1831-1
- for mounting on C-rail, two individual wires LiYY 0.75 mm², M4 sliding nuts with screw, ordering suffix -1831-2
- for mounting on C-rail, non-metallic sheathed cable LiYY 2 x 0.25 mm², M4 sliding nuts without screw, ordering suffix -1824-1
- for mounting on C-rail, non-metallic sheathed cable LiYY 2 x 0.25 mm², M4 sliding nuts with screw, ordering suffix -1824-2
- with clamping feet and screw, non-metallic sheathed cable LiYY 2 x 0.25 mm², order index -1824-3

BN  BU

Contacts

1 bistable contact

standard

BN 85-r

Notice

The actuating magnets are not included in the scope of supplies of the switch. For the selection, see chapter 5.7.

Latching function

The NC and NO function is dependent on the direction of actuation, the strength and polarity of the actuating magnet.

5. Magnetic reed switches
5.2 BN 85 Series

Actuating magnets

part number	BN 85-rz
switch travel	
contacts	1 bistable contact
actuation type	N or S

actuating magnet	actuating distance [mm]
BP 6 N	2-12
BP 6 S	2-12
BP 7 N	0-9
BP 7 S	0-9
BP 8 N	2-10
BP 8 S	2-10
BP 10 N	5-20
BP 10 S	5-20
BP 2 x 10 N	6-27
BP 2 x 10 S	6-27
BP 11 N	4-23
BP 11 S	4-23
BP 12 N	5-27
BP 12 S	5-27
BP 15 N	5-22
BP 15 S	5-22
BP 15/2 N	7-30
BP 15/2 S	7-30
BP 2 x 15 N	7-28
BP 2 x 15 S	7-28
BP 20 N	3-28
BP 20 S	3-28
BP 31 N	4-30
BP 31 S	4-30
BP 34 N	10-40
BP 34 S	10-40

Direction of actuation

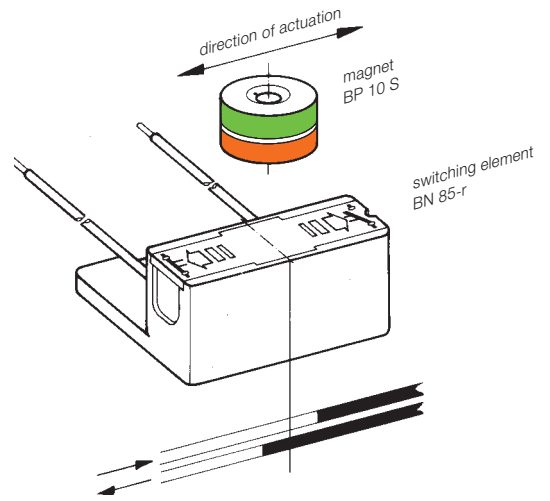

Switching ability

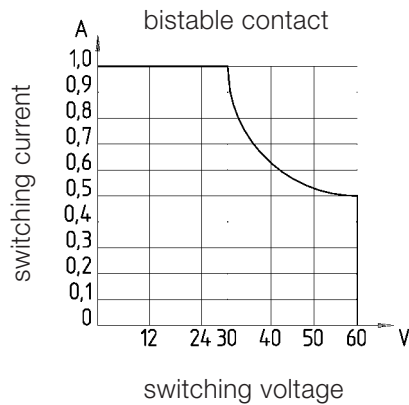

5. Magnetic reed switches
5.3 BN 80 Series

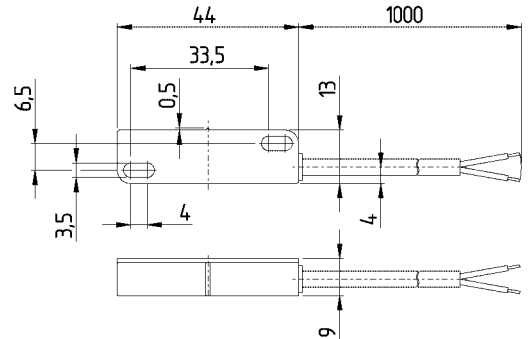

Features

- thermoplastic enclosure
- flat design
- bistable contact
- long lifetime
- non-contact functioning
- 1 reed contact
- actuating distance up to 60 mm, depending on actuating magnet
- actuating surface marked by protrusion
- with pre-wired cable, cable length 1 m
- IP 67 protection class

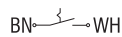

Contacts

1 bistable contact

standard

BN 80-rz

Notice

The actuating magnets are not included in the scope of supplies of the switch. For the selection, see chapter 5.7.

Latching function

The NC and NO function is dependent on the direction of actuation, the strength and polarity of the actuating magnet.

5. Magnetic reed switches
5.3 BN 80 Series

Actuating magnets

part number	BN 80-rz
switch travel	
contacts	1 bistable contact
actuation type	S

actuating magnet	actuating distance [mm]
BP 6 S	4-18
BP 7 S	6-22
BP 10 S	10-30
BP 2 x 10 S	12-36
BP 11 S	10-30
BP 12 S	10-34
BP 15 S	12-30
BP 2 x 15 S	13-38
BP 20 S	10-38
BP 31 S	12-40
BP 34 S	20-50
BP 2 x 34 S	22-60

Direction of actuation

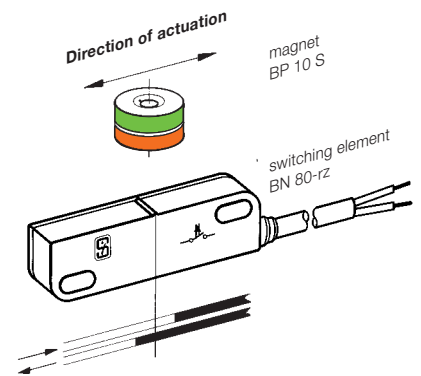

Switching ability

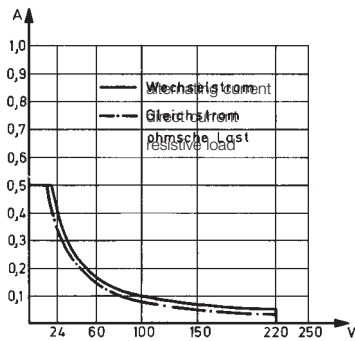

5. Magnetic reed switches

5.4 BN 310 Series

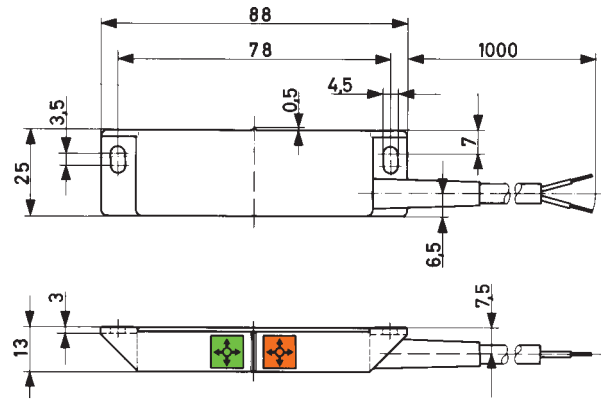

Features

- thermoplastic enclosure
- flat design
- NC, NO or bistable contacts
- long lifetime
- non-contact functioning
- 1 reed contact
- actuating surface and direction of actuation marked by switch symbol
- with pre-wired cable, cable length 1 m
- IP 67 protection class

Contacts

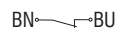

1 NC contact



1 NO contact



1 bistable contact

standard

BN 310-01z

BN 310-10z

BN 310-rz

Notice

The actuating magnets are not included in the scope of supplies of the switch. For the selection, see chapter 5.7.

When the switch and actuating magnet face each other, the colours must be corresponding: red (S) to red (S) and green (N) to green (N). This does not apply to the bistable contact.

The switch is to be mounted on iron with a non-magnetic layer of at least 20 mm.

Switching ability

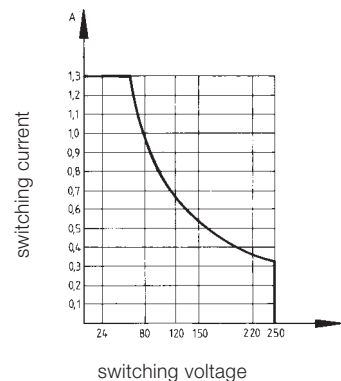

Latching function

The NC and NO function is dependent on the direction of actuation, the strength and polarity of the actuating magnet.

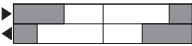

5. Magnetic reed switches
5.4 BN 310 Series

Actuating magnets

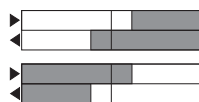
part number	BN 310-01z	BN 310-10z	BN 310-rz
switch travel			
contacts	1 NC contact	1 NO contact	1 bistable contact
actuation type	S or N	S or N	N/S

actuating magnet	actuating distance [mm]			
BE 20	20			
BE 20 N	20			
BE 20 S	20			
BP 10	5			
BP 10 N	15			
BP 10 S	15			
BP 2x 10	15			
BP 2x 10 N	20			
BP 2x 10 S	20			
BP 11	8-20			
BP 11 N	15			
BP 11 S	15			
BP 2x 11 N	3-25			
BP 2x 11 S	3-25			
BP 12	10-30			
BP 12 N	20			
BP 12 S	20			
BP 15	6			
BP 15 N	17			
BP 15 S	17			
BP 2x 15/2	17			
BP 2x 15/2 N	22			
BP 2x 15/2 S	22			
BP 20	20			
BP 20 N	3-25			
BP 20 S	3-25			
BP 21	25-50			
BP 21 N	15-45			
BP 21 S	15-45			
BP 2x 21 N	20-60			
BP 2x 21 S	20-60			
BP 31	20			
BP 31 N	3-25			
BP 31 S	3-25			
BP 34	5-20			
BP 34 N	15-30			
BP 34 S	15-30			

 = suitable
 = unsuitable

5. Magnetic reed switches

5.5 BN 325 Series

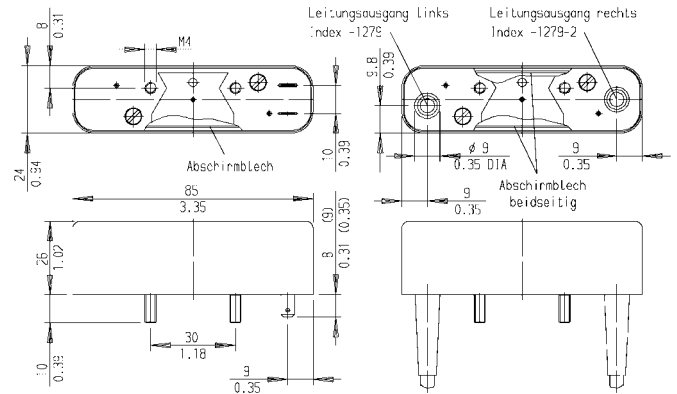

Features

- thermoplastic enclosure
- bistable contact
- long lifetime
- non-contact functioning
- 1 reed contact
- surface and direction of actuation marked by switch symbol
- mounting with two threaded bolts
- spade connector 4.8 mm
- with pre-wired cable, cable length 1m
- IP 40 protection class

Info

- available with LED, ordering suffix G 24
- spade connector 4.8 mm and 1 additional shielding plate, ordering suffix -1239
- spade connector 6.3 mm and 1 additional shielding plate, ordering suffix -1389
- cable outlet left and 1 additional shielding plate, ordering suffix -1279
- cable outlet right and 1 additional shielding plate, ordering suffix -1279-2

BN  BU

Contacts

1 bistable contact

standard

BN 325-r

Notice

The actuating magnets are not included in the scope of supplies of the switch. For the selection, see chapter 5.7.

The dimensions and connection dimensions are identical with BN 32.

Switching ability

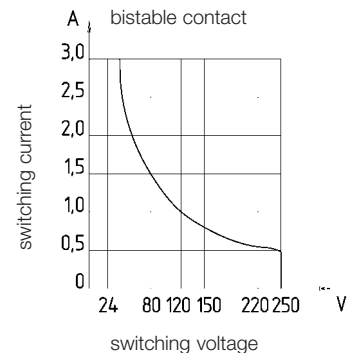

Latching function

The NC and NO function is dependent on the direction of actuation, the strength and polarity of the actuating magnet.

5. Magnetic reed switches

5.5 BN 325 Series

Actuating magnets

part number	BN 325-r
switch travel	
contacts	1 bistable contact
actuation type	N/S

actuating magnet	actuating distance [mm]
BE 20 N	15
BE 20 S	15
BP 10 N	10
BP 10 S	10
BP 2x 10 N	15
BP 2x 10 S	15
BP 11 N	10
BP 11 S	10
BP 2x 11 N	20
BP 2x 11 S	20
BP 12 N	15
BP 12 S	15
BP 15 N	12
BP 15 S	12
BP 2x 15/2 N	17
BP 2x 15/2 S	17
BP 20 N	5-20
BP 20 S	5-20
BP 21 N	15-40
BP 21 S	15-40
BP 2x 21 N	20-55
BP 2x 21 S	20-55
BP 31 N	5-20
BP 31 S	5-20
BP 34 N	10-25
BP 34 S	10-25

Assembly directions

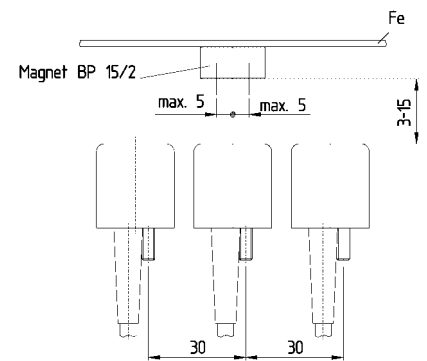
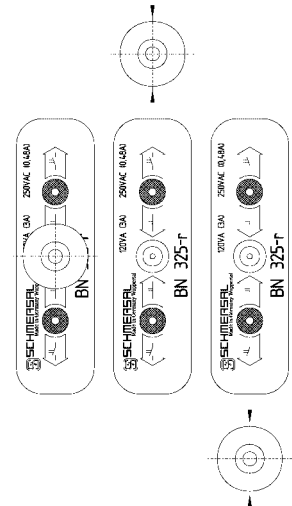

- max. actuating distance with misalignment of the actuating magnet
- from -20 °C ... + 50 °C

Direction of actuation

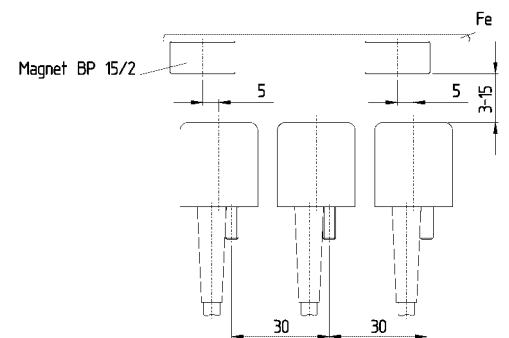
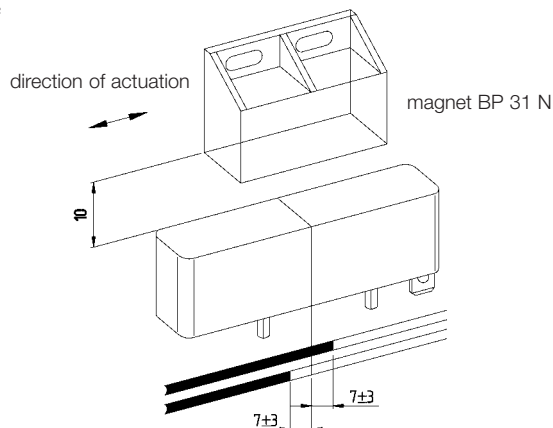

- max. misalignment of two magnets without affecting the centre switch

5. Magnetic reed switches

5.6 BN 65 and BN 65/V Series

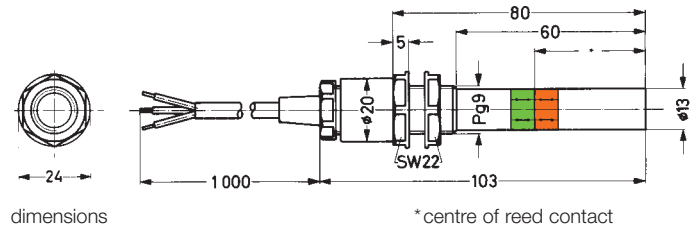
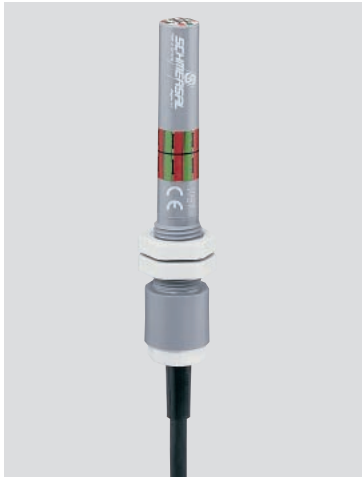

Features

- thermoplastic enclosure
- central mounting
- NC , NO , bistable, changeover or bistable changeover contacts
- long lifetime
- non-contact functioning
- lateral and front actuation
- surface and direction of actuation marked by switch symbol
- moulded cable, cable length 1 m
- IP 67 protection class

Info

- can be mounted with bracket H 1/1 or H 2 on iron, for brackets see chapter 5.8

Contacts

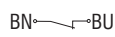

1 NC contact

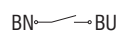

1 NO contact

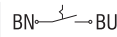

1 bistable contact

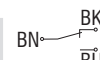

1 changeover contact

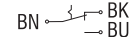

1 bistable changeover contact

lateral actuation
front
actuation
front actuation
without
bias magnet

BN 65-01z

BN 65-10z

BN 65-rz

BN 65-11z

BN 65-11rz

BN 65-01z/V

BN 65-10z/V

BN 65-rz/V

BN 65-11z/V

BN 65-11rz/V

BN 65-11z/1V

Notice

The actuating magnets are not included in the scope of supplies of the switch. For the selection, see chapter 5.7.

When the switch and actuating magnet face each other, the colours must be corresponding: red (S) to red (S) and green (N) to green (N). This does not apply to the bistable contact.

Switching ability

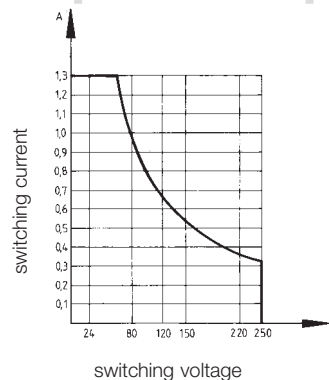

Latching function

The NC and NO function is dependent on the direction of actuation, the strength and polarity of the actuating magnet.

5. Magnetic reed switches
5.6 BN 65 and BN 65/V Series

Actuating magnets for lateral actuation

part number	BN 65-01z	BN 65-10z	BN 65-rz
switch travel			
contacts	1 NC contact	1 NO contact	1 bistable contact
actuation type	S or N	S or N	N/S

actuating magnet	actuating distance [mm]			
BE 20	20			
BE 20 N	20			
BE 20 S	20			
BP 10	5			
BP 10 N	15			
BP 10 S	15			
BP 2x 10	15			
BP 2x 10 N	20			
BP 2x 10 S	20			
BP 11	20			
BP 11 N	15			
BP 11 S	15			
BP 2x 11 N	25			
BP 2x 11 S	25			
BP 12	10-30			
BP 12 N	20			
BP 12 S	20			
BP 15	6			
BP 15 N	17			
BP 15 S	17			
BP 2x 15/2	17			
BP 2x 15/2 N	22			
BP 2x 15/2 S	22			
BP 20	20			
BP 20 N	25			
BP 20 S	25			
BP 21	25-50			
BP 21 N	15-45			
BP 21 S	15-45			
BP 2x 21 N	20-60			
BP 2x 21 S	20-60			
BP 31	20			
BP 31 N	25			
BP 31 S	25			
BP 34	15-20			
BP 34 N	15-30			
BP 34 S	15-30			

= suitable
 = unsuitable

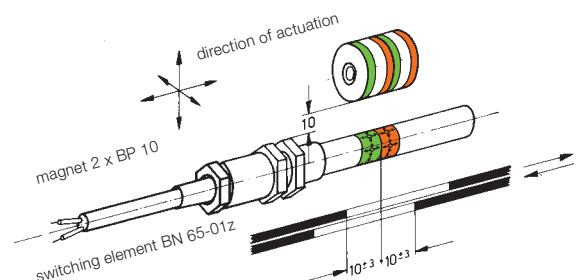

5. Magnetic reed switches
5.6 BN 65 and BN 65/V Series

Actuating magnets for front actuation

part number	BN 65-01z/V BN 65-10z/V	BN 65-rz/V	BN 65-11z/V BN 65-11z/1V	BN 65-11rz/V
switch travel				
contacts	1 NC contact 1 NO contact	1 bistable contact N-actuated 1 bistable contact S-actuated	1 changeover contact	1 bistable change-over contact
actuating type	S or N	N/S	S or N	N/S

actuating magnet	actuating distance [mm]	BN 65-01z/V	BN 65-10z/V	BN 65-rz/V	BN 65-11z/V	BN 65-11z/1V	BN 65-11rz/V
BE 20	10						
BE 20 S	6						
BP 10	3						
BP 10 S	5						
BP 2x 10 S	10						
BP 11	15						
BP 11 S	5						
BP 2x 11 S	15						
BP 12	20						
BP 12 S	10						
BP 2x 12 S	25						
BP 15 S	6						
BP 20	10						
BP 20 S	15						
BP 21	45						
BP 21 S	30						
BP 2x 21 S	20-55						
BP 22 S	25						
BP 22 N+S	35						
BP 22/1 S	15						
BP 22/1 N+S	25						
BP 2x 22 S	15-55						
BP 2x 22/1 S	35						
BP 31	10						
BP 31 S	15						
BP 34	15						
BP 34 S	20						

= suitable
 = unsuitable

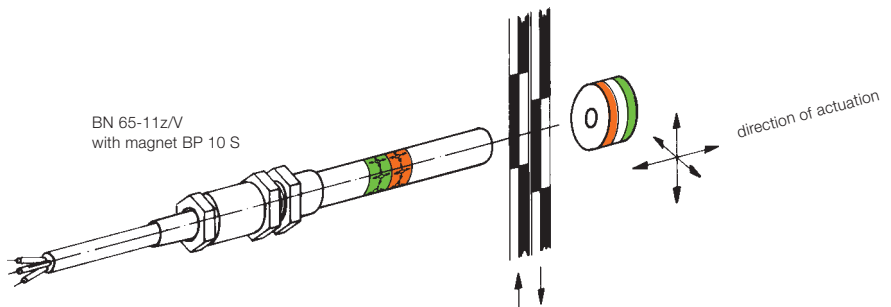

5. Magnetic reed switches
5.7 Actuating magnets – permanent magnets

BP 6

- non-encapsulated
- S-pole marked by red dot

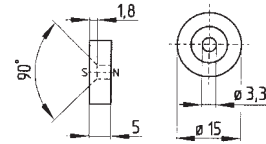

BP 7

- non-encapsulated
- S-pole marked by red dot

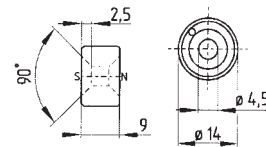

BP 8

- non-encapsulated
- S-pole marked by red dot
- can be mounted on iron with 10 mm distance

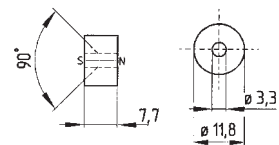

5. Magnetic reed switches
5.7 Actuating magnets – permanent magnets

BP 10

- non-encapsulated
- coloured markings of the poles with adhesive film
- can be mounted on iron with 15 mm distance

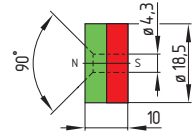

BP 15 and BP 15/2

- BP 15/2**
- non-encapsulated
 - pressed in polarity
 - can be mounted on iron with 18 mm distance

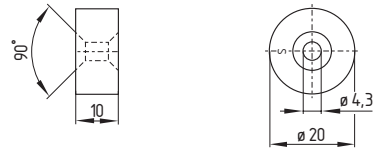

- BP 15**
- plastic encapsulated
 - can be mounted on iron with 18 mm distance



BP 34

- plastic encapsulated
- can be mounted on iron with 25 mm distance

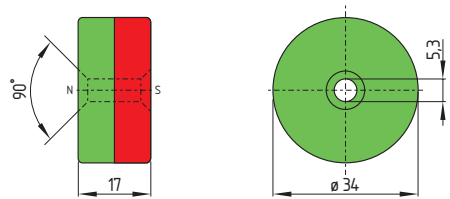

5. Magnetic reed switches
5.7 Actuating magnets – permanent magnets

BP 20

- metal encapsulated, Al-enclosure
- can be mounted on iron with 20 mm distance

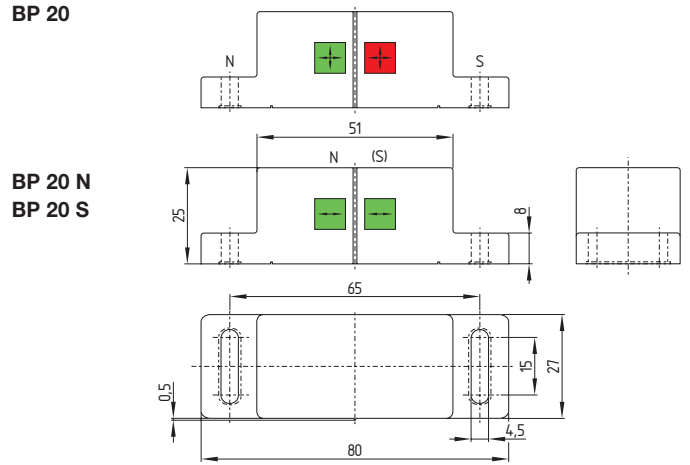

BP 31

- plastic encapsulated
- can be mounted on iron with 20 mm distance

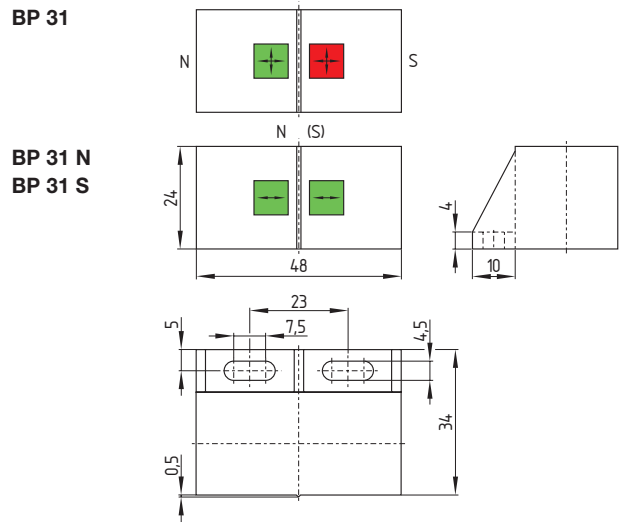

BP 11

- metal encapsulated, Al-enclosure
- can be mounted on iron

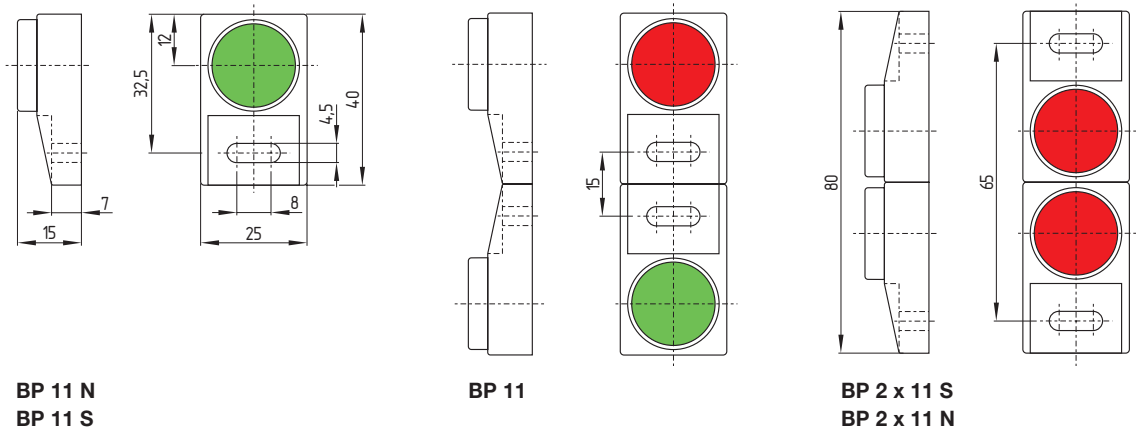

5. Magnetic reed switches
5.7 Actuating magnets – permanent magnets

BP 12

- metal encapsulated, Al-enclosure
- can be mounted on iron

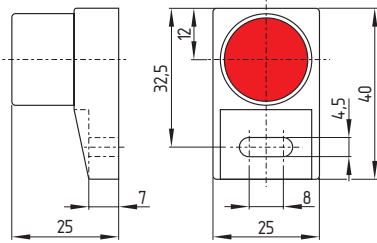

BP 12 N
BP 12 S

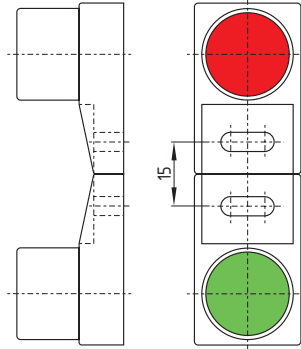

BP 12

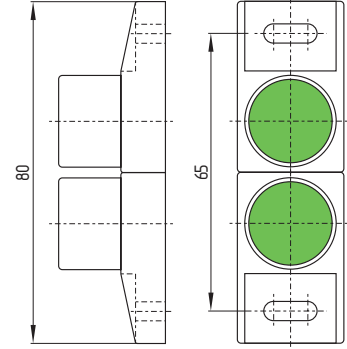

BP 2 x 12 S
BP 2 x 12 N

BP 21

- metal encapsulated, Al-enclosure
- can be mounted on iron

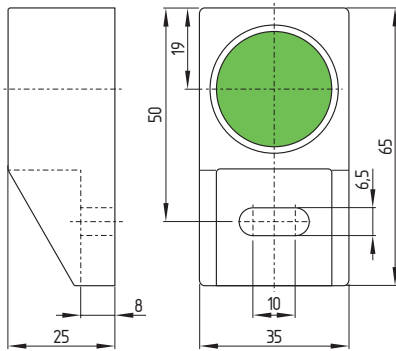

BP 21 N
BP 21 S

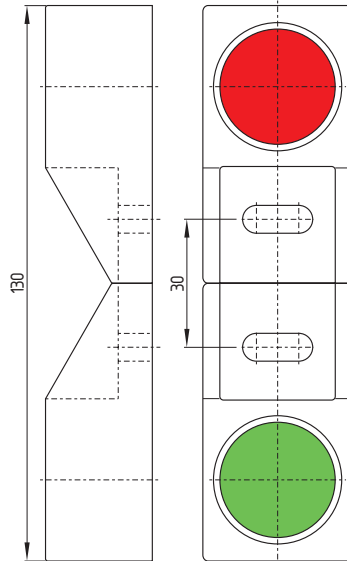

BP 21

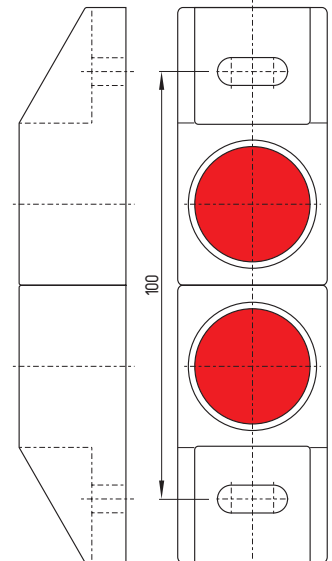

BP 2 x 21 S
BP 2 x 21 N

5. Magnetic reed switches
5.7 Actuating magnets – permanent magnets

BP 22

- metal encapsulated, Zn-enclosure
- usable as N- or S-magnet
- can be mounted on iron

BP 22
BP 22/1
BP 22/2

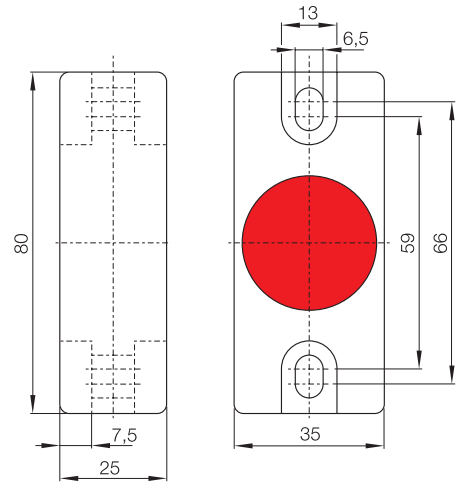

BP 22 N and BP 22 S
BP 22/1 N and BP 22/1 S
BP 22/2 N and BP 22/2 S

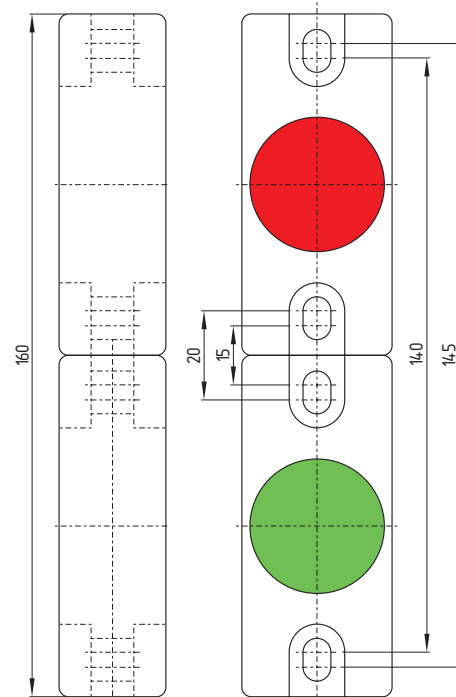

BP 2 x 22 N
BP 2 x 22 S
BP 2 x 22/1 N
BP 2 x 22/1 S
BP 2 x 22/2 N
BP 2 x 22/2 S

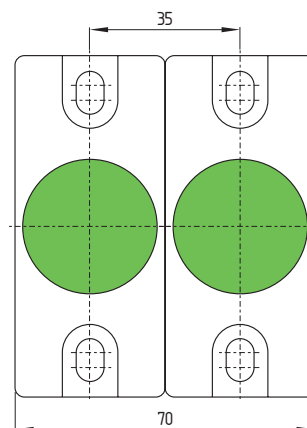

5. Magnetic reed switches

5.7 Actuating magnets – electromagnets

BE 20

- thermoplastic enclosure
- cast coil
- with BE 20 and BE 20 N, brown (BN) connection to positive pole (+)
- with BE 20 S, brown (BN) connection to negative pole (-)
- connection cable H03VV-F 2x 0.75 mm², cable length 1 m
- IP 67
- voltage: 24 VDC, 48 VDC, 60 VDC or 110 VDC
- 6 W power consumption
- 100% ED operating time
- ambient temperature: - 25 °C ... + 75 °C
- BE 20: can be mounted on iron with 25 mm distance
- BE 20 N (S): can be mounted on iron

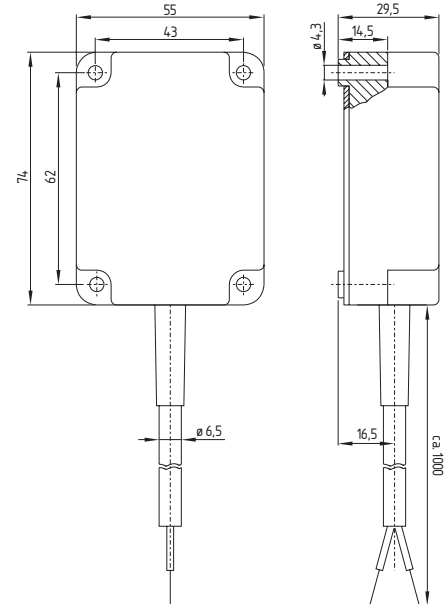

BE 20 ST

- thermoplastic enclosure
- cast coil
- plug with soldered connection for max. 1.5 mm² connection
- IP 67
- with BE 20 ST and BE 20 N ST, connection from Pin 2 to positive pole (+)
- with BE 20 S ST, connection from Pin 2 to negative pole (-)
- voltage: 24 VDC, 48 VDC, 60 VDC or 110 VDC
- 6 W power consumption
- 100% ED operating time
- ambient temperature: - 25 °C ... + 75 °C
- BE 20: can be mounted on iron with 25 mm distance
- BE 20 N (S): can be mounted on iron

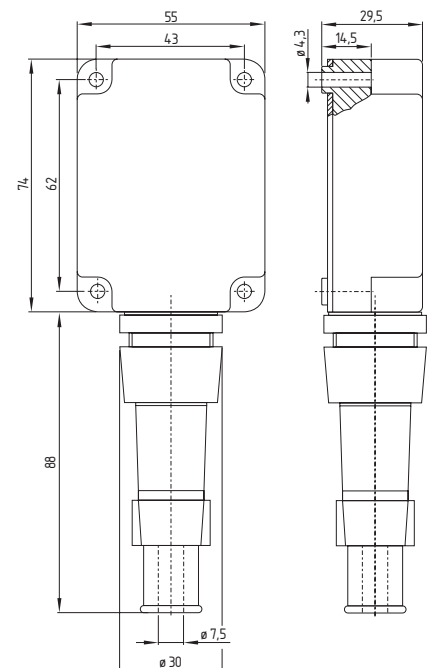

5. Magnetic reed switches
5.8 Accessories

Type H 1/1 bracket

- for BN 65
- metal bracket with 2 elastic bearing blocks
- guarantees high vibration resistance

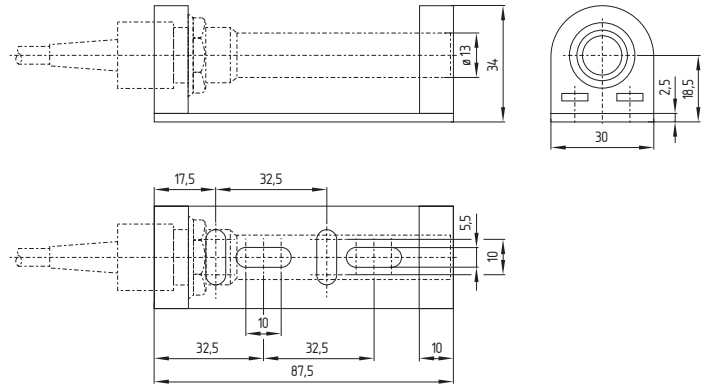

Type H 2 bracket

- for BN 65
- metal bracket with rubber plates

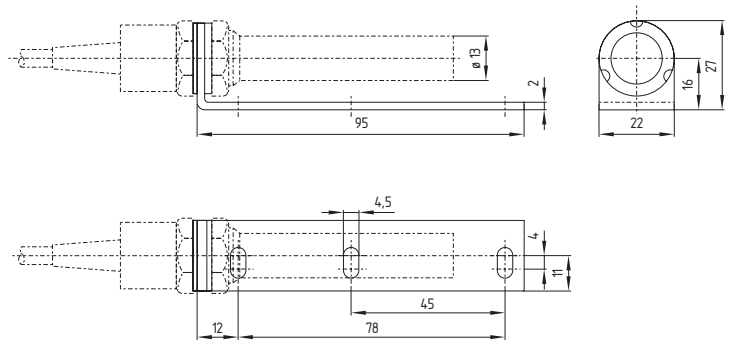

H 15 clamp

- for BN 65

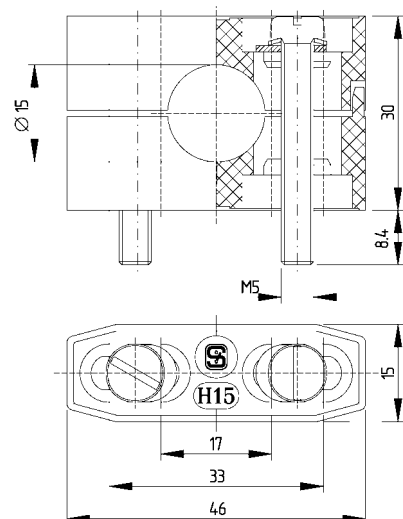

5. Magnetic reed switches
5.8 Accessories

KS 1 bucking coil

- dimension X = 23 mm
- for cable lengths up to 100 m
- H07V-K connection cable 1 mm², cable length 1 m

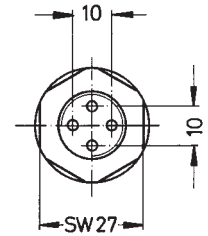
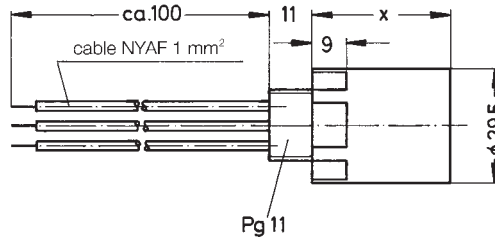

Notice

- the bucking coil is to be wired in series with the reed contact

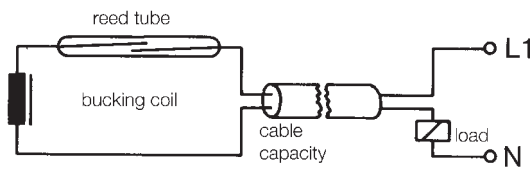

KS 2 bucking coil

- dimension X = 36 mm
- for cable lengths up to 200 m or 2 x 100 m

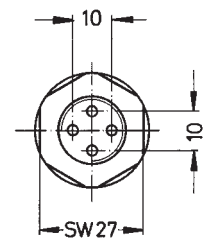
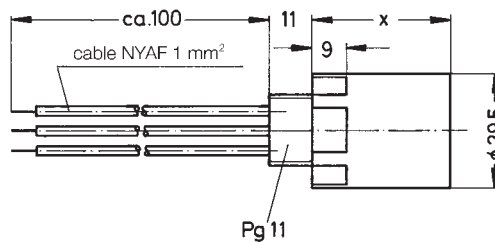

Notice

- the bucking coil is to be wired in series with the reed contact

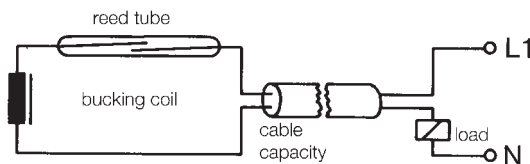

5. Magnetic reed switches

5.9 Technical data

	BN 85-5	BN 85	BN 80
Standards:	DIN VDE 0660-209		
Design:	square		
Enclosure:	fibreglass reinforced thermoplastic		
Protection class:	IP 30	IP 40	IP 67
	per IEC / EN 60529 / DIN VDE 0470-1		
Termination:	10-pole plug-in connector	2 individual wires LiY 0.75 mm ² , cable length 1 m	2 individual wires LiYY 0.25 mm ² , cable length 1 m
Operating principle:	magnetic		
Switch status indicator:	LED; switch open, -2031: switch closed	–	
Actuating magnet:	BP 7	see chapter 5.2	see chapter 5.3
Switching voltage:	12 ... 60 VDC	max. 60 VAC/DC	max. 250 VAC/DC
Switching current:	max. 1 A		max. 0.5 A
Switching capacity:	max. 30 W	max. 30 VA/W	max. 10 VA, 8 W
Dielectric strength:	400 VDC		> 450 VAC
Switching speed:	–		
Switching frequency:	max. 300/s with BN 310-01z,-10z		
Switching time "closing":	2 ms		
Switching time "opening":	0.07 ms		
Bounce time:	–	max. 0.2 ms	max. 0.5 ms
Ambient temperature:	– 10 °C ... + 75 °C	0 °C ... + 75 °C	– 25 °C ... + 75 °C
Mechanical life:	min. 10 ⁹		
Electrical life:	5 x 10 ⁸ , depending on load		5 x 10 ⁶ , depending on load
Shock resistance:	60 g, sinusoidal oscillation		15 g, sinusoidal oscillation
Vibration resistance:			
Repeatability:			



5. Magnetic reed switches

5.9 Technical data

	BN 310	BN 325	BN 65 BN 65/V
Standards:	DIN VDE 0660-209		
Design:	square		cylindrical
Enclosure:	fibreglass reinforced thermoplastic		
Protection class:	IP 67	IP 00, IP 40 mounted with insulated plug	IP 67
	per IEC/EN 60529/DIN VDE 0470-1		
Termination:	H03VV-F2 x 0.75 mm ² , cable length 1 m	spade connector 4.8 mm	H03VV-F2 x 0.75 mm ² , A03VV-F3 x 0.75 mm ² , cable length 1 m
Operating principle:	magnetic		
Switch status indicator:	-		
Actuating magnet:	see chapter 5.4	see chapter 5.5	see chapter 5.6
Switching voltage:	max. 250 VAC/DC	max. 250 VAC	max. 250 VAC; BN 65-rz/V, -11rz/V: max. 220 VAC, 150 VDC
Switching current:	max. 3 A		max. 3A; BN 65-rz/V,-11rz/V: max. 1 A
Switching capacity:	max. 120 VA/W	max. 120 VA	max. 120 VA; BN 65-rz/V, -11rz/V: max. 80 VA/W
Dielectric strength:	> 600 VAC		> 600 VAC; BN 65-rz/V, -11rz/V: >350 VAC
Switching speed:	max. 18 m/s		
Switching frequency:	max. 300/s with BN 310-01z,-10z	max. 300/s	
Switching time "closing":	0.3 ... 1.5 ms	max. 1.5 ms	0.3 ... 1.5 ms
Switching time "opening":	max. 0.5 ms		
Bounce time:	0.3 ... 0.6 ms		0.3 ... 0.6 ms, max. 3 ms
Ambient temperature:	- 25 °C ... + 75 °C		
Mechanical life:	min. 10 ⁹		
Electrical life:	10 ⁶ ... 10 ⁹ , depending on load		
Shock resistance:	30 g / 11 ms	50 g / 11 ms	30 g, sinusoidal oscillation BN 65-rz/V, -11rz/v: 15 g, sinusoidal oscillation
Vibration resistance:	10 ... 55 Hz, amplitude 1 mm		
Repeatability:	± 0.25 mm, T = constant		



5. Magnetic reed switches

5.10 Explanations

Vibration resistance

Although the adjustment of the bistable contact switch requires very high precision in comparison to the NO or NC contact switches, these units are extraordinarily vibration resistant. By embedding the switching tube receptacles in foam rubber, resistance to vibration is further increased. If the switch is under the influence of the actuating magnets, the switching condition will not be altered even by considerable vibrations. However caution must be observed in the case of heavy shock loads. When stress levels of this sort are too high, magnetic switches could become unable to operate because the contacts are permanently deformed.

Mechanical life

It must be ensured to that the meticulously tuned units are not damaged during installation or testing by overload. Reed switch contacts tend to weld when the maximum stated current is exceeded. Although they are able to operate after being separated, they definitely will have lost their accuracy and could furthermore have changed from NC contact to NO contact. If light bulbs or alternating current magnets are switched on, the inrush current peaks could amount to ten to twelve times the nominal current. When the inductance is turned off, overvoltage can occur which can quickly lead to a complete destruction of the devices. In such cases, the appropriate measures for spark extinguishing are to be carried out. In order to reduce the overload to an acceptable level, VDR-resistors can be wired parallel to the inductance. An attenuation resistor must be provided in all normal spark extinguishing procedures by capacitors because otherwise it can result in welding by the charging and discharging procedures of the capacitor. However, in some cases optimal values for the arc-extinguishing medium (R/C combination) can only be ascertained by testing. But it should not remain unsaid that an incorrect matching can be less favourable than none at all. For direct current power circuits, we recommend wiring a diode parallel to the inductance in order to protect the contacts. If the magnetic switches are protected from overloading, as described above, then one can expect an electrical contact life which surpasses those of the units to be switched by far. The non-contact functioning, low-force actuated switches are not subjected to any form of abrasion from the operating side and have thus a practically unlimited mechanical life.

NC contact

The installed bias magnet for this switch type is so strongly rated that the contacts are closed. By means of the opposite poling of the bias magnets to the actuating magnets, the opening of the contacts is caused when the actuating magnet approaches the switch. From this context, it can be recognised that the actuating magnets and the switches must be arranged in the prescribed manner (red on red and green on green). The field line diagrams for NO and NC contacts demonstrate that an actuation is possible

from three directions and that even a direction change of 90° will provide flawless functioning of the switch.

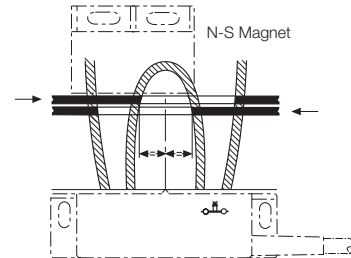

NC contact

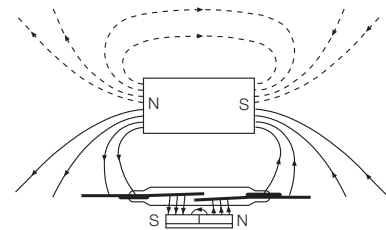

Combined effect of the magnetic field lines with an NC contact with N-S actuating magnets.

Bistable contact

This type of switch is obtained by an exact rating of the bias magnets. The force of these magnets on the reed contact is tuned so that it lies between the pull-in and the drop-out values of the reed contact. In order to make the tuning easier and to obtain a safe switching function, special reed contacts with a large difference between the pull-in and the drop-out values are used. The contact will remain open or closed without the influence of the actuating magnet. Prior to mounting, the desired contact function -NC contact or NO contact- can be established by actuation with an actuating magnet. The actuation, the closing or opening of the contacts, is carried out by the actuating magnets moving past the switch in the longitudinal direction - and only in the longitudinal direction. If, for example, the actuating magnet (N-pole) moves past the switch in the longitudinal direction from left to right, then it will finally land in a position (see illustration) in which the magnetic fields are mutually increased (field lines run in one direction in the vicinity of the contact tongues) by the actuating magnets and the bias magnets. Through this field increase, the pull-in value of the reed contact is surpassed and the contact tongues attract and close the contact. Should the actuating magnet continue in the same direction, its magnetic field will become increasingly weaker and will finally become ineffective for the switch. However, because the force of the bias magnets lies above the drop-out value of the reed contact, the contact remains closed. If the actuating magnet returns back, so that its centre point goes beyond the switch, then it reaches an area where the magnetic fields of the actuating magnet and bias magnets in the area of the contact tongues mutually weaken each other (field lines run in opposition). The drop-out value of the reed contact is not attained, and the contact opens. The bias magnets alone are not able to close the contact tongues, if the actuating magnet is moved out of the

5. Magnetic reed switches

5.10 Explanations

area of the switch, because its force lies below the pull-in value of the reed contact. The switch remains open. It shall be emphasised once more that faultless functioning with this type of switch can only be attained through a lateral passing of the N or S actuating magnets. No switching function will occur when transverse to the switch axis or upon proximity. A reversal of the switching function (right = open, left = closed) is obtained with this switch through a differently poled magnet (S-pole, see illustration).

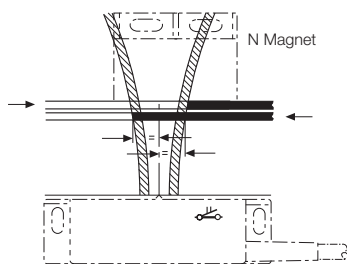

Bistable contact

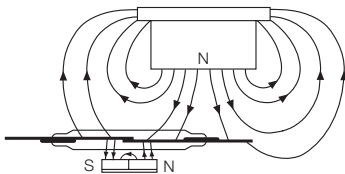

Combined effect of the magnetic field lines with a bistable contact with a N-magnet

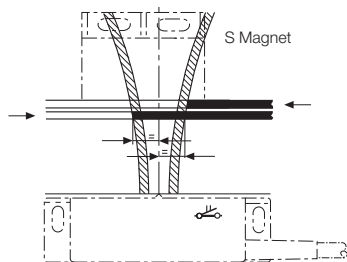

Bistable contact

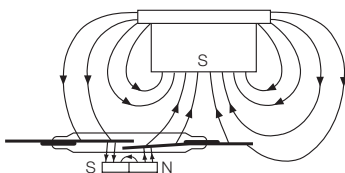

Combined effect of the magnetic field lines with a bistable contact with a S-magnet

Bistable changeover contact

The function of this type of contact corresponds with the normal bistable contact. For the following examination, only the NO contact side of the changeover contact will be considered for the sake of simplicity. If the actuating magnet is moved past the switch in the longitudinal direction, then the magnetic field lines of the actuating magnet are added together with those of the bias magnets. Through this addition, the pull-in value of the reed contact is surpassed, the contacts

Switch hysteresis

attract and then close the contact. When the actuating magnet continues in the same direction, the field becomes ineffective again for the switch. Because the force of the bias magnets lies above the drop-out value of the reed contact the switch remains closed. If the actuating magnet is returned again, so that its centre point goes beyond the switch, then the magnetic field lines work against those of the bias magnets, the drop-out value of the reed contact is not attained and the contact opens. If the actuating magnet continues, the magnetic field becomes ineffective for the switch. Because the force of the bias magnets lies under the pull-in value of the reed contact, the switch remains open. The described function demonstrates that in order to actuate the bistable contact and bistable changeover contacts, the actuating magnets can only be moved past the switch longitudinally. Corresponding to the movement direction and the desired switching function, N- or S-poled magnets are available. No switching function occurs when actuating magnets are moved transversely past the switch axis or upon proximity.

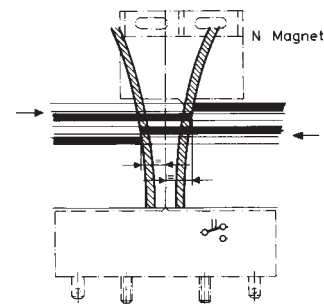

Bistable changeover contact

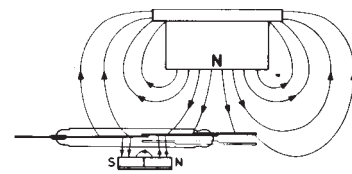

Combined effect of the magnetic field lines with a bistable changeover contact for closing.

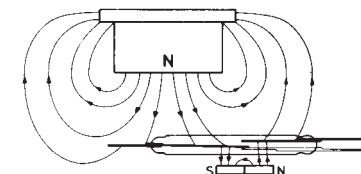

Combined effect of the magnetic field lines with a bistable changeover contact for opening.

5. Magnetic reed switches

5.10 Explanations

NO contact If the contacts are magnetised by a magnet which is approaching and thus influencing them (permanent or electromagnets), then after exceeding a specific pull-in force, they will attract each other. As a result of the air gap, decreasing during the closing procedure, the magnetic force increases quadratically, so that the contact closes by snap action. The opening occurs in the same manner when a specific drop-out value is not attained. The bias magnet of the NO contact prevents double switching, from those with the smallest actuating distances up to the magnet types whose maximum distance amounts to 25 mm. The bias magnets require a precise positioning of the actuating magnet to the switch - exactly according to specifications: colour symbols red on red and green on green!

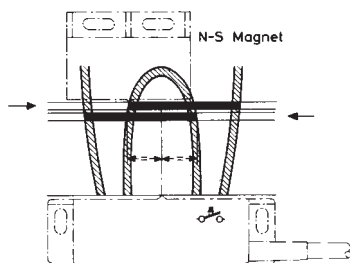

NO contact

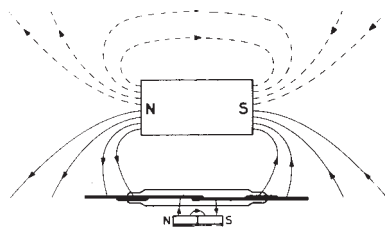

Combined effect of the magnetic field lines with a NO contact with N-S actuating magnets.

Changeover contact The general design of these reed contacts corresponds to the standard reed contacts. What differs is that the air gap between the contacts is slightly smaller (0.2 mm) than in the standard reed contact. The slightly lower vibration resistance and the lower dielectric strength are the results of this smaller air gap. The changeover contact can be treated like a working contact (NO contact), because the resting contact is made of non-magnetic material. For the functional sequence, see NO contact

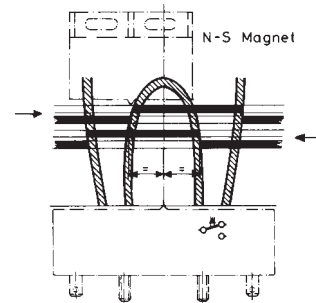

Changeover contact

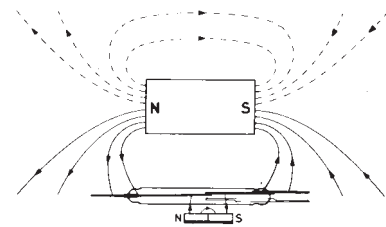

Combined effect of the magnetic field lines with a changeover contact with N-S actuating magnets.

Front actuation

In addition to the previously described manner of laterally actuating magnetic reed switches with a magnet, the switches of the BN 65 type series can be actuated laterally as well as from the front (suffix "V"). The switches with the contact types "NO", "NC" and "changeover" are as usual laterally actuated with a N-S magnet. All switches are marked on the same point with colour symbols which serve in showing the correct pairing and operation direction of the actuating magnets. Once again, here it applies: red on red and green on green. The front actuation for "NO", "NC" and "changeover" can only be carried out with a S-poled magnet. Therefore there is a red label with directional arrows on the face side. The switch with contact types "bistable", and "bistable changeover" are actuated laterally, as usual, with a N- or S-poled magnet, depending on the function. The colour coded symbols are also shown on the side of the switch which state the direction of operation. The front actuation for "bistable" and "bistable changeover" can only be carried out with a N-S magnet in the direction stated on the symbol label on the face side. By rotating the N-S magnet (magnet axis) by 180°, the bistability is changed to the opposite direction.

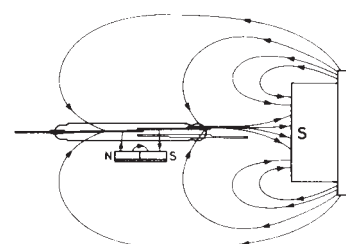

Front actuation