



EN Operating instructions..... pages 1 to 38
Translation of the original operating instructions

Content

1 About this document

1.1 Function 2

1.2 Target group: authorised qualified personnel 2

1.3 Explanation of the symbols used 2

1.4 Appropriate use 2

1.5 General safety instructions 2

1.6 Warning about misuse 2

1.7 Exclusion of liability 2

2 Product description

2.1 Ordering code enclosure 2

2.2 Ordering code operating push buttons (Elan) 4

2.3 Ordering code contact elements for operating push buttons (Elan) 4

2.4 Ordering code emergency stop command device EDR... 5

2.5 Ordering code emergency stop command device KDRR... 5

2.6 Ordering code emergency stop command device ADRR 40 5

2.7 Ordering code emergency stop command device EDRZ... 5

2.8 Ordering code emergency stop command device (Siemens) 5

2.9 Ordering code operating push buttons (Siemens) 5

2.10 Ordering code contact elements for operating push buttons (Siemens) 5

2.11 Ordering code safety monitoring module SRB 201 ZH 5

2.12 Special versions 5

2.13 Destination and use 5

3 Technical data

3.1 Technical data enclosure 6

3.2 Technical data operating push buttons 6

3.3 Technical data EDP... pushbutton 6

3.4 Technical data contact elements for EDP... 6

3.5 Technical data ADP... pushbutton 7

3.6 Technical data RF contact elements for ADP... 7

3.7 Technical data emergency stop command devices EDRR..., KDRR..., ADR..., EDRZ... (Elan) 7

3.8 Technical data of the EDRR... emergency stop command device 7

3.9 Technical data KDRR emergency stop command device 8

3.10 Technical data ADRR 40 emergency stop command device 8

3.11 Technical data EDRZ... emergency stop command device 9

3.12 Technical data operating push buttons and emergency stop command devices Siemens (inclusive contacts) 9

3.13 BWT sensor buttons (for fitting in Elan two-hand control panels of the SEPG 05.3..., SEPK 02.0... and SEP 09.0... type or as stand-alone variant) 10

3.14 Technical data safety-monitoring module SRB 201ZH 11

4 Classification

4.1 Safety classification 11

4.2 Safety classification of the SRB 201 ZH safety-monitoring module 12

4.3 Safety classification of EDRR..., KDRR..., ADRR 40, EDRZ... emergency stop command devices 12

5 Mounting

5.1 Mounting instructions for two-hand control panels 12

5.2 General mounting instructions for control elements 12

5.3 Mounting instructions for ADP... type control elements (ordering suffix E1 or E2) and ADRR40 type emergency stop command devices 13

5.4 Mounting instructions for EDRR EFR and KDRR EFR type emergency stop command devices 13

5.5 Mounting instructions for EDR type emergency stop command devices 13

5.6 Mounting instructions for BWT sensor button 13

5.7 Mounting instructions for the Siemens SIRIUS 3SB3 emergency stop actuator 15

5.8 Mounting instructions for the SRB 201ZH safety-monitoring module 16

6 Electrical connection

6.1 General information for electrical connection 16

6.2 Additions/notes for plastic two-hand control panels of the type SEPK02.0... 16

6.3 Additions/notes for die-cast aluminium (AL-226) two-hand control panels of the type SEPG05.3..... 17

6.4 Special wiring instructions for the STP02... stand 17

6.5 Electrical connection of the SRB 201ZH safety-monitoring module 17

7 Operating principle and settings

7.1 Operating principle and settings SRB 201ZH safety-monitoring module 17

8 Dimensions

8.1 Dimensions of the two-hand control panel SEPK02.0 18

8.2 Dimensions of the two-hand control panel SEPG 05.3 18

8.3 Dimensions of the two-hand control panel SEP01.0 18

8.4 Dimensions of the two-hand control panel SEP01.4 18

8.5 Dimensions of the two-hand control panel SEPLC05.2 18

8.6 Dimensions of the two-hand control panel SEP07.0 18

8.7 Dimensions of the two-hand control panel SEP09.0 19

8.8 Dimensions of the EDRR and KDRR emergency stop command device 19

8.9 Dimensions of the ADR 40 emergency stop command device 19

8.10 Dimensions of the EDRZ emergency stop command device 20

8.11 Dimensions of the sensor button BWT 20

8.12 Dimensions of the command devices/push buttons Siemens SIRIUS 3SB3 20

9 Electrical connection

9.1 Electrical connection of EDR, EFR, KDRR EFR and EDRZ emergency stop command devices 21

9.2 Electrical connection of ADRR 40 emergency stop command devices 21

9.3 Important notes for the 3SB3 Siemens SIRIUS emergency stop command device 21

10 Set-up and maintenance

10.1 Set-up and maintenance of the two-hand control panels 21

10.2 Putting into operation and maintenance EDR + EFR, KDRR + EFR, ADRR 40 and EDRZ emergency stop command devices 22

10.3 Set-up and maintenance safety-monitoring module SRB 201ZH 22

11 Disassembly and disposal

11.1 Disassembly of EDP... (ordering suffix E1 or E2) type control elements and ADRR 40 emergency stop command devices 22

11.2 Disassembly and disposal of the EDR + EFR, KDRR + EFR emergency stop command device	22
11.3 Disassembly and disposal of the EDRZ emergency stop command device	22
11.4 Disassembly of the Siemens SIRIUS emergency stop command devices, here: disassembly of the elements	22
11.5 Disassembly and disposal of the safety-monitoring module SRB 210ZH	23

12 Appendix

12.1 Wiring example safety monitoring module SRB 201ZH	23
12.2 EC Declaration of conformity BWT-1 / BWT-2	25
12.3 EC Declaration of conformity EDRR EFR	26
12.4 EC Declaration of conformity KDRR EFR	27
12.5 EC Declaration of conformity ADRR 40	28
12.6 EC Declaration of conformity EDRZ	29
12.7 EC Declaration of conformity 3SB3	30
12.8 EC Declaration of conformity SRB 201ZH	31
12.9 EC Declaration of conformity SEPK 02.0	32
12.10 EC Declaration of conformity SEPG 05.3	33
12.11 EC Declaration of conformity SEP 01.0	34
12.12 EC Declaration of conformity SEP 01.4	35
12.13 EC Declaration of conformity SEPLC 05.2	36
12.14 EC Declaration of conformity SEP 07.0	37
12.15 EC Declaration of conformity SEP 09.0	38

1 About this document

1.1 Function

This operating instructions manual provides all the information you need for the mounting, set-up and commissioning to ensure the safe operation and disassembly of the safety switchgear. The operating instructions must be available in a legible condition and a complete version in the vicinity of the device.

1.2 Target group: authorised qualified personnel

All operations described in this operating instructions manual must be carried out by trained specialist personnel, authorised by the plant operator only.

Please make sure that you have read and understood these operating instructions and that you know all applicable legislations regarding occupational safety and accident prevention prior to installation and putting the component into operation.

The machine builder must carefully select the harmonised standards to be complied with as well as other technical specifications for the selection, mounting and integration of the components.

1.3 Explanation of the symbols used



Information, hint, note:

This symbol is used for identifying useful additional information.



Caution: Failure to comply with this warning notice could lead to failures or malfunctions.

Warning: Failure to comply with this warning notice could lead to physical injury and/or damages to the machine.

1.4 Appropriate use

The products described in these operating instructions are developed to execute safety-related functions as part of an entire plant or machine. It is the responsibility of the manufacturer of a machine or plant to ensure the correct functionality of the entire machinery or plant.

The must be exclusively used in accordance with the versions listed below or for the applications authorised by the manufacturer. Detailed information regarding the range of applications can be found in the chapter "Product description".

1.5 General safety instructions

The user must observe the safety instructions in this operating instructions manual, the country-specific installation standards as well as all prevailing safety regulations and accident prevention rules.



Further technical information can be found in the Elan catalogues or in the online catalogue on the Internet: www.schmersal.net

The information contained in this operating instructions manual is provided without liability and is subject to technical modifications.

There are no residual risks, provided that the safety instructions as well as the instructions regarding mounting, commissioning, operation and maintenance are observed.



1.6 Warning about misuse

use or manipulations of the safety switchgear, personal hazards or damage to machinery or plant components cannot be excluded. The relevant requirements of the standard EN 13850 must be observed.

1.7 Exclusion of liability

We shall accept no liability for damages and malfunctions resulting from defective mounting or failure to comply with this operating instructions manual. The manufacturer shall accept no liability for damages resulting from the use of unauthorised spare parts or accessories.

For safety reasons, invasive work on the device as well as arbitrary repairs, conversions and modifications to the device are strictly forbidden; the manufacturer shall accept no liability for damages resulting from such invasive work, arbitrary repairs, conversions and/or modifications to the device.

2 Product description

2.1 Ordering code enclosure

This operating instructions manual applies to the following types:

SEPK 02.0.①.②.③/④.⑤

No.	Option	Description
①	4	Diameter of the command device heads (Elan)
	3	Diameter of the command device heads (Siemens)
	L	no command device mounted (empty enclosure with 3 × mounting hole Ø 22.3 mm)
②	S	Special version (with the following special ordering code)
	0	Command devices Elan
③	1	Command devices Siemens
	22	Mounting hole 22.3 mm
④	95	NC and NO contact of the mushroom-shaped pushbutton in separated form
	Z1	Emergency stop command device 2 NO + 2 NC
⑤	Z2	Switching interlock = yellow latching pushbutton instead of the red emergency stop command device (incl. label "switching interlock"), 1 NO + 1 NC
	Z3	Switching interlock = yellow latching pushbutton instead of the red emergency stop command device (incl. label "switching interlock"), 2 NO + 2 NC
Z4	Z4	Switching interlock = yellow latching pushbutton in addition to the red emergency stop command device (incl. label "switching interlock"), 1 NO + 1 NC
	Z5	Switching interlock = yellow latching pushbutton in addition to the red emergency stop command device (incl. label "switching interlock"), 2 NO + 2 NC
E2	E2	Ergonomic pushbutton (without spring in the device head) ADP55/3SW o.F., actuating force 7.0 N

BWT-1	Complete kit sensor button A + B, output cable 2 m, incl. connecting cable, without two-hand control panel
BWT-2	Complete kit sensor button A + B, output cable 5 m, incl. connecting cable, without two-hand control panel

Not all component variants, which are possible according to this order code, are available.

SEPG 05.3.①,②,③/④,⑤

No.	Option	Description
①	1	Diameter of the command device heads (Elan)
	2	Diameter of the command device heads (Elan or Elan + Siemens)
	3	Diameter of the command device heads (Elan or Siemens)
	4	Diameter of the command device heads (Elan)
L		no command device mounted (empty enclosure with 3 × mounting hole Ø 22.3 mm)
	S	Special version (with the following special ordering code)
②	0	Command devices Elan
	1	Command devices Siemens
③	22	Mounting hole 22.3 mm
④	95	NC and NO contact of the mushroom-shaped pushbutton in separated form
	⑤	Z1
Z2		Switching interlock = yellow latching pushbutton instead of the red emergency stop command device (incl. label "switching interlock"), 1 NO + 1 NC
	Z3	Switching interlock = yellow latching pushbutton instead of the red emergency stop command device (incl. label "switching interlock"), 2 NO + 2 NC
	Z4	Switching interlock = yellow latching pushbutton in addition to the red emergency stop command device (incl. label "switching interlock"), 1 NO + 1 NC
Z5	Switching interlock = yellow latching pushbutton in addition to the red emergency stop command device (incl. label "switching interlock"), 2 NO + 2 NC	
E1		Ergonomic pushbutton (with spring in the device head) ADP55/3SW, actuating force 10.5 N, 1 NC + 1 NO
	E2	Ergonomic pushbutton (without spring in the device head) ADP55/3SW o.F., actuating force 7.0 N, 1 NC + 1 NO
BWT-1	Complete kit sensor button A + B, output cable 2 m, incl. connecting cable, without two-hand control panel	
BWT-2	Complete kit sensor button A + B, output cable 5 m, incl. connecting cable, without two-hand control panel	

Not all component variants, which are possible according to this order code, are available.

SEP 01.0.①,②,③/④,⑤

No.	Option	Description
①	1	Diameter of the command device heads (Elan)
	2	Diameter of the command device heads (Elan or Elan + Siemens)
	3	Diameter of the command device heads (Elan or Siemens)
	4	Diameter of the command device heads (Elan)

L	no command device mounted (empty enclosure with 3 × mounting hole Ø 22.3 mm)	
S	Special version (with the following special ordering code)	
②	0	Command devices Elan
	1	Command devices Siemens
③	22	Mounting hole 22.3 mm
	30	Mounting hole 30.5 mm
④	95	NC and NO contact of the mushroom-shaped pushbutton in separated form
	⑤	Z1
Z2	Switching interlock = yellow latching pushbutton instead of the red emergency stop command device (incl. label "switching interlock"), 1 NO + 1 NC	
Z3	Switching interlock = yellow latching pushbutton instead of the red emergency stop command device (incl. label "switching interlock"), 2 NO + 2 NC	
Z4	Switching interlock = yellow latching pushbutton in addition to the red emergency stop command device (incl. label "switching interlock"), 1 NO + 1 NC	
Z5	Switching interlock = yellow latching pushbutton in addition to the red emergency stop command device (incl. label "switching interlock"), 2 NO + 2 NC	
E1	Ergonomic pushbutton (with spring in the device head) ADP55/3SW, actuating force 10.5 N, 1 NC + 1 NO	
E2	Ergonomic pushbutton (without spring in the device head) ADP55/3SW o.F., actuating force 7.0 N, 1 NC + 1 NO	

Not all component variants, which are possible according to this order code, are available.

SEP 01.4.①,②,③/④,⑤

No.	Option	Description
①	1	Diameter of the command device heads (Elan)
	2	Diameter of the command device heads (Elan or Elan + Siemens)
	3	Diameter of the command device heads (Elan or Siemens)
	4	Diameter of the command device heads (Elan)
L		no command device mounted (empty enclosure with 3 × mounting hole Ø 22.3 mm)
	S	Special version (with the following special ordering code)
②	0	Command devices Elan
	1	Command devices Siemens
③	22	Mounting hole 22.3 mm
	30	Mounting hole 30.5 mm
④	95	NC and NO contact of the mushroom-shaped pushbutton in separated form
	⑤	Z1
Z2	Switching interlock = yellow latching pushbutton instead of the red emergency stop command device (incl. label "switching interlock"), 1 NO + 1 NC	
Z3	Switching interlock = yellow latching pushbutton instead of the red emergency stop command device (incl. label "switching interlock"), 2 NO + 2 NC	
Z4	Switching interlock = yellow latching pushbutton in addition to the red emergency stop command device (incl. label "switching interlock"), 1 NO + 1 NC	

Z5	Switching interlock = yellow latching pushbutton in addition to the red emergency stop command device (incl. label "switching interlock"), 2 NO + 2 NC
E1	Ergonomic pushbutton (with spring in the device head) ADP55/3SW, actuating force 10.5 N, 1 NC + 1 NO
E2	Ergonomic pushbutton (without spring in the device head) ADP55/3SW o.F., actuating force 7.0 N, 1 NC + 1 NO

Not all component variants, which are possible according to this order code, are available.

SEPLC 05.2.①.②.③/④.⑤

No.	Option	Description
①	1	Diameter of the command device heads (Elan)
	2	Diameter of the command device heads (Elan or Elan + Siemens)
3	3	Diameter of the command device heads (Elan or Siemens)
	4	Diameter of the command device heads (Elan)
L		no command device mounted (empty enclosure with 3 × mounting hole Ø 22.3 mm)
S		Special version (with the following special ordering code)
②	0	Command devices Elan
	1	Command devices Siemens
③	22	Mounting hole 22.3 mm
	30	Mounting hole 30.5 mm
④	95	NC and NO contact of the mushroom-shaped pushbutton in separated form
	Z1	Emergency stop command device 2 NO + 2 NC
⑤	Z2	Switching interlock = yellow latching pushbutton instead of the red emergency stop command device (incl. label "switching interlock"), 1 NO + 1 NC
	Z3	Switching interlock = yellow latching pushbutton instead of the red emergency stop command device (incl. label "switching interlock"), 2 NO + 2 NC
Z4		Switching interlock = yellow latching pushbutton in addition to the red emergency stop command device (incl. label "switching interlock"), 1 NO + 1 NC
Z5		Switching interlock = yellow latching pushbutton in addition to the red emergency stop command device (incl. label "switching interlock"), 2 NO + 2 NC
E1		Ergonomic pushbutton (with spring in the device head) ADP55/3SW, actuating force 10.5 N, 1 NC + 1 NO
E2		Ergonomic pushbutton (without spring in the device head) ADP55/3SW o.F., actuating force 7.0 N, 1 NC + 1 NO
Z6		Prepunched, removable AI panel with a total of 11 mounting holes Ø 22.3 mm
Z7		Prepunched, removable AI panel with a total of 11 mounting holes Ø 22.3 mm, additional mounting holes sealed with round blanking plugs

Not all component variants, which are possible according to this order code, are available.

SEP 09.0.①.②.③/④.⑤

No.	Option	Description
①	1	Diameter of the command device heads (Elan)
	3	Diameter of the command device heads (Elan or Elan + Siemens)
L		no command device mounted (empty enclosure with 3 × mounting hole Ø 22.3 mm)

S	Special version (with the following special ordering code)	
②	0	Command devices Elan
	1	Command devices Siemens
③	22	Mounting hole 22.3 mm
	30	Mounting hole 30.5 mm
④	95	NC and NO contact of the mushroom-shaped pushbutton in separated form
	E1	Ergonomic pushbutton (with spring in the device head) ADP55/3SW, actuating force 10.5 N, 1 NC + 1 NO
E2		Ergonomic pushbutton (without spring in the device head) ADP55/3SW o.F., actuating force 7.0 N, 1 NC + 1 NO
BWT-1		Complete kit sensor button A + B, output cable 2 m, incl. connecting cable, without two-hand control panel
BWT-2		Complete kit sensor button A + B, output cable 5 m, incl. connecting cable, without two-hand control panel

Not all component variants, which are possible according to this order code, are available.

2.2 Ordering code operating push buttons (Elan)

EDP①SW + EF03.1 + EF10.1

No.	Option	Description
		black, mounting diameter 22.3 mm, in combination with EF03.1 + EF10.1 switching elements (1 NO + 1 NC, in separated form) or EF033.1 + EF110.1 (2 NO + 2 NC, in separated form)
①	42	Head diameter 42 mm
	55	Head diameter 55 mm

ADP55/3SW ① + RF03 + RF10

No.	Option	Description
		black, mounting diameter 22.3 mm, in combination with RF03 + RF10 switching elements (1 NO + 1 NC, in separated form)
①	oF	without spring in the head

Not all component variants, which are possible according to this order code, are available.

2.3 Ordering code contact elements for operating push buttons (Elan)

EF①.1

No.	Option	Description
①	03	NO element in combination with EF10.1 switching element = 1 NO + 1 NC, in separated form
	033	NO element in combination with EF10.1 switching element = 2 NO + 2 NC, in separated form
10		NC element in combination with EF03.1 switching element = 1 NO + 1 NC, in separated form

RF

No.	Option	Description
①	03	NO element in combination with RF10 switching element = 1 NO + 1 NC, in separated form
	10	NC element in combination with RF03 switching element = 1 NO + 1 NC, in separated form

Not all component variants, which are possible according to this order code, are available.

2.4 Ordering code emergency stop command device EDR...

EDR ^{① ② ③ ④} EFR		
No.	Option	Description
①	R	latching only in combination with EFR, turn and pull to unlock
	RZ	latching only in combination with EFR, turn to unlock
	RS	with cylinder lock, unlocking only by key, only by pulling, with EFR
②	50	Head diameter 49 mm
	40	Head diameter 38.5 mm
③		Mounting hole 22,3 mm
	VH	Mounting hole 30,5 mm
④	RT	Red colour

Not all component variants, which are possible according to this order code, are available.

2.5 Ordering code emergency stop command device KDRR...

KDRR ^{① ② ③ ④} EFR		
No.	Option	Description
①	K	Plastic device head, release by turning and pulling
	KZ	Release by pulling only
②	40	Head diameter 38.5 mm
	50	Head diameter 49 mm
③		Mounting hole 22,3 mm
	VH	Mounting hole 30,5 mm
④	RT	Red colour

Not all component variants, which are possible according to this order code, are available.

2.6 Ordering code emergency stop command device ADRR 40

ADRR ^{① ② ③}		
No.	Option	Description
①	R	Release by pulling
②	40	Head diameter 40 mm
③	RT	Red colour

Not all component variants, which are possible according to this order code, are available.

2.7 Ordering code emergency stop command device EDRZ...

EDRZ ^{① ② ③}		
No.	Option	Description
		Release by pulling only
①	40	Head diameter 38.5 mm
		Mounting hole 22,3 mm
②	VH	Mounting hole 30,5 mm
	RT	Red colour

Not all component variants, which are possible according to this order code, are available.

2.8 Ordering code emergency stop command device (Siemens)

3SB3000-1HA20		
No.	Option	Description
		Command device, red colour, mounting diameter 22.3 mm, head diameter 40 mm, in combination with 3SB3400OB + 3SB3400OC switching elements (1 NO + 1 NC) or 3SB3400-OD + 3SB3400-OE (2 NO + 2 NC, in separated form)

2.9 Ordering code operating push buttons (Siemens)

3SB3000-1GA11		
No.	Option	Description
		black, mounting diameter 22.3 mm, head diameter 40 mm, in combination with 3SB3400OB + 3SB3400OC switching elements (1 NO + 1 NC) or 3SB3400-OD + 3SB3400-OE (2 NO + 2 NC, in separated form)

2.10 Ordering code contact elements for operating push buttons (Siemens)

3SB3400-O ^①		
No.	Option	Description
①	B	NO element: in combination with 3SB3400-OC switching element = 1 NO + 1 NC
	C	NC element: in combination with 3SB3400-OB switching element = 1 NO + 1 NC
	D	NO element in combination with 3SB3400-OE switching element = 2 NO + 2 NC, in separated form
	E	NC element: in combination with 3SB3400-OD switching element = 2 NC + 2 NO, in separated form
AF		
①	02	NO element in combination with AF10 switching element = 1 NO + 1 NC, in separated form
	10	NC element in combination with AF02 switching element = 1 NO + 1 NC, in separated form

2.11 Ordering code safety monitoring module SRB 201 ZH

This operating instructions manual applies to the following types:

SRB 201ZH



Only if the information described in this operating instructions manual are realised correctly, the safety function and therefore the compliance with the Machinery Directive is maintained.

2.12 Special versions

For special versions, which are not listed in the order code below 2.1, these specifications apply accordingly, provided that they correspond to the standard version.

2.13 Destination and use

The two-hand control panels of the series SEPK 02.0 / SEPG 05.3 / SEP 01.0 / SEP 01.4 / SEPLC 05.2 / SEP 07.0 / SEP 09.0 are used on machinery and plants as safe command device (as man-machine interface).

3 Technical data

3.1 Technical data enclosure

Standards:	conform to DIN EN 574
Materials:	Al sand casting powder-coated RAL 7004; Al die-cast (AL-226) powder-coated RAL 7004; plastic (Lexan 503R), painted in RAL 7035 (only limited resistance to oil and drill emulsion)
Protection class:	The IP protection class mentioned on the identification label can only be guaranteed, if the enclosures are completely equipped with corresponding command and signalling devices.
Control voltage:	max. 230 V
Approvals:	BG prototype testing + UL and CSA approval for all default enclosure to List ZHS/08 (exception: SEPLC 05.2 and SEP 09.0 type panels)
Rohs compliant:	Yes

3.2 Technical data operating push buttons

EDP42SW + EF03.1 + EF10.1	black, mounting diameter 22.3 mm, head diameter 42 mm, 1 NC + 1 NO (in separated form)
EDP55SW + EF03.1 + EF10.1	black, mounting diameter 22.3 mm, head diameter 55 mm, 1 NC + 1 NO (in separated form)
ADP55/3SW + RF03 + RF10	black, mounting diameter 22.3 mm, head diameter 55 mm, 1 NC + 1 NO (in separated form)
ADP55/3SW oF + RF03 + RF10	black, mounting diameter 22.3 mm, head diameter 55 mm, 1 NC + 1 NO (in separated form)

3.3 Technical data EDP... pushbutton

Standards:	IEC/EN 60947-5-1, IEC 60947-1
Design:	round
Installation diameter:	22.3 mm
Spacing:	40 × 50 mm; selector switch, latching pushbutton: 50 × 60 mm
Front plate thickness:	1 ... 6 mm
Mounting position:	any
Device labelling:	Labels, symbols
Climate resistance:	to DIN EN 60068 Part 2-30
Ambient temperature:	-25 °C ... +75 °C
Switching frequency:	1,000 s/h
Protection class:	to IEC 60529: IP65
Fully insulated:	Yes
Materials	Front ring/buttons: Al anodised
Fixation:	with mounting flange
Tightening torque:	0.6 Nm tightening torque for the EFM/ELM fixing screws
Resistance to shock:	to IEC 60068-2-27: < 50 g
Resistance to vibrations:	to IEC 60068-2-6: 5 g
Actuating stroke:	4 mm
Actuating force:	typ. 2 N
Mechanical life:	10 × 10 ⁶ operations
Rohs compliant:	Yes
Temperature range:	-25 °C ... +75 °C

3.4 Technical data contact elements for EDP...

Standards:	EN IEC 60947-5-1, EN IEC 60947-1, EN 50274, BGV A2, DIN 50015, DIN 50016, DIN 50005, VDE 0106, VBG 4
Nominal insulation voltage:	400 VAC / 450 VDC (1-pole versions: 500 VAC / 600 VAC)
Electronic control circuits:	≥ 5 V / 3.2 mA
Insulation group:	4 kV / 3
Test voltage:	2,500 VAC
Galvanically separated contact bridges:	Yes
Thermal nominal current:	10 A
Nominal switch-on capacity:	AC-13: 66 A
Nominal switch-off capacity:	230 VAC: typ.6 A 400 VAC: typ.4 A
Operating current I _e :	230 VAC: typ.6 A 400 VAC: typ.4 A
Max. fuse rating:	10 A slow blow
Contact life:	10 VA cos φ 0,4/W ind.40 ms: AC-15 = 30 × 10 ⁶ ; DC-13 = 5 × 10 ⁶ ; 25 VA cos φ 0,4/W ind.40 ms: AC-15 = 10 × 10 ⁶ ; DC-13 = 2 × 10 ⁶ ; 100 VA cos φ 0,4/W ind.40 ms: AC-15 = 7 × 10 ⁶ ; DC-13 = 0,7 × 10 ⁶ ; 500 VA cos φ 0,4/W ind.40 ms: AC-15 = 2 × 10 ⁶ ; DC-13 = 0,1 × 10 ⁶ ;
Protection class:	Terminals: IP 20 (finger guard; with plug-in connector depending on the connector plug used) Wiring compartments: IP40
Switching frequency:	6,000 s/h
Resistance to shock:	110 g / 4 ms ... 30 g / 18 ms, no bouncing
Resistance to vibrations:	> 20 g / 10 ... 200 Hz (for actuating heads with higher mass accordingly lower)
Bounce duration (100 mm/s):	< 5 ms
Temperature range:	-25 °C ... +80 °C
Climate resistance:	DIN 50015 : up to condensation 40/9; DIN 50016: FW 24
Terminal designations:	to DIN EN 50005
Contact and connecting parts:	Fine silver, phosphorus bronze or Ms carrier
Contact force:	0.5 N each contact point ≅ 2 N each contact bridge
Actuating force:	at 2 mm switch travel: 4 N at 4 mm switch travel: 7 N at 6 mm switch travel: 9 N
Shock-protection:	to VDE 0106, VBG 4
Rated operating voltage U _e max.:	400 V
Rated insulation voltage U _i :	for degree of pollution 3 to EN 60947-1: 400 V
Rated impulse withstand voltage U _{imp} :	4 kV
Thermal nominal current I _{th} (in air):	6 A
Operating current I _e :	Depending on the utilisation category and the rated operating voltage U _e : 8 A: AC-15, 250 VAC 5 A: DC-13, 24 VDC (restriction: cable section max. 1 × 2.5 mm ² – only identical sections may be used)
Contact reliability:	5 VDC / 1 mA
Max. fuse rating:	gG 6 A
Evidence of the positive break:	2.5 kV impulse voltage
Positive break travel:	typ. approx. 2 mm after the opening point
Air clearances and creepage distances:	4 kV / 3

Switching points:	NC contact: typ.1 mm NO contact: typ.2.5 mm
Mounting position:	any
Mechanical life:	10 × 10 ⁶ operations
Actuating force at stroke end:	typ. 4.5 N
Connection:	Screw terminals
Cable section:	solid wire: 2 × (2 ... 2 mm ²) stranded wire (with conductor ferrules): 2 × (2 ... 2 mm ²)
Tightening torque:	Connecting screw: max. 1 Nm
Shock-protection:	available (save illuminated element individually mounted)
Approvals:	cULus (under preparation)

3.5 Technical data ADP... pushbutton

Standards:	IEC 947, EN IEC 60947, DIN VDE 0660, DIN EN 50007, DIN EN 60068
Installation diameter:	22.3 mm
Front plate area:	1 ... 6 mm
Connection:	Knurled nut, central mounting
Max. tightening torque:	1 Nm
Mounting position:	any
Temperature range:	-25 °C ... +60 °C
Climate resistance:	to DIN EN 60068 Part 2-30
Protection class:	IP 65
Sealing type:	Lip gaskets, flat gaskets
Fully insulated:	Yes
Materials:	PA GV
Front ring execution:	PA GV

3.6 Technical data RF contact elements for ADP...

Standards:	EN IEC 60947, DIN VDE 0660, DIN EN 60664, DIN EN 60068
Rated operating voltage U _e max.:	400 V
Utilisation category:	AC-13, DC-15
Operating current I _e :	depending on the utilisation category and the test voltage: 8 A: AC-15, 250 VAC 5 A: DC-13, 24 VDC
Thermal nominal current I _{th} (in air):	10 A
Max. fuse rating:	gG 10 A
Air clearances and creepage distances	4 kV/3
Evidence of the positive break:	2.5 kV impulse voltage
Positive break travel:	typ. approx. 2 mm after the opening point
Switching of low voltages	min. 24 VDC / 5 mA
Switching frequency to:	1,200 s/h
Temperature range:	-25°C ... +60°C
Climate resistance:	Part 2-30
Mounting position:	any
Mechanical life:	10 × 10 ⁵ operations
Switch travel:	typ.3.5 mm
Resistance to shock:	30 g / 16 ms
Resistance to vibrations:	20 g / 10 ... 150 Hz
Wiring configuration:	to EN 60947
Actuating force at stroke end:	typ. 9 N
Switching points:	NC contact: typ.1 mm NO contact: typ.2.5 mm
Enclosure material:	PA GV self-extinguishing, hardly flammable
Connection:	Screw terminals
Cable section:	solid wire: 2 × (2 ... 2 mm ²) stranded wire with conductor ferrules: 2 × (2 ... 2 mm ²)

Tightening torque:	Connecting screw max. 1 Nm
Rated insulation voltage U _i :	for degree of pollution 3: 400 V
Protection class:	Connections: IP 20 (finger-safe) Switching elements: IP 40
Protection against accidental contact with live parts:	available (to EN 50274 and BGV A2)
Approvals:	cULus

3.7 Technical data emergency stop command devices EDRR..., KDRR..., ADR..., EDRZ... (Elan)

EDRR40RT + EFR + EF303.1	Command device, red colour, mounting diameter 22.3 mm, head diameter: 38.5 mm, 1 NO + 1 NC
EDRR50RT + EFR + EF303.1	Command device, red colour, mounting diameter 1 mm, head diameter: 1 mm, 1 NO + 1 NC
KDRRK40RT + EFR + EF303.1	Command device, red colour, mounting diameter 22.3 mm, head diameter: 38.5 mm, 1 NO + 1 NC
ADRRRT + RF10 + RF03	Command device, red colour, mounting diameter 22.3 mm, head diameter: 40 mm, 1 NO + 1 NC
EDRZ40RT + EF303.1	Command device, red colour, mounting diameter 1 mm, head diameter: 1 mm, 1 NO + 1 NC
EF033.1 + EF220.1	Switching elements, 2 NO + 2 NC (in separated form)
EF303.1 + EF303.2	Switching elements, 2 NO + 2 NC (for emergency stop)
RF10 + RF10 + RF03 + RF03	Switching elements, 2 NO + 2 NC (for A-programme emergency stop with maximum equipment)

3.8 Technical data of the EDRR... emergency stop command device

Standards	IEC 60947-5-1, IEC 60947-5-5, IEC 60947-1, EN ISO 13850
Design	round
Mounting Ø	22.3 mm
Spacing	for head Ø 40 mm: 50 × 40 mm, for head Ø 50 mm: 50 × 50 mm
Front plate thickness	1 ... 6 mm
Mounting position	any
Climate resistance to DIN EN 60068	Part 2-30
Ambient temperature	-25 °C ... +75 °C
Protection class to IEC 605290	IP65
Fully insulated	yes
Material mushroom button	Al anodised
Fixing	with mounting flange
Max. tightening torque for the ELM fixing screws	0.6 Nm
Actuating force	approx. 25 N
Mechanical life	1 × 10 ⁵ operations
Rohs compliant:	yes
Contact elements	
Standards	IEC/EN 60947-5-1
Rated operating voltage U _e max.:	400 V
Rated insulation voltage U _i for degree of pollution 3 to EN 60947-1:	400 V
Rated impulse withstand voltage U _{imp} :	4 kV
Thermal nominal current I _{th} (in air):	10 A

Rated operating current le depending on the utilization category and rated operation voltage U_e :	8 A, AC-15, 250 VAC 5 A, DC-13, 24 VDC
Contact reliability	5 VDC / 1 mA
Max. fuse rating	gG 10 A
Evidence of the positive break	2.5 kV impulse voltage
positive break travel	approx. 2 mm after the opening point
Air clearances and creepage distances to DIN EN 60664 1	4 kV/3
Switching points	depending on the contact execution
Temperature range	-25 °C ... +60 °C
Climate resistance to DIN EN 60068	Part 2-30
Mounting position	any
Mechanical life	10 × 10 ⁶ operations
Actuating force at stroke end	approx. 9 N
Terminal labelling	to IEC 60947-1
Termination	Screw terminals Flat plug-in connector Clamp connection
Cable section	solid wire: 2 × (2 ... 2 mm ²) stranded wire (with conductor ferrules): 2 × (0,5 ... 1.5 mm ²)
Tightening torque for the connecting screw	max. 1 Nm
Shock-protection	available (to EN 50274 and BGV A2)
Protection class	Connections: IP 20 (finger-safe) Switching elements: IP40
Approvals	cULus (save cage clamp connection)

3.9 Technical data KDRR emergency stop command device

Standards	IEC 60947-5-1, IEC 60947-5-5, IEC 60947-1, EN ISO 13850
Design	round
Mounting \varnothing	22.3 mm
Spacing	for head \varnothing 40 mm: 50 × 40 mm, for head \varnothing 50 mm: 50 × 50 mm
Front plate thickness	1 ... 6 mm
Mounting position	any
Climate resistance to DIN EN 60068	Part 2-30
Ambient temperature	-25 °C ... +75 °C
Protection class to IEC 605290	IP 65
Fully insulated	yes
Material mushroom button	Al plastic
Fixing	with mounting flange
Max. tightening torque for the ELM fixing screws	0.6 Nm
Actuating force	approx. 25 N
Mechanical life	1 × 10 ⁵ operations
Rohs compliant:	yes
Contact elements	
Standards	IEC/EN 60947-5-1
Rated operating voltage U_e max.:	400 V
Rated insulation voltage U_i for degree of pollution 3 to EN 60947-1:	400 V
Rated impulse withstand voltage U_{imp} :	4 kV

Thermal nominal current I_{th} (in air):	10 A
Rated operating current le depending on the utilization category and rated operation voltage U_e :	8 A, AC-15, 250 VAC 5 A, DC-13, 24 VDC
Contact reliability	5 VDC / 1 mA
Max. fuse rating	gG 10 A
Evidence of the positive break	2.5 kV impulse voltage
positive break travel	approx. 2 mm after the opening point
Air clearances and creepage distances to DIN EN 60664 1	4 kV/3
Switching points	depending on the contact execution
Temperature range	-25 °C ... +60 °C
Climate resistance to DIN EN 60068	Part 2-30
Mounting position	any
Mechanical life	10 × 10 ⁶ operations
Actuating force at stroke end	approx. 9 N
Terminal labelling	to IEC 60947-1
Termination	Screw terminals Flat plug-in connector Clamp connection
Cable section	solid wire: 2 × (2 ... 2 mm ²) stranded wire (with conductor ferrules): 2 × (0,5 ... 1.5 mm ²)
Tightening torque for the connecting screw	max. 1 Nm
Shock-protection	available (to EN 50274 and BGV A2)
Protection class	Connections: IP20 (finger-safe) Switching elements: IP40
Approvals	cULus (save cage clamp connection)

3.10 Technical data ADRR 40 emergency stop command device

Standards	IEC 947, EN 60947, DIN VDE 0660
Design	round, palm form
Installed \varnothing	22.3 mm
to DIN EN 50 007:	
Spacing	50 × 40 mm
Front plate area	1 ... 6 mm
Connection:	Knurled nut, central mounting
Max. tightening torque for mounting	1 Nm
Mounting position	any
Temperature range	-25 °C ... +60 °C
Climate resistance	to DIN EN 60068, Part 2-30
Protection class	IP 65
Sealing type	Lip gaskets, flat gaskets
Fully insulated	yes
Material	PA GV
Front ring execution	PA GV
Max. tightening torque for the knurled nut	1 Nm
Contact elements	
Standards	IEC/EN 60947-5-1
Rated operating voltage U_e max.:	400 V
Rated insulation voltage U_i for degree of pollution 3 to EN 60947-1:	400 V
Rated impulse withstand voltage U_{imp} :	4 kV
Thermal nominal current I_{th} (in air):	10 A

Rated operating current le depending on the utilization category and rated operation voltage the test voltage U_e :	8 A, AC-15, 250 VAC 5 A, DC-13, 24 VDC
Contact reliability	5 VDC / 1 mA
Max. fuse rating	gG 10 A
Evidence of the positive break	2.5 kV impulse voltage
positive break travel	approx. 2 mm after the opening point
Air clearances and creepage distances to DIN EN 60664 1	4 kV/3
Switching points	depending on the contact execution
Temperature range	-25 °C ... +60 °C
Climate resistance to DIN EN 60068	Part 2-30
Mounting position	any
Mechanical life	10 × 10 ⁶ operations
Actuating force at stroke end	approx. 9 N
Terminal labelling	to IEC 60947-1
Termination	Screw terminals Flat plug-in connector Clamp connection
Cable section	solid wire: 2 × (2 ... 2 mm ²) stranded wire (with conductor ferrules): 2 × (0,5 ... 1.5 mm ²)
Tightening torque for the connecting screw	max. 1 Nm
Shock-protection	available (to EN 50274 and BGV A2)
Protection class	Connections: IP20 (finger-safe) Switching elements: IP40
Approvals	cULus (save cage clamp connection)
Approvals	UL / CSA

3.11 Technical data EDRZ... emergency stop command device

Standards	IEC 60947-5-1, IEC 60947-5-5, IEC 60947-1, EN ISO 13850
Design	round
Mounting \varnothing	22.3 mm
Spacing	for head \varnothing 40 mm: 50 × 40 mm, for head \varnothing 50 mm: 50 × 50 mm
Front plate thickness	1 ... 6 mm
Mounting position	any
Climate resistance to DIN EN 60068	Part 2-30
Ambient temperature	-25 °C ... +75 °C
Protection class to IEC 605290	IP65
Fully insulated	yes
Material mushroom button	Al anodised
Fixing	with mounting flange
Max. tightening torque for the ELM fixing screws	0.6 Nm
Actuating force	approx. 25 N
Mechanical life	1 × 10 ⁵ operations
Rohs compliant:	yes
Contact elements	
Standards	IEC/EN 60947-5-1
Rated operating voltage U_e max.:	400 V
Rated insulation voltage U_i for degree of pollution 3 to EN 60947-1:	400 V
Rated impulse withstand voltage U_{imp} :	4 kV
Thermal nominal current I_{th} (in air):	10 A

Rated operating current le depending on the utilization category and rated operation voltage the test voltage U_e :	8 A, AC-15, 250 VAC 5 A, DC-13, 24 VDC
Contact reliability	5 VDC / 1 mA
Max. fuse rating	gG 10 A
Evidence of the positive break	2.5 kV impulse voltage
positive break travel	approx. 2 mm after the opening point
Air clearances and creepage distances to DIN EN 60664 1	4 kV/3
Switching points	depending on the contact execution
Temperature range	-25 °C ... +60 °C
Climate resistance to DIN EN 60068	Part 2-30
Mounting position	any
Mechanical life	10 × 10 ⁶ operations
Actuating force at stroke end	approx. 9 N
Terminal labelling	to IEC 60947-1
Termination	Screw terminals Plug-in terminals Clamp terminals
Cable section	solid wire: 2 × (0.5 ... 2.5 mm ²) stranded wire (with conductor ferrules): 2 × (0.5 ... 1.5 mm ²)
Tightening torque for the connecting screw	max. 1 Nm
Shock-protection	available (to EN 50274 and BGV A2)
Protection class	Connections: IP 20 (finger-safe) Wiring compartments: IP 40
Approvals	cULus (save cage clamp connection)

3.12 Technical data operating push buttons and emergency stop command devices Siemens (inclusive contacts)

3SB3000-1GA11 + 3SB3400-OB + 3SB3400-OC	Control element, black colour, mounting diameter 22.3 mm, head diameter 40 mm, 1 NO + 1 NC
3SB3000-1HA20 + 3SB3400-OB + 3 SB3400-OC	Command device, red colour, mounting diameter 22.3 mm, head diameter: 40 mm, 1 NO + 1 NC
3SB3400-OD + 3SB3400-OE	Switching elements, 2 NO + 2 NC (in separated form)
Ambient temperature:	If LED's or non-illuminated devices are used: -25°C ... +70°C If illuminated devices (with lamp) are used: -25°C ... +60°C storage/transport: -40°C ... +80°C
Climate resistance:	Climate resistance KTW24 to DIN 50017, suitable for use in marine plants
Rated insulation voltage U_i :	Screw connection and cage clamps: 400 V Soldering terminals: 250 V illuminated washer: 32 V
Rated impulse withstand voltage U_{imp} :	Screw connection and cage clamps: 6 kV Soldering terminals: 4 kV illuminated washer: 0.8 kV
Restistance to shock to IEC 60068 Teil 2-27	Shock duration: 11 ms / half-sinus Devices without illuminant: ≤ 50 g Devices with illuminant: ≤ 30 g
Resistance to vibrations to EN 60068-2-6:	Frequency: 20 ... 200 Hz Cycles: 10 Acceleration: 5 g
Degree of pollution to IEC 60947-1:	Class 3

Shock-protection:	Soldering terminals: connection of the switching elements and lamp fitting behind the front plate Screw connection and cage clamps: finger-safe to VDE 0660 Part 514 or BGV A3
Protection class to IEC 60529 (VDE 0470 part 1):	Connection of the switching elements and lamp fitting behind the front plate: IP20 Switching compartments of the switching elements behind the front plate: IP40 Acoustic warning device 3SB3000-7AA10: IP40 Cylinder lock with key monitoring: IP54 Double pushbutton, acoustic warning device 3SB323-7BA10: IP65 Pushbutton with extended travel: IP65 Illuminated washer: IP65 Actuator and warning device in moulding material: IP66 with protective covers: IP67 Actuator and warning device in metal: IP67 / Nema type 4
Mechanical life:	Pushbuttons and switching elements (without monitored switching element): 10×10^6 Actuating elements rotatable or latching: 3×10^5 Illuminated pushbutton: 3×10^6 Cylinder lock with key monitoring: 1×10^5
Electrical life:	for utilisation category AC-15 with contactors 3RT1015 up to 3RT1026: 10×10^6 for utilisation category DC-12, DC-13: in case of direct current, the life depends both on the switch-off current and the voltage, the inductivity of the electrical circuit and the switching speed.
Switching frequency:	1,000 s/h
Conventional thermal current I_{th} :	10 A
Rated operating voltage U_e :	24 V / 48 V / 110 V / 230 V / 400 V
Rated operating current I_e at alternating current 50 / 60 Hz:	AC-12, Screws connection / cage clamps: 10 A AC-12, Soldering terminal: 24 ... 230 V = 10 A AC-15, Screws connection / cage clamps: 24 ... 230 V = 6 A; 400 V = 3 A AC-15, Soldering terminal: 24 ... 230 V = 4 A
Operating current I_e at direct current:	DC-12, screw connection/soldering terminals/cage clamps: 24 V = 10 A; 48 V = 5 A; 110 V = 2.5 A; 230 V = 1 A DC-13, screw connection/soldering terminal/cage clamps: 24 V = 3 A; 48 V = 1.5 A; 110 V = 0.7 A; 230 V = 0.3 A
Contact reliability test voltage/test current:	5 V / 1 mA
Max. fuse rating (without any contact welding to IEC 60947-5-1):	DIAZED fuse insert: utilisation category gL / gG: 10 A TDz, 16 A Dz for safety applications only fuse to EN IEC 60269-1 gL / gG: 10 A Automatic fuse: cable protection switch C-feature to IEC 60898 (VDE 0641): 10 A

Rated voltage:	Switching element: 300 VAC Lamp fitting Ba9S: 125 VAC / 2.5 W Lamp fitting Wedge-Base W2 × 4.6 d: 60 VAC / 1 W Lamp fitting with integrated LED: 24 VAC/DC / 110 VAC / 230 VAC illuminated washer: 24 VAC/DC Continuous current: 10 A Switching capacity: A400, R300, A600 = identical polarity
Cable section:	Screw connection: single or multi-strand with conductor ferrules / DIN 46228 Parts 1, 3, 4: $2 \times 0.5 \dots 1.5 \text{ mm}^2$ / $2 \times \text{AWG } 20 \dots 16$ single- or multi-strand without conductor ferrules: $2 \times 1 \dots 1.5 \text{ mm}^2$ / $2 \times \text{AWG } 18 \dots 14$ Cage clamps: multi- or fine-strand with conductor ferrules DIN 46228 Parts 1, 3, 4: $2 \times 0.25 \dots 0.75 \text{ mm}^2$ / $2 \times \text{AWG } 24 \dots 18$ single-, multi- or fine-strand without conductor ferrules: $2 \times 0.25 \dots 1.5 \text{ mm}^2$ / $2 \times \text{AWG } 24 \dots 16$ Soldering terminals: $0.8 \times 0.8 \text{ mm}^2$ Connector for illuminated washer: fine-strand with conductor ferrules DIN 46228 Parts 1, 4: $1 \times 0.25 \dots 1.5 \text{ mm}^2$ / $2 \times \text{AWG } 24 \dots 16$ single- or multi-strand without conductor ferrules: $2 \times 0.14 \dots 1.5 \text{ mm}^2$ / $2 \times \text{AWG } 28 \dots 16$
Insulation of the cable:	Screw connection: 8 ... 10 mm Cage clamps: 7 ... 9 mm Connector for illuminated washer: 7 mm
Tightening torque:	of the screw of the metal support: 1.5 Nm of the screw of the plastic support: 1.0 Nm of the ground screw of the support: 1.0 Nm of the connecting screws: 0.8 Nm at the connector for the illuminated washer: 0.22 Nm
Suitable screwdrivers:	Slotted screwdriver: 5.5 mm × 1 mm idem (for support): 4.5 mm × 0.8 mm Philips screwdriver (Pozidrive profile): PZD 0, PZD 2 Torx screwdriver: T10 Slotted screwdriver (cage clamps): 3.5 mm × 0.5 mm

3.13 BWT sensor buttons (for fitting in Elan two-hand control panels of the SEPG 05.3..., SEPK 02.0... and SEP 09.0... type or as stand-alone variant)

BWT-SCA4-185Z-E	Sensor A incl. connecting cable: mounting diameter 45 ... 60 mm, diameter actuating surfaces 63 mm, 1 NO + 1 NC
BWT-SCB4-185Z-E	Sensor B, mounting diameter 45 ... 60 mm, diameter actuating surfaces 63 mm, 1 NO + 1 NC
BWT-LKW-SCA-2 bzw.-5	Cable socket with 2 or 5 m cable, black, for sensor A to connect sensor A to the SRB 201ZH-24VDC, M12, 5-pole, angled
BWT-LKW-SCB-2 bzw.-5	Cable socket with 2 or 5 m cable, black, for sensor B to connect sensor B to the SRB 201ZH-24VDC, M12, 5-pole, angled
BWT-1	consists of: BWT-SCA4-185Z-E, BWT-SCB4-185Z-E, BWT-LKW-SCA-2, BWT-LKW-SCB-2
BWT-2	consists of: BWT-SCA4-185Z-E, BWT-SCB4-185Z-E, BWT-LKW-SCA-5, BWT-LKW-SCB-5

General data:	
– Sensor principle:	capacitive static-dynamic
– Temperature range:	0 °C ... +55 °C
– Rated insulation voltage:	300 V
– Degree of pollution:	3
– Protection class::	IP 69K, Connector: IP67
– Enclosure material:	Polycarbonate (PC)
– Static discharge:	8 kV to EN 61000-4-3
– HF radiation:	10 V/m to EN 61000-4-3
– Fast transients:	2 kV/m to EN 61000-4-3
– HF conductance:	10 V to EN 61000-4-3
– RF suppression:	Class B to EN 55011
Input:	
– Operating voltage:	24 VDC ±10%
– Residual ripple:	max. 10%
– Power consumption:	< 65 mA
– Switching frequency:	1 Hz
– Sensing speed:	> 50 mm/s
Output:	
– Contact configuration:	1 NO contact / 1 NC contact
– Relay type:	PhotoMOS relay, electronic
– Minimum current:	> 10 mA each contact
– Switching capacity:	200 mA / 24 VDC each contact
– Reliability:	Semi-conductor level

3.14 Technical data safety-monitoring module SRB 201ZH

General data	
Standards:	IEC/EN 60204-1, EN 60947-5-1; EN ISO 13849-1, IEC/EN 61508
Climate resistance:	EN 60068-2-78
Fixation:	Snaps onto standard DIN rail to EN 60715
Terminal designations:	EN 60947-1
Material of the enclosure:	glass-fibre reinforced thermoplastic, ventilated
Material of the contacts:	AgSnO, self-cleaning, positive drive
Weight:	200 g
Start conditions:	Automatic
Feedback circuit (Y/N):	Yes
Pull-in delay for automatic start:	approx. 50 ms
Response time:	approx. 30 ms
Mechanical data	
Connection type:	Screw connection
Cable section:	min. 0,25 mm ² / max. 2,5 mm ²
Connecting cable:	rigid or flexible
Tightening torque for the terminals:	0.6 Nm
With removable terminals (Y/N):	Yes
Mechanical life:	10 million operations
Electrical life:	Derating curve available on request
Resistance to shock:	10 g / 11 ms
Resistance to vibrations to EN 60068-2-6:	10 ... 55 Hz, amplitude 0.35 mm
Ambient conditions	
Ambient temperature:	–25 °C ... +45 °C
Storage and transport temperature:	–40 °C ... +85 °C
Protection class:	Enclosure: IP40 Terminals: IP20 Wiring compartment: IP54
Air clearances and creepage distances to IEC/EN 60664-1:	4 kV/2 (basic insulation)
EMC rating:	to EMC Directive
Electrical data	
Contact resistance in new state:	max. 100 mΩ
Power consumption:	max. 1.2 W
Rated operating voltage U _e :	24 VDC –15%/+10%, residual ripple max. 10%

Max. fuse rating of the operating voltage:	Internal electronic fuse: F1, F2: tripping current > 0,2 A F3: tripping current > 0,6 A
Monitored inputs	
Cross-wire detection (Y/N):	Yes
Wire breakage detection (Y/N):	Yes
Earth leakage detection (Y/N):	Yes
Number of NO contacts:	2
Number of NC contacts:	2
Cable lengths:	1.500 m with 1,5 mm ² 2.500 m with 2,5 mm ²
Conduction resistance:	max. 40 Ω
Outputs	
Number of safety contacts:	2
Number of auxiliary contacts:	1
Number of signalling outputs:	0
Switching capacity of the safety contacts:	13-14; 23-24: max. 250 V, 6 A ohmic (inductive in case of appropriate protective wiring); min. 10 V / 10 mA
Switching capacity of the auxiliary contacts:	31-32: 24 VDC / 2 A
Max. fuse rating of the safety contacts:	6 A slow blow
Recommended fuse for the auxiliary contacts:	2 A slow blow
Utilisation category to EN 60947-5-1:	AC-15 / DC-13: EN 60947-5-1:2007
Dimensions H x W x D:	100 mm x 22.5 mm x 121 mm

The data specified in this manual are applicable when the component is operated with rated operating voltage U_e ±0%.

4 Classification

4.1 Safety classification

B _{10d} :	NC-contact: 20.000.000* NO-contact: 1.000.000** NO-contact: 100.000*** Siemens emergency stop actuator: refer to SN31920 monitored Siemens switching element: 1 x 10 ⁵
Service life:	x years
to EN ISO 13849-1:	up to PL x
to IEC/EN 61508:	up to SIL x: PFH < 2,0 x 10 ⁻⁸
to EN 954-1:	up to Category x

* load independent
** 1,000,000 (in case of ohmic or near-ohmic load and overdimensioning, i.e. ≤ 10 % of the nominal load)
*** 100,000 (in case of inductive load and overdimensioning (≤ 10 % of the nominal load))

Note: in combination with SRB two-hand modules, the restrictions * to *** are not applicable or covered through the safety-monitoring module.

$$MTTF_d = \frac{B_{10d}}{0,1 \times n_{op}} \quad n_{op} = \frac{d_{op} \times h_{op} \times 3600 \text{ s/h}}{t_{cycle}}$$

4.2 Safety classification of the SRB 201 ZH safety-monitoring module

Standards:	EN ISO 13849-1, IEC 61508, EN 60947-5-1, DIN EN 574, EN 60204-1
PL:	Stop 0: up to e
Control category:	Stop 0: up to 4
DC: Stop 0:	Stop 0: 99% (high)
CCF:	> 65 points
SIL:	Stop 0: up to 3
Service life:	20 years
B _{10d} value (for one channel):	Small load range 20%: 20,000,000 40%: 7,500,000 60%: 2,500,000 80%: 1,000,000 Maximum load 100%: 400,000

$$MTTF_d = \frac{B_{10d}}{0,1 \times n_{op}} \quad n_{op} = \frac{d_{op} \times h_{op} \times 3600 \text{ s/h}}{t_{cycle}}$$

For an average annual demand rate of $n_{op} = 126,720$ cycles per year, Performance Level PL e can be obtained at maximum load.

n_{op} = average number of activations per year
 d_{op} = average number of operating days per year
 h_{op} = average number of operating hours per day
 t_{cycle} = average demand rate of the safety function in s
 (e.g. 4 × per hour = 1 × per 15 min. = 900 s)

(Specifications can vary depending on the application-specific parameters h_{op} , d_{op} and t_{cycle} as well as the load.)

4.3 Safety classification of EDRR..., KDRR..., ADRR 40, EDRZ... emergency stop command devices

Standards	EN ISO 13849-1
B _{10d} (NC contact):	100,000
Service life	20 years

$$MTTF_d = \frac{B_{10d}}{0,1 \times n_{op}} \quad n_{op} = \frac{d_{op} \times h_{op} \times 3600 \text{ s/h}}{t_{cycle}}$$

5 Mounting

5.1 Mounting instructions for two-hand control panels

Required space

for e.g. installation, checking, maintenance, etc.: refer to the supply tables according to the Elan list ZHS/08 (maintenance of the components is not required).

Fixing

Non-portable two-hand control panels:

- Individual panels: rearside (with mounting holes) horizontally
- Panels with stands: floor mounting (with mounting holes for floor mounting)
- Control elements: at least 830 mm over the access area
- When a rotating mechanism is used, the lower safety distance in no way must be exceeded.
- The panels must be fixed so that they cannot be removed by simple means.

Portable two-hand controls:

- Authorised for the versions STP01.4..., STP01.5..., STP02.4..., STPSK..., FES01.4..., FBES01.4... and FBES02.4...
- In two-hand control panels with plug-in cables, no emergency stop command devices must be integrated to DIN EN 692 and DIN EN 693.
- According to SUVA (CH), a lateral protection must be additionally provided at the outer covers of movable panels if necessary, if the required approach speeds cannot be observed. If the possibility exists that the operator can access the press chamber or similar with

the movable panel, this situation must be prevented by means of an accordingly determined access cable length or by a suitable spacer at the stand or similar mechanical features.

- A relocation of the operating unit (two-hand control panel and stand) up to the hazardous point or area must be limited by the user. This can be realised for instance by means of a suitable spacer, which is welded to the stand (refer to DIN EN 574).

Identification plate

- The identification plate does not include all specifications mentioned sub n° 11 of DIN EN 574. Specifications regarding the type and the response time generally must be made by the user, as these specifications generally cannot be realised upon the delivery of a stand-alone two-hand control panel (i.e. without the corresponding circuit).
- When mechanical pushbuttons with a max. diameter of 55 mm are fitted, the two-hand control panels meet the requirements of DIN EN 574 regarding tampering by hand, elbows and legs.

Plastic two-hand control panels type SEPK02.0...

Plastic two-hand control panels of the type SEPK02.0... are suitable for temperature ranges from -25 to +60°C. At temperatures < -5/-10°C a specific reduction of the shock resistance of the material must be observed. If temperatures of > +60°C can be expected in hot areas, the use of metal two-hand control panels (refer to List ZHS/08) is recommended.

5.2 General mounting instructions for control elements

- Control elements must be selected, designed and installed so that they can provide for an ergonomic operation.
- For ergonomic reasons, the actuating surface of a control element / pushbutton should have a diameter of at least 40 mm and for safety reasons of 55 mm at the most.
- Control elements must not be red and must not build crushing or shearing points with their environment.
- Foreseeable forces, triggered by the acceleration of a two-hand control panel, must not generate an output signal (e.g. by falling, unexpected shock, impact load, etc.)
- According to EN 574, the switching elements of type III C control elements must have a "1 NC/1 NO" contact configuration. It is recommended to realise the NC and NO contacts in two switching elements, which are independent from each other, for each control element/signal converter. As the occurring actuating forces are regarded, it furthermore is recommended to equip the individual control elements with max. two switching elements.
- Other particularities: see Elan List ZHS/08.

5.3 Mounting instructions for ADP... type control elements (ordering suffix E1 or E2) and ADRR40 type emergency stop command devices

General:

- The ADP... type pushbuttons are by default suitable for mounting up to a wall thickness of max. 4 mm (increased wall thickness possible with modified thread ring). The maximum tightening torque for the device head to tighten the thread ring with an A-14 tool is 1 Nm.
- The supplied EDT-12 double-sided adhesive gasket must be adhered under the device head prior to the disassembly of the device (to adjust and secure the pushbutton). The protective films of the gasket must be previously removed.

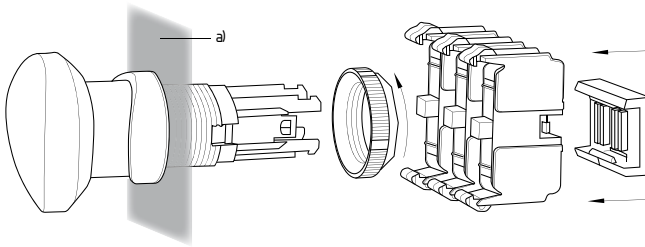

Fig. 1: a) Front plate

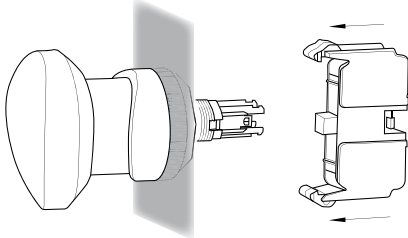

Fig. 2

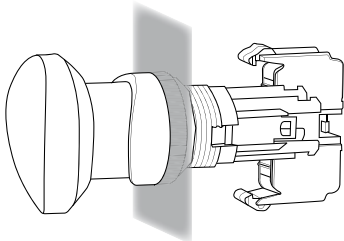

Fig. 3

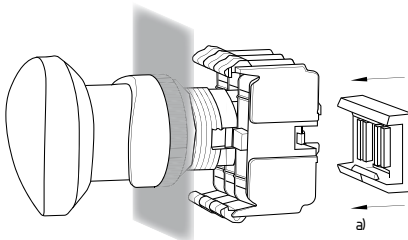

Fig. 4: a) Securing plate

5.4 Mounting instructions for EDRR EFR and KDRR EFR type emergency stop command devices

- Fit the EDR EFR emergency stop actuator in non-actuated condition by means of the ELM mounting flange, align and tighten (max. 0.6 Nm).
- Snap the EFR spring element in the middle position of the EFM mounting flange (position 3). The EFR spring element is supplied in tensioned condition.
- The EDR EFR actuator is latched, i.e. mechanically fixed, to the EFR spring element by actuation. By rotating to the right and consecutive pulling, the spring element is retensioned and the emergency stop command device is brought back to its basic position.
- Snap the EF contact element(s) into position(s) 1 (and/or 2) of the EFM mounting flange.
- EFR spring element: to avoid fitting errors, we recommend to fit the enclosed locking plate (A) by means of both locking rings (B) 4 mbo 09 after the contacts have been snapped on (see photo). No special tools are required. This locking plate ensure a proper fitting and fixation of the contact elements.

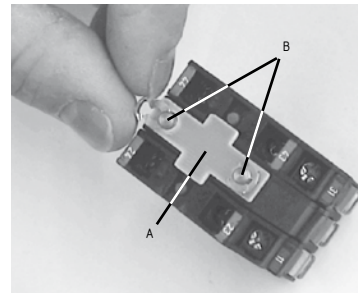

Fig. 5

- The emergency stop device is now ready for operation.

5.5 Mounting instructions for EDR type emergency stop command devices

- Fit the EDRZ emergency stop actuator in non-actuated condition by means of the EFM mounting flange, align and tighten (max. 0.6 Nm). Do not actuate the emergency stop actuator!
- Snap the EF contact element(s) into position(s) 1 (and/or 2 and 3) of the EFM mounting flange.
- The emergency stop device is now ready for operation.

5.6 Mounting instructions for BWT sensor button



In constructions for the assembly and putting into operation of BWT-1/BWT-2, the requirements of EN 574 must be imperatively observed!

Definition of "two-hand control panel"

A two-hand control panel requires a simultaneous actuation with both hands to start and maintain the operation of a machine, as long as there are risks. A two-hand control panel must be located outside the hazardous area, to prevent the operator from entering this area before the machine has come to a complete standstill.

Avoiding inadvertent actuation and tampering (also refer to EN 574)

In accordance with the risk analysis for the individual application, the BWT of a two-hand control panel must be arranged so that the protective function of the two-hand control panel cannot be tampered by simple means and that the probability of any inadvertent actuation is as low as possible. The utilisation of one hand, possible combinations of one hand and/or other body parts and/or the use of simple tools enabling tampering, must be accounted for in order to avoid access to the hazardous area as long as a hazardous situation exists. Inadvertent actuation (e.g. by the clothes of the operator) must be likely accounted for. Partitioning walls must be installed between the BWT, which are so arranged behind the operating side and the rearside that they cannot be actuated from the operating side by means of the top of a test cone representing the elbow.



The arbitrary installation (without operating panel) of BWT must be avoided, to prevent them from being triggered by falling objects etc.

Enclosure mounting of BWT (also refer to EN 574)

The enclosure and the fixing possibilities must be designed so that they withstand the operating the foreseeable working loads.

Selection, design and installation of BWT (also refer to EN 574)

The BWT must be so installed that they do not cause human exhaustion (e.g. as a result of unhandily positioning or insuitable movements).

Inadvertent starting of mobile and portable hand-held machines (also refer to EN 574)

A two-hand control panel must be so designed that any inadvertent actuation as a result of the normal handling of the mobile and/or portable hand-held machines, which it controls, is prevented.

Mobile two-hand control panels (also refer to EN 574)

The enclosure, in which a two-hand control panel is installed, must be steady under normal circumstances. Mobile two-hand control panels must be equipped with features, which prevent a relocation during the actuation.

Safety distance (also refer to EN 574)

The safety distance between the BWT and the hazardous point must be so large, that when the BWT is released, the hazardous point can only be reached after the hazardous movement has come to standstill.



The safety distance "S" in mm is calculated using the following formula: $S = V \times T + C$

Legend:

V = Gripping speed = 1,600 mm/s

T = Run-on time in seconds

C = Additional value = 250 mm

If access to the hazardous area is safely prevented upon actuation of the BWT, e.g. by a protective cover of the BWT, the additional value C can be taken equal to 0. The minimum safety distance anyhow must be 100 mm.

Safety rules for BWT sensor buttons

- In constructions for the assembly and putting into operation of BWT sensor buttons (A + B), the requirements of EN 574 must be imperatively observed!
- In accordance with the risk analysis for the individual application, the BWT sensor buttons of a two-hand control panel must be arranged so that the protective function of the two-hand control panel cannot be tampered by simple means and that the probability of any inadvertent actuation is as low as possible. Avoiding inadvertent actuation and tampering (see figure).
- The arbitrary installation (without operating panel) of BWT sensor buttons A + B must be avoided, to prevent them from being triggered by falling objects etc.

Installation instructions: I

- The two-hand relay SRB-201ZH 24VDC must only be wired as shown in the wiring examples. Any parallel- or series-wiring of the relay contacts of the BWT sensor buttons neutralises the safe function of the devices. The downstream contactors or relays must be equipped with positive-guided contacts and monitored in the feedback circuit.
- To trigger a hazardous movement, two sensors "BWT-...A and BWT-...B" must be used. An output signal is generated, when both sensors are actuated within a timeframe smaller than or equal to 0.5 sec. The sensors must be procured and arranged so their disabling by simple means or inadvertent actuation is prevented.
- The use of BWT sensors in the enclosures of two-hand control panels still is a problem at this time, as currently no defined test method exists regarding the installation of the sensors in respect of protection against tampering with the knees or the elbows.
- The measuring cone provided for this test, which at the time that the standards were drafted was only aligned to control elements with mechanical operating principle, should cause the triggering of the sensors in case of a non-appropriate installation.
- The sensors however function capacitively in conjunction with the human hand. A suitable material for a measuring cone, which could influence the sensors, is not known. The measuring cone furthermore insufficiently takes into account that sensors can be smoother actuated with different body parts and therefore can be smoother tampered as well.
- For the use of sensors, the measuring cone should be adapted during a review of the standards. The two-hand control panels of the type SEPG05.3..., SEPK02.0... and SEP09.0... therefore are not BG-tested in combination with the BWT sensors. If these sensors are used despite that, either the minimum distance from the closest control element with regard to the hazardous area must be calculated by means of the equation

$$S = (K \times T) + C$$

$$K = 1,600 \text{ mm/s}, C = 250 \text{ mm}$$

or a manual tampering by means of a combination of one hand and other body parts or using simple tools must be prevented.

- Note: additional information can be found in our list ZHS/08 and DIN EN 574.

Installation instructions: II

The relay must only be wired as shown in the wiring examples. Any parallel- or series-wiring of the BWT relay contacts neutralises the safe function of the devices. The downstream contactors or relays must be equipped with positive-guided contacts and monitored in the feedback circuit.

To trigger a hazardous movement, all sensors of the BWT must be used. An output signal is generated, when both sensors are actuated within a timeframe smaller than or equal to 0.5 s. The sensors must be procured and arranged so their disabling by simple means or inadvertent actuation is prevented.

The distance between the sensors can be reduced, when one or more partitioning walls are installed to prevent that the sensors are reached with the extremities of a 260 mm long wire, representing the hand span. The sensors must be arranged on a horizontal or nearly horizontal surface with a distance of at least 1,100 mm to the floor or the access area. This distance must be observed, when it is ensured by suitable protective measures that no other body part (e.g. knee, hip) can trigger an actuation in combination with one hand.

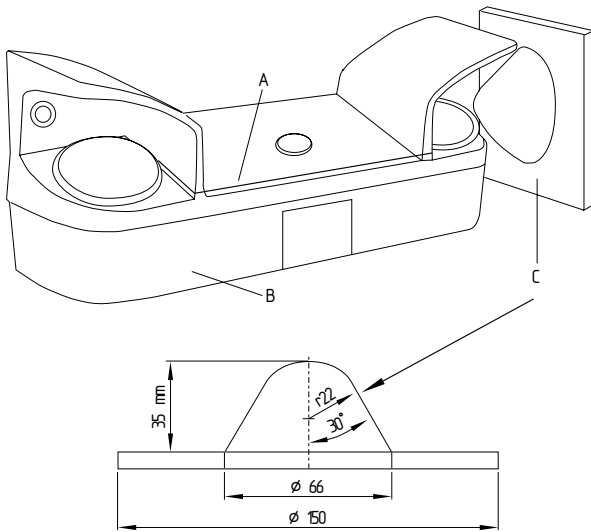

Fig. 6: A = wire length: ≥ 260 mm; B = two-hand control panel; C = test cone (elbows) to EN 574

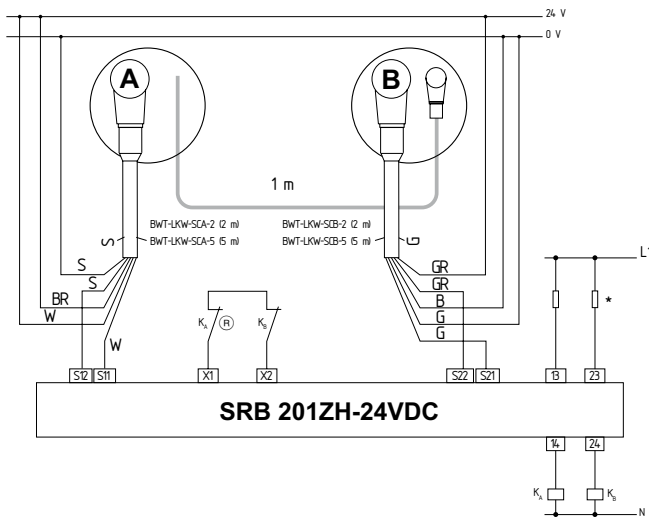

Fig. 7: Switching diagram: A = BWT sensor button A; B = BWT sensor button B; 1 m = function safety cable 1 m; S = black; BR = brown; W = white; GR = grey; B = blue; G = yellow; SRB 201ZH-24VDC = two-hand safety relay, safety level Type III C to EN 574, control category 4 to EN 954-1; * = recommended fuse for the enabling contacts: 6 A slow blow

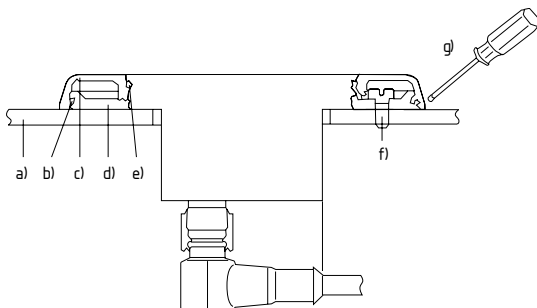

Fig. 8: a) Mounting surface; b) O-ring; c) Cover ring; d) Flat gasket; e) O-ring; f) 3 \times fixing screws; g) Cover ring can be removed with screwdriver

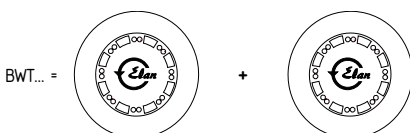

Fig. 9: BWT... = BWT-SCA4-185Z-E + BWT-SCB4-185Z-e

Special installation and mounting instructions for control elements of the BWT (sensor button) type for the two-hand control panels of the type SEPG05.3..., SEPK02.0... and SEP 09.0.

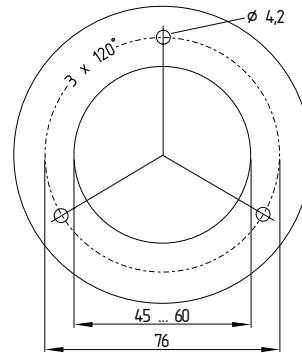

Fig. 10

5.7 Mounting instructions for the Siemens SIRIUS 3SB3 emergency stop actuator

For assembling and disassembling the products of the SIRIUS range, no special tool is required. For the disassembly of the cover plates of all actuating elements and signalling devices in metal or signalling devices in moulding material, the 3SB3921-0BC mounting tool is required.

Observe the head diameter of 32 mm, 40 mm or 60 mm! In case of an illuminated washer, observe the outer diameter of 60 mm!

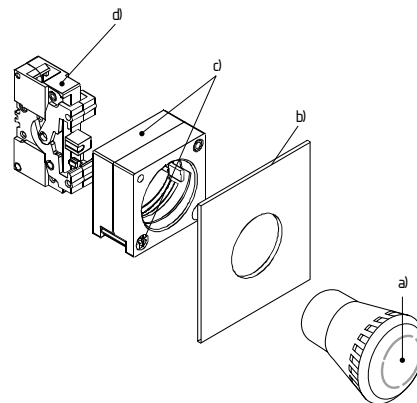

Fig. 11: Front plate mounting, front plate thickness 1 ... 6 mm; a) Actuator; b) Label; c) Label carrier; d) Front plate; e) Support with fixing screw; f) Switching element

Assembly of the support (see Fig. 2)

The support for round actuating elements can be used for two ranges of front plate thickness. Upon delivery, the support is set to the thickness 1 ... 4 mm (Fig. 2 left) and is positioned from the rear side onto the actuator in the arrow direction "1 – 4 mm". The fixing screw is located at the bottom right

For front plate thicknesses of 3 ... 6 mm, the support is turned, so that the support is fitted in the arrow direction "3 – 6 mm". In this case, the fixing screw must be turned counterclockwise up to the end stop before the support is installed (Fig. 2 right).

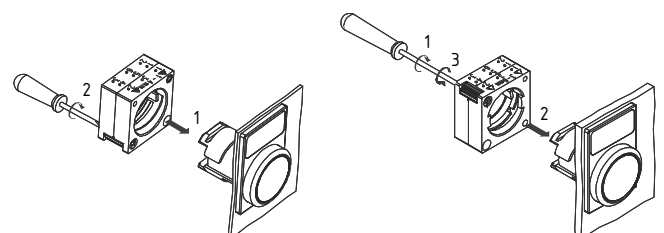

Fig. 12

If plate carriers, protective caps or similar accessories are used, the maximum admissible front plate thickness must be reduced by the plate thickness of the accessory.

Mounting the switching elements

The element is placed onto the actuator from the rearside and snapped onto the rearside by pressure (Fig. 3). When no accessories are used, a maximum of two switching elements can be fitted.

If three elements and one/two switching element(s) are required, the support must be placed onto the actuator before the elements are snapped on.

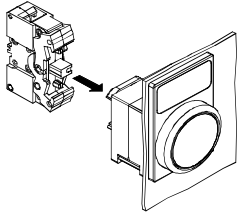

Fig. 13



Note: For emergency stop devices equipped with 1 or 2 switching elements in combination with carrier 3SB3901-0AB, one switching element must be mounted in central position!

5.8 Mounting instructions for the SRB 201ZH safety-monitoring module

Mounting: snaps onto standard DIN rails to EN 60715.

Snap the bottom of the enclosure slightly tilted forwards in the DIN rail and push up until it latches in position.

Dimensions

All measurements in mm.

Device dimensions (H/W/D):

100 (120 with plugged-in terminals) × 22.5 × 121 mm

6 Electrical connection

6.1 General information for electrical connection

Required features for the machine control

Required features for the machine control (including safety level)/connections between the two-hand control panel and the machine control: refer to the relevant safety, professional or product standards (C-standards), e.g.:

- DIN EN 692 – Mechanical presses,
- prEN 693 – Hydraulic presses,
- EN 201 – Injection moulding machines for rubber and plastic,
- prEN 1010 – Printing machines and paper processing machines,
- otherwise refer to EN 954-1.

Size and type of the feed and connecting cables

- Cables only may be fed into the two-hand control panel through the rear or the bottom.
- Cables must be equipped with water-tight cable glands with strain-relief feature and protection against buckling.
- Connection of the protective ground wire in two-hand control panels: to DIN EN 60204-1, every protective ground wire must be connected individually during wiring.
- According to the harmonised standards, no protective ground wire distribution must be realised through the available ground bolt. For each earth bolt, only one protective ground wire connection is authorised.

- If multiple protective ground wires are connected, e.g. by feeding multiple cables into the enclosure, a commercially available earth terminal with the required number of terminals must be installed in the enclosure and connected to the protective ground wire connection (one PE terminal for each protective ground wire). The cable length for the cable connections must be sufficient, in order to provide for sufficient convenience of handling during fitting or possible repairs.
- Inside the enclosure, outward insulated terminals must be provided, if the protective ground wire should be "looped through".
- Otherwise refer to EN 60204: electrical equipment of machinery

Safety distance

- For the calculation of the required safety distance between the control elements and the hazardous area, the following formula of prEN 999 shall be applied:

$$S = K \times T (+ C)$$

- S = Minimum safety distance in millimetres, measured from the hazardous area to the detection point, the detection line or the protected field
- K = constant in mm per second = (usually) 1,600 mm/s
- T = total response time in seconds; consists of t1 and t2:
- t1 = maximum response time of the safety device between the (physical) triggering of the perceptive element (releasing the control element) and the time, at which the safety device has switched the output signal to the "OFF" state (this information is provided by the manufacturer of the "signal processing" module).
- t2 = maximum response time of the machine, i.e. the time required to shutdown the machine or to eliminate the risk, after the transmission of the output signal of the safety guard (this information is provided by the machine builder).
- C = additional distance in mm, based upon the intrusion into the hazardous area = 250 mm, however irrelevant for the Elan two-hand control panels*.

* If the risk of intrusion of the body or body parts into the hazardous area is prevented during the actuation of the two-hand control panel, e.g. by adequate covering, C can be equal to 0 mm with an admissible minimum distance for S = 100 mm (quote from EN 999).

6.2 Additions/notes for plastic two-hand control panels of the type SEPK02.0...

Assembly of control elements, emergency stop command devices and additional signalling and command devices

Only "fully insulated" command and signalling devices must be used.

Size and type of the feed and connecting cables/cable connections

Basically only plastic cable glands with sufficient strain-relief for the cable may be used.

Grounding for SEPK02.0... without stand

In case of normal wall-mounting, SEPK02.0... is fully insulated and therefore does not require any protective ground wire connection.

Stand assembly/grounding

If the SEPK02.0... is fitted onto an Elan stand of the STP..., STPSK..., FES..., FBES... type or other versions of stands (e.g. selfmade solutions), no "conducting" connections may be created inside the panel. The grounding bolts on the ZPL-1 intermediate plate must be removed by the user. The stand must be individually grounded by the user, if the cable is fed through the stand tube. On request, the ZPL-1 intermediate plate can be realised without grounding bolt in factory without additional charges (= ZPLK-1) (default, when the panel and the stand are supplied by Elan in fitted condition). If the connecting cables are not fed through the stand tube, the individual protective ground wire connection on the stand can be omitted.

The STPLC...type stand from Elan is equipped with a protective ground wire connection on the upper flange plate, which the user must connect with the protective ground wire system when the cable is fed through the stand tube.

6.3 Additions/notes for die-cast aluminium (AL-226) two-hand control panels of the type SEPG05.3...

Stand assembly/grounding

- If the SEPG05.3... is fitted onto an Elan stand of the STP..., STPSK..., FES..., FBES... type or other versions of stands (e.g. selfmade solutions), the outer two ground bolts on the ZPL intermediate plate must be removed by the user.
- If the panel and the stand are ordered or supplied in fitted condition (without additional charges), this step does not apply.
- At the positions provided to that effect, the user must establish a protective ground wire connection between the upper part of the SEPG05.3 enclosure and the corresponding bottom part of the enclosure.
- Any further information can be found in the Elan list ZHS/08.

6.4 Special wiring instructions for the STP02... stand

When realising the wiring through the square tube of STP02... type stands, please observe that only non-hazardous voltages may be realised. If necessary, an additional ground connection of the stand base must be provided by the user, whereby "tripping hazards", created due to the presence of the additionally installed ground wire, must be prevented.

6.5 Electrical connection of the SRB 201ZH safety-monitoring module



The electrical connection may only be carried out by authorised personnel in a de-energised condition.

Wiring examples: see appendix

7 Operating principle and settings

7.1 Operating principle and settings SRB 201ZH safety-monitoring module

LED functions

- K1: Status channel 1
- K2: Status channel 2

Description of the terminals

Voltages:	A1	+24 VDC/24 VAC
	A1.1	+ 24 V
	A2	0 VDC/24 VAC
	A2.1	0 V
Inputs:	S11	Input channel 1 (+)
	S12	Input channel 1 (-)
	S21	Input channel 2 (-)
	S22	Input channel 2 (+)
Outputs:	13-14	First safety enabling circuit
	23-24	Second safety enabling circuit
Start:	X1-X2	Feedback circuit
	31-32	Auxiliary NC contact

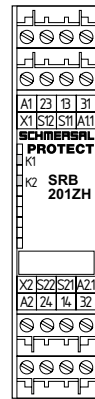

Fig. 14

Notes



The NC contact of the buttons A + B must be opened, before the NO contact closes. No overlapping contacts to avoid triggering of the fuses F1 and F2.



The pushbuttons A + B must be actuated within a timeframe of < 0.5 sec (simultaneous operation monitoring), otherwise no start enabling signal is given!

8 Dimensions

8.1 Dimensions of the two-hand control panel SEPK02.0

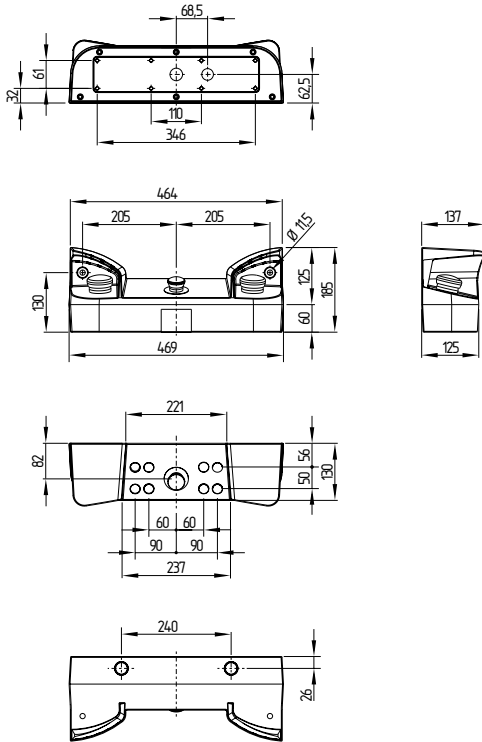

Fig. 15: each time 2 × M25 × 1.5 "knockout" holes for cable glands at the bottom and at the rear

8.2 Dimensions of the two-hand control panel SEPG 05.3

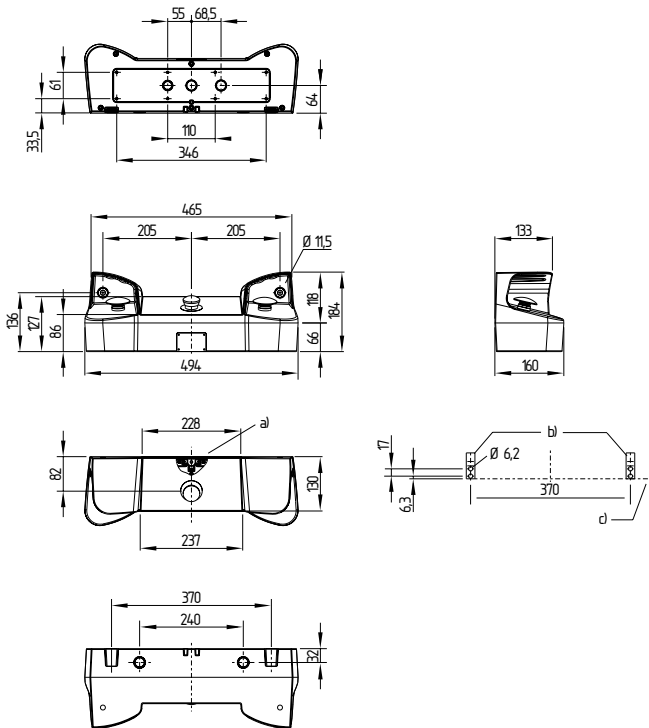

Fig. 16: each time 2 × M25 × 1.5 "knockout" holes for cable glands at the bottom and at the rear (thread length of the cable glands at least 10 mm). a) 3 × ground connection; b) Mounting of the mounting angle for panel bottom (rearside); c) Base SEPG05.2... panel

8.3 Dimensions of the two-hand control panel SEP01.0

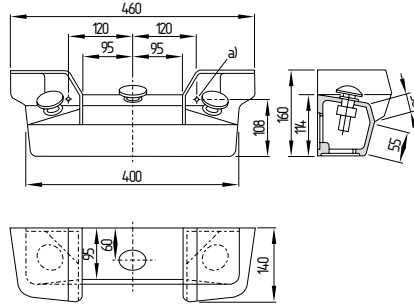

Fig. 17: a) mounting hole Ø 11.5

8.4 Dimensions of the two-hand control panel SEP01.4

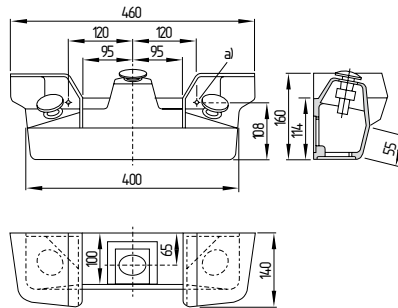

Fig. 18: a) mounting hole Ø 11.5

8.5 Dimensions of the two-hand control panel SEPLC05.2

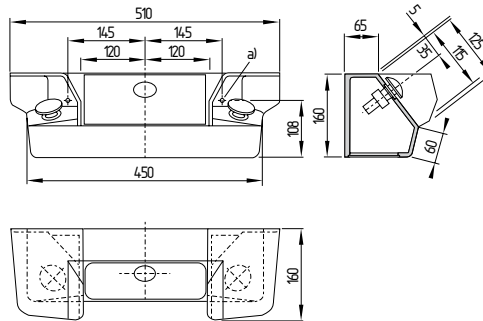

Fig. 19: a) mounting hole Ø 11.5

8.6 Dimensions of the two-hand control panel SEP07.0

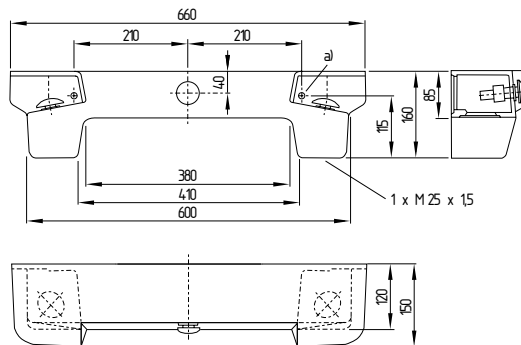

Fig. 20: a) mounting hole Ø 13.5

8.7 Dimensions of the two-hand control panel SEP09.0

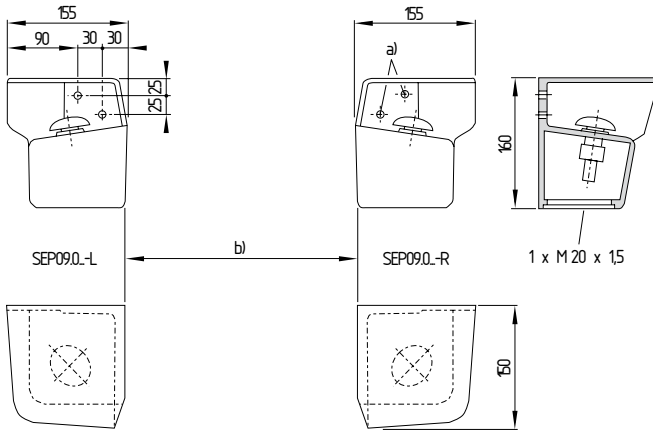

Fig. 21: a) Mounting holes \varnothing 11.5; b) Distance to be defined by the user to EN 574!

8.8 Dimensions of the EDRR and KDRR emergency stop command device

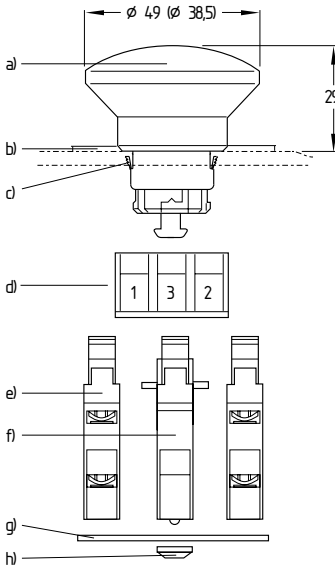

Fig. 22: a) EDR emergency stop actuator; b) Emergency stop label; c) Clamping element; d) Mounting flange ELM; e) 2 x contact element EF (Pos. 1 + 2); f) 1 x spring element EFR (middle, Pos. 3); g) Fuse board; h) Retaining rings 4 mbo 09

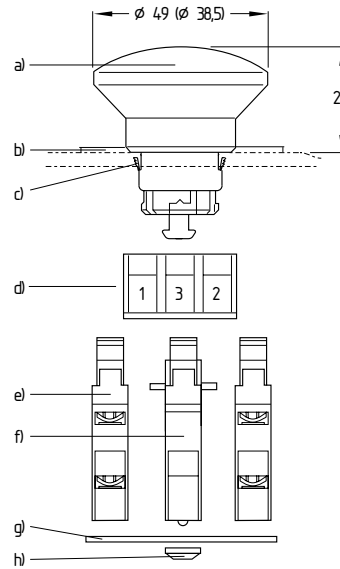

Fig. 23: a) KDR emergency stop actuator; b) Emergency stop label; c) Clamping element; d) Mounting flange ELM; e) 2 x contact element EF (Pos. 1 + 2); f) 1 x spring element EFR (middle, Pos. 3); g) Fuse board; h) Retaining rings 4 mbo 09

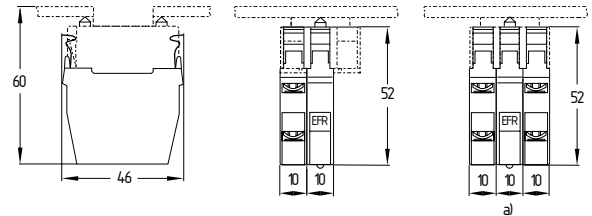

Fig. 24: a) Maximum number of contacts (2 contact elements, max. 4 contacts)

8.9 Dimensions of the ADR 40 emergency stop command device

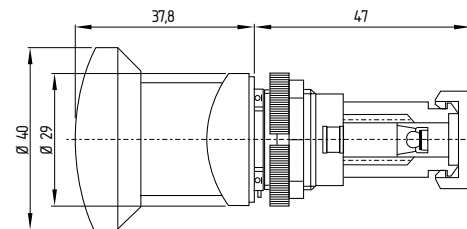

Fig. 25

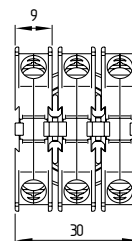

Fig. 26: Dimensions of the contact elements in fitted condition

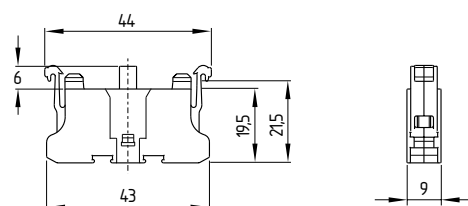

Fig. 27: Dimensions of the RF... contact elements

8.10 Dimensions of the EDRZ emergency stop command device

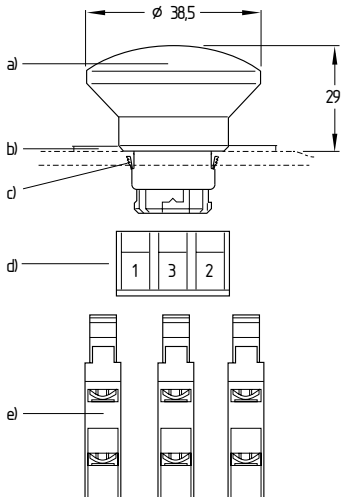

Fig. 28: a) EDRZ. emergency stop actuator; b) Emergency stop label; c) Clamping element; d) Mounting flange EFM; e) 3 × contact element EF

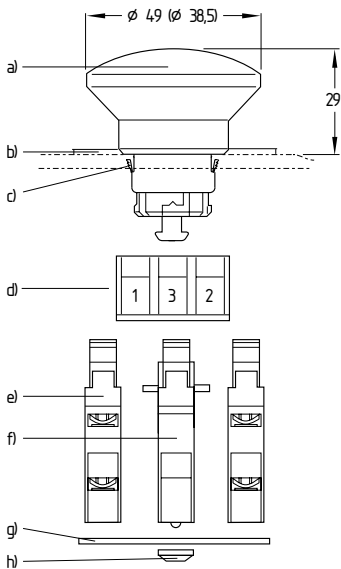

Fig. 29: a) EDR. emergency stop actuator; b) Emergency stop label; c) Clamping element; d) Mounting flange ELM; e) 2 × contact element EF (Pos. 1 + 2); f) 1 × spring element EFR (middle, Pos. 3); g) Fuse board; h) Retaining rings 4 mbo 09

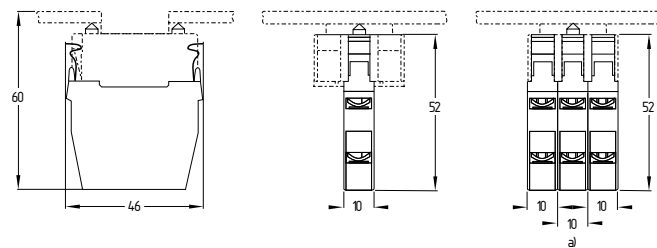

Fig. 30: a) Maximum number of contacts: 1 × EF 303 + 1 × EF 220 or 2 × EF 303 or 3 × EFK 1-pole

8.11 Dimensions of the sensor button BWT

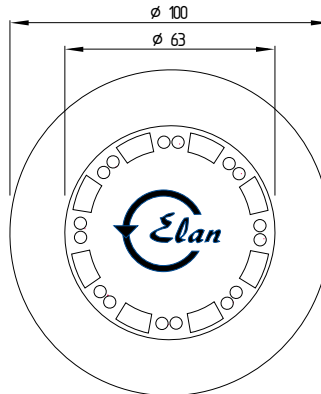

Fig. 31

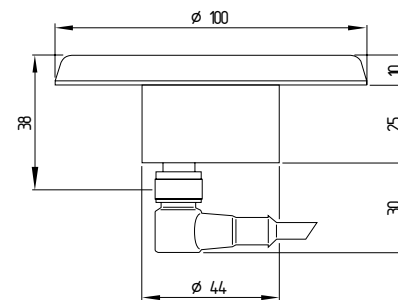

Fig. 32

8.12 Dimensions of the command devices/push buttons Siemens SIRIUS 3SB3

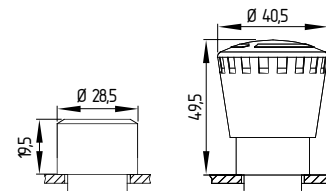

Fig. 33

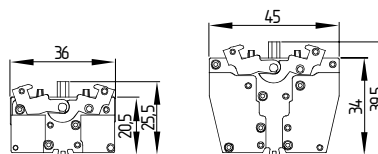

Fig. 34

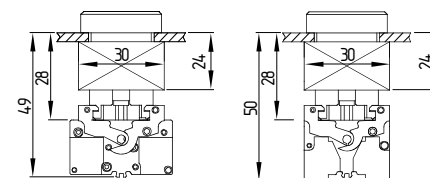

Fig. 35

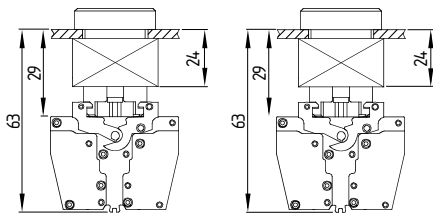

Fig. 36

9 Electrical connection

9.1 Electrical connection of EDR, EFR, KDRR EFR and EDRZ emergency stop command devices

Important notes



The electrical connection may only be carried out by authorised personnel in a de-energised condition. At least one contact with positive break must be integrated in the safety circuit.

After wiring, the contact elements must be cleaned (i.e. remove excess cables etc.).

The fixing screws of the contact element must be tightened with 0.8 Nm tightening torque.

Contact variants

The following contact combinations may be used:

- Screw or plug-in terminals:
 - 1 × EF 303 (1 NC/1 NO contact) + 1 × EF 220 (2 NC contacts) or
 - 2 × EF 303 (1 NC/1 NO contact) or
- EFK cage clamp: contact data upon request

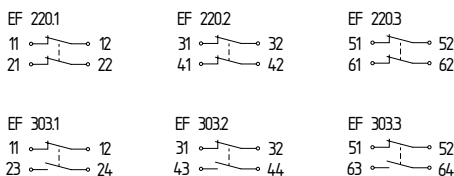

Fig. 37

Switch travel



Fig. 38: EF 303.1/2/3

EF 220.1/2/3

9.2 Electrical connection of ADRR 40 emergency stop command devices

Important notes



The electrical connection may only be carried out by authorised personnel in a de-energised condition. At least one contact with positive break must be integrated in the safety circuit.

After wiring, the contact elements must be cleaned (i.e. remove excess cables etc.).

The fixing screws of the contact element must be tightened with 0.8 Nm tightening torque.

Contact variants

- RF 02: 1 NO element
- RF 10: 1 NC element

9.3 Important notes for the 3SB3 Siemens SIRIUS emergency stop command device



Warning: For voltages exceeding the safety low voltage, a protective ground connection is required!

In case of mounting in front plates/enclosures in non-conducting material (Fig. 39)

Grounding of each individual actuator required, ground bolt available as accessory

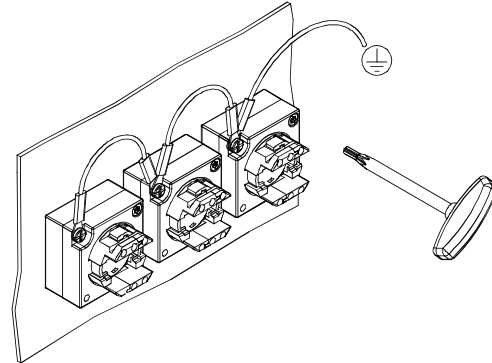

Fig. 39

In case of mounting in front plates in electrically conducting material

Due to its extended point, the flush mounted retaining screw (TORX T10) provides for both an anti-rotation protection and a bonding with the front plate. For surfaces with a thick layer of paint, the screw can be tightened further (approx. 0.5 rotation) to enhance the bonding and the anti-rotation protection. The efficiency of the protective measure must be checked by the owner.



Note: No liability shall be accepted for damages or injuries caused by an inappropriate handling or incorrect disassembly beyond the accordingly intended opening. Any inappropriate and incorrect handling can cause severe bodily injuries!

10 Set-up and maintenance

10.1 Set-up and maintenance of the two-hand control panels

Functional testing

The safety function of the two-hand control panel must be tested. The following conditions must be checked and met:

- Correct fixing of the fitted component
- Check the integrity of the cable entry and connections
- Check the two-hand control panels enclosure for damages

Maintenance

The function (switching) of the two-hand control panel must be tested in regular intervals.

Damaged or defective components must be replaced.

10.2 Putting into operation and maintenance EDR + EFR, KDRR + EFR, ADRR 40 and EDRZ emergency stop command devices

Functional testing

The safety function of the safety components must be tested. The following conditions must be checked and met:

- Correct fixing of the fitted component
- Check the integrity of the cable entry and connections
- Check the emergency stop command device for damage.

Maintenance

A regular visual inspection and functional test, including the following steps, is recommended:

- Check the correct fixing of the emergency stop command device and the contact element
- Remove particles of dust and soiling
- Check cable arrangement and connections

Damaged or defective components must be replaced.

10.3 Set-up and maintenance safety-monitoring module SRB 201ZH

Functional testing

The safety function of the safety-monitoring module must be tested. The following conditions must be previously checked and met:

1. Correct fixing
2. Check the integrity of the cable entry and connections
3. Check the safety-monitoring module's enclosure for damage.
4. Check the electrical function of the connected sensors and their influence on the safety-monitoring module and the downstream actuators

Maintenance

A regular visual inspection and functional test, including the following steps, is recommended:

1. Check the correct fixing of the safety-monitoring module
2. Check the cable for damages
3. Check electrical function

Damaged or defective components must be replaced.

11 Disassembly and disposal

11.1 Disassembly of EDP... (ordering suffix E1 or E2) type control elements and ADRR 40 emergency stop command devices

Disassembly

The safety switchgear must be disassembled in a de-energised condition only.

- Remove the wiring from the contact elements.
- Remove the red securing plate by "engaging" the fixing lugs.

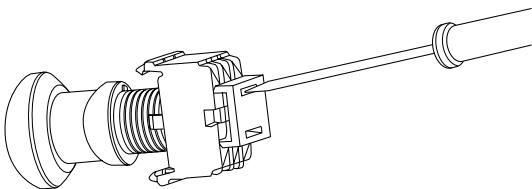

Fig. 40

- Disassembly of the contact elements: to this effect, a small screwdriver is inserted between the contact element and the dovetail. The contact element is removed towards the back by leverage action.

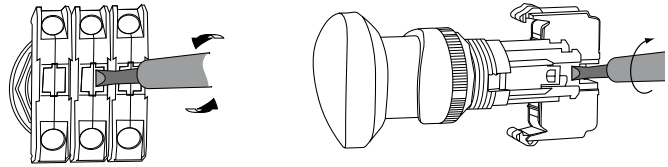

Fig. 41

- After disassembly of all contacts, the fixing nut can be removed by simply turning. After that, the device head can be removed.

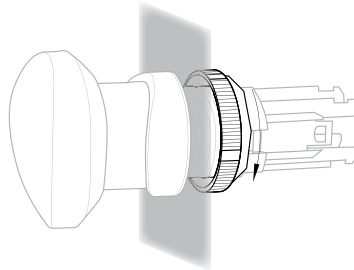

Fig. 42

11.2 Disassembly and disposal of the EDR + EFR, KDRR + EFR emergency stop command device

Disassembly

The safety switchgear must be disassembled in a de-energised condition only.

- Disassembly of the EF... contact element(s)
- Actuate/snap emergency stop actuator and turn
- Spread the spring (A) between actuator plunger and the EFR spring element by means of a screwdriver (B) or similar (refer to drawing Fig. 43). The actuator jumps back into basic position.
- Snap off the EFR spring element, disassembly the actuating head if necessary.

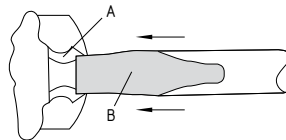

Fig. 43

Disposal

The safety switchgear must be disposed of in an appropriate manner in accordance with the national prescriptions and legislations.

11.3 Disassembly and disposal of the EDRZ emergency stop command device

Disassembly

The safety switchgear must be disassembled in a de-energised condition only.

- Disassembly of the EF... contact element(s)
- Loosen both fixing screws of the EFM flange - the mounting flange can be removed. This also applies to the emergency stop actuator.

Disposal

The safety switchgear must be disposed of in an appropriate manner in accordance with the national prescriptions and legislations.

11.4 Disassembly of the Siemens SIRIUS emergency stop command devices, here: disassembly of the elements

To disassemble the elements, press with a screwdriver on the knee joint of the element (Fig. 44).

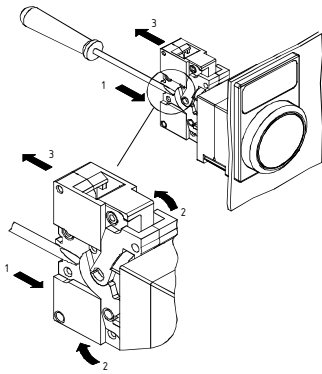

Fig. 44

Disposal

The two-hand control panel must be disposed of in an appropriate manner in accordance with the national prescriptions and legislations.

11.5 Disassembly and disposal of the safety-monitoring module SRB 210ZH

Disassembly

The safety-monitoring module must be disassembled in a de-energised condition only.

Disposal

The safety-monitoring module must be disposed of in an appropriate manner in accordance with the national prescriptions and legislations.

12 Appendix

12.1 Wiring example safety monitoring module SRB 210ZH

Dual-channel control with two pushbuttons A and B (see Fig. 45)

- Relay outputs: Suitable for 2-channel control, for increase in capacity or number of contacts by means of contactors or relays with positive-guided contacts.

⊕ = Feedback circuit

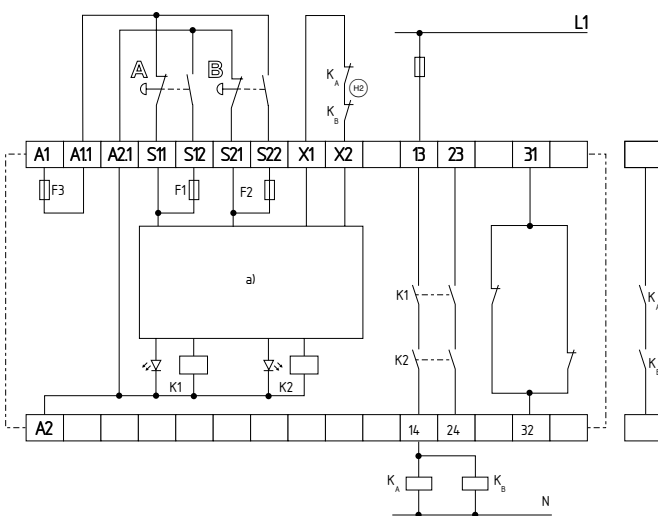

Fig. 45 a) Logic

Sensor configuration

6)

- Malfunctions of every contact as well as earth leakages and cross-wire shorts are detected.
- Feedback circuit ⊕: the feedback circuit is integrated as shown. The safety-technical function of external positive-guided contactors is monitored by a series-wiring of the NC contacts with the terminals X1 and X2. In idle state, this circuit must be closed. If the feedback circuit is not required, establish a bridge.
- Safety category III/C to DIN EN 574
- Control category 4 – PL "e" to DIN EN ISO 13849-1 possible

7)

- Malfunctions of every contact as well as earth leakages and cross-wire shorts are detected.
- Feedback circuit ⊕: the feedback circuit is integrated as shown. The safety-technical function of external positive-guided contactors is monitored by a series-wiring of the NC contacts with the terminals X1 and X2. In idle state, this circuit must be closed. If the feedback circuit is not required, establish a bridge.
- Safety category III/C to DIN EN 574
- Control category 4 – PL "e" to DIN EN ISO 13849-1 possible

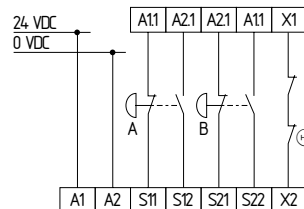

Fig. 46

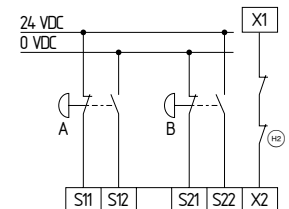

Fig. 47

Actuator configuration

Single-channel control with feedback circuit (Fig. 48)

- Suitable for increase in capacity or number of contacts by means of contactors or relays with positive-guided contacts.
- ⊕ = feedback circuit: If the feedback circuit is not required, establish a bridge.

Dual-channel control with feedback circuit (Fig. 49)

Suitable for increase in capacity or number of contacts by means of contactors or relays with positive-guided contacts.

- ⊕ = feedback circuit: If the feedback circuit is not required, establish a bridge.

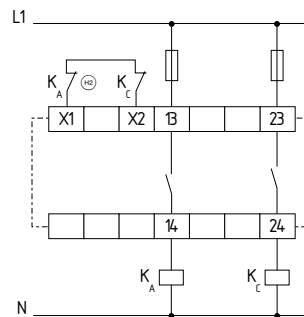

Fig. 48

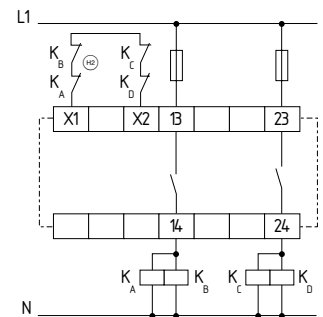

Fig. 49

Differentiated control with feedback circuit (Fig. 50)

- Suitable for increase in capacity or number of contacts by means of contactors or relays with positive-guided contacts.
 - HE = Feedback circuit
- If the feedback circuit is not required, establish a bridge.

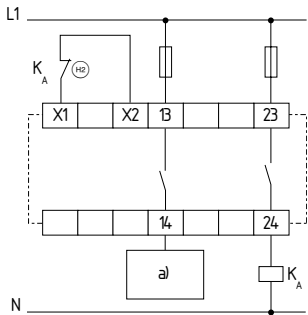

Fig. 50 a) Enabling signal controller

Flow diagram

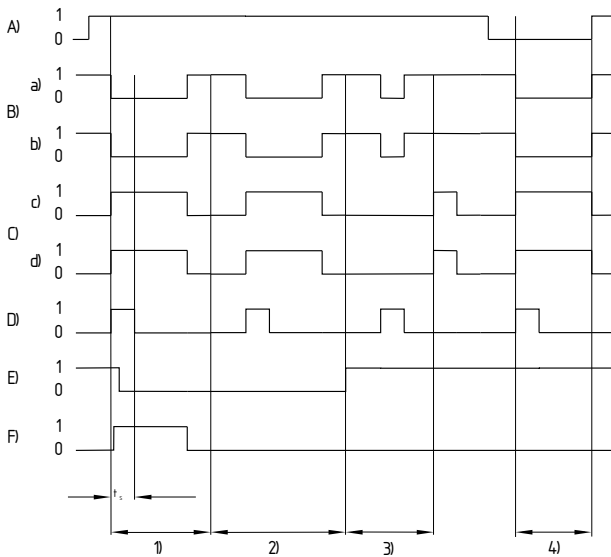



Fig. 51: A) Operating voltage U_B ; B) Two-hand control A: the figure is related to the potentials at the terminals of the safety-monitoring module; a) NC contact S11; b) NO contact S12; C) Two-hand control B: the figure is related to the potentials at the terminals of the safety-monitoring module; c) NC contact S21; d) NO contact S22; D) Simultaneity monitoring t_s (simultaneous actuation); E) Feedback circuit X1-X2; F) Output contacts 13-14, 23-24 potential-free

12.2 EC Declaration of conformity BWT-1 / BWT-2



	
EC Declaration of conformity	
Translation of the original declaration of conformity	Elan Schaltelemente GmbH & Co. KG Im Ostpark 2 · 35435 Wettenberg Germany Internet: www.elan.de
We hereby certify that the hereafter described safety components both in its basic design and construction conform to the applicable European Directives.	
Name of the safety component:	BWT-1 / BWT-2
Description of the safety component:	capacitive two hand control
Harmonised EC-Directives:	2006/42/EC EC-Machinery Directive
Person authorized for the compilation of the technical documentation:	Ulrich Loss Möddinghofe 30 42279 Wuppertal
Place and date of issue:	Wettenberg, October 6, 2009
BWT-B-EN	
	Authorised signature Heinz Schmersal Managing Director



Note
The currently valid declaration of conformity can be downloaded from the internet at www.schmersal.net.



12.3 EC Declaration of conformity EDRR EFR

	
<h2>EC Declaration of conformity</h2> <hr/>	
Translation of the original declaration of conformity	Elan Schaltelemente GmbH & Co. KG Im Ostpark 2 · 35435 Wettenberg Germany Internet: www.elan.de
We hereby certify that the hereafter described safety components both in its basic design and construction conform to the applicable European Directives.	
Name of the safety component:	EDRR + EFR
Description of the safety component:	Emergency stop pushbutton with latching
Harmonised EC-Directives:	2006/42/EC EC-Machinery Directive
Person authorized for the compilation of the technical documentation:	Ulrich Loss Möddinghofe 30 42279 Wuppertal
Place and date of issue:	Wettenberg, October 6, 2009
EDR_EFR-B-EN	
	Authorised signature Heinz Schmersal Managing Director



Note
The currently valid declaration of conformity can be downloaded from the internet at www.schmersal.net.

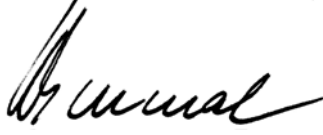

12.4 EC Declaration of conformity KDRR EFR

	
<h2>EC Declaration of conformity</h2>	
Translation of the original declaration of conformity	Elan Schaltelemente GmbH & Co. KG Im Ostpark 2 · 35435 Wettenberg Germany Internet: www.elan.de
We hereby certify that the hereafter described safety components both in its basic design and construction conform to the applicable European Directives.	
Name of the safety component:	KDRR + EFR
Description of the safety component:	Emergency stop pushbutton with latching
Harmonised EC-Directives:	2006/42/EC EC-Machinery Directive
Person authorized for the compilation of the technical documentation:	Ulrich Loss Möddinghofe 30 42279 Wuppertal
Place and date of issue:	Wettenberg, October 6, 2009
KDRR-B-EN	
	Authorised signature Heinz Schmersal Managing Director



Note
The currently valid declaration of conformity can be downloaded from the internet at www.schmersal.net.

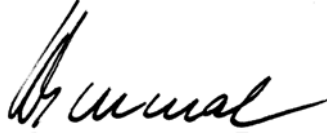

12.5 EC Declaration of conformity ADRR 40

	
<h2>EC Declaration of conformity</h2>	
Translation of the original declaration of conformity	Elan Schaltelemente GmbH & Co. KG Im Ostpark 2 · 35435 Wettenberg Germany Internet: www.elan.de
We hereby certify that the hereafter described safety components both in its basic design and construction conform to the applicable European Directives.	
Name of the safety component:	ADRR 40
Description of the safety component:	Emergency stop pushbutton with latching
Harmonised EC-Directives:	2006/42/EC EC-Machinery Directive
Person authorized for the compilation of the technical documentation:	Ulrich Loss Möddinghofe 30 42279 Wuppertal
Place and date of issue:	Wuppertal, October 6, 2009
ADRR-B-EN	
	Authorised signature Heinz Schmersal Managing Director



Note
The currently valid declaration of conformity can be downloaded from the internet at www.schmersal.net.

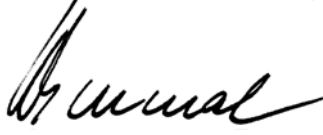

12.6 EC Declaration of conformity EDRZ

	
<h2>EC Declaration of conformity</h2>	
Translation of the original declaration of conformity	Elan Schaltelemente GmbH & Co. KG Im Ostpark 2 · 35435 Wettenberg Germany Internet: www.elan.de
We hereby certify that the hereafter described safety components both in its basic design and construction conform to the applicable European Directives.	
Name of the safety component:	EDRZ
Description of the safety component:	Emergency stop pushbutton with latching
Harmonised EC-Directives:	2006/42/EC EC-Machinery Directive
Person authorized for the compilation of the technical documentation:	Ulrich Loss Möddinghofe 30 42279 Wuppertal
Place and date of issue:	Wettenberg, October 6, 2009
EDRZ-B-EN	
	Authorised signature Heinz Schmersal Managing Director



Note
The currently valid declaration of conformity can be downloaded from the internet at www.schmersal.net.



12.7 EC Declaration of conformity 3SB3

	Erklärung Nr.: Declaration No.: 2846 Déclaration No.:
<p>SIEMENS</p> <p>Diese Konformitätserklärung entspricht der Europäischen Norm EN 45014 "Allgemeine Kriterien für die Konformitätserklärungen von Anbietern". Die Grundlage der Kriterien sind internationale Dokumente, insbesondere ISO/IEC-Leitfaden 22, 1982, "Information on manufacturer's declaration of conformity with standards or other technical specifications".</p> <p><i>This Declaration of Conformity is suitable to the European Standard EN 45014 "General criteria for supplier's declaration of conformity". The basis for the criteria has been found in international documentation, particularly in: ISO/IEC Guide 22, 1982, "Information on manufacturer's declaration of conformity with standards or other technical specifications".</i></p> <p><i>Cette Déclaration de conformité correspond à la norme européenne EN 45014 "Critères généraux pour les déclarations de conformité des fournisseurs". La base des critères sont des documents internationaux, en particulier le guide 22 ISO/IEC de 1982, "Information on manufacturer's declaration of conformity with standards or other technical specifications".</i></p> <p>Änderung Revision Révision</p> <p>Amberg, 2007-09-19 (Ort und Datum der Ausstellung) Place and date of issue Lieu et date de l'édition</p>	<p>EG-Konformitätserklärung EC-Declaration of Conformity CE-Déclaration de conformité</p> <p>Siemens AG / A&D CD CC</p> <p>Wir We/Nous (Name des Anbieters / supplier's name / nom du fournisseur)</p> <p>Werner-von-Siemens-Straße 48 D-92220 Amberg</p> <p>(Anschrift / address / adresse)</p> <p>erklären in alleiniger Verantwortung, daß das (die) Produkt(e) / declare under our sole responsibility that the product(s) / Déclarons sous notre seule responsabilité, que le(s) produit(s)</p> <p>Drucktaster und Leuchtmelder mit NOT-HALT Pushbutton Units and Indicator Lights with EMERGENCY-STOP Boutons-poussoirs et voyants lumineux avec d'arrêt d'urgence</p> <p style="text-align: center;">3SB3</p> <p>(Bezeichnung, Typ oder Modell, Los-, Chargen- oder Serien-Nr., möglichst Herkunft und Stückzahl name, type or model, batch or serial number, possibly sources and number of items nom, type ou modèle, N° de lot ou de série si possible origine et quantité)</p> <p>mit folgenden Europäischen Richtlinien übereinstimmt (übereinstimmen): is (are) in conformity with the following directives: / Répond(ent) aux directives suivantes:</p> <p>Maschinenrichtlinie Nr.: 98/37/EG Machinery Directive No.: 98/37/EC Directive Machine N°: 98/37/CE</p> <p>EMV Richtlinie Nr.: 2004/108/EG EMC Directive No.: 2004/108/EC Directive CEM N°: 2004/108/CE</p> <p>Dies wird nachgewiesen durch die Einhaltung folgender Norm(en) This is documented by the accordance with the following standard(s) Justifié par le respect de la (des) norme(s) suivante(s)</p> <p>DIN EN 60204-1: 2007 DIN EN ISO 13850: 2007 DIN EN 60947-5-5: 2005</p> <p>(Titel und/oder Nr. sowie Ausgabedatum der Norm(en) oder der anderen normativen Dokumente Title and/or number and date of issue of the standard(s) or other normative document(s) Titre et/ou numéro et date d'édition de la (des) norme(s) ou autre(s) document(s) normatif(s))</p> <p><i>i.v. Walker</i> A&D CD CC TS Mr. Walker</p> <p><i>i.v. Schweiger</i> A&D CD-CC TM Mr. Schweiger</p> <p>(Name und Unterschrift oder gleichwertige Kennzeichen des Befugten / Name and signature or equivalent marking of authorized person / Nom et signature ou signe équivalent de la personne autorisée)</p>



Formular: April 1999



Note
 The currently valid declaration of conformity can be downloaded from the internet at www.schmersal.net.



12.8 EC Declaration of conformity SRB 201ZH

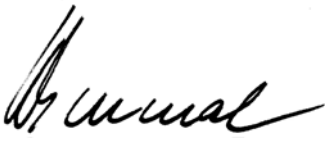

 	
<h2>EC Declaration of conformity</h2>	
Translation of the original declaration of conformity	Elan Schaltelemente GmbH & Co. KG Im Ostpark 2 · 35435 Wettenberg Germany Internet: www.elan.de
We hereby certify that the hereafter described safety components both in its basic design and construction conform to the applicable European Directives.	
Name of the safety component:	SRB 201ZH
Description of the safety component:	Safety-monitoring module for type III/C two-hand controls to DIN EN 574
Harmonised EC-Directives:	2006/42/EC EC-Machinery Directive 2004/108/EC EMC-Directive
Person authorized for the compilation of the technical documentation:	Ulrich Loss Möddinghofe 30 42279 Wuppertal
Notified body, which approved the full quality assurance system, referred to in Appendix X, 2006/42/EC:	TÜV Rheinland Industrie Service GmbH Alboinstraße 56 12103 Berlin ID n°: 0035
Place and date of issue:	Wuppertal, October 6, 2009
SRB201ZH-B-EN	
	Authorised signature Heinz Schmersal Managing Director



Note
The currently valid declaration of conformity can be downloaded from the internet at www.schmersal.net.



12.9 EC Declaration of conformity SEPK 02.0



	
<h2>EC Declaration of conformity</h2> <hr/>	
Translation of the original declaration of conformity	Elan Schaltelemente GmbH & Co. KG Im Ostpark 2 · 35435 Wettenberg Germany Internet: www.elan.de
We hereby certify that the hereafter described safety components both in its basic design and construction conform to the applicable European Directives.	
Name of the safety component:	SEPK 02.0
Description of the safety component:	Two-hand control panel to DIN EN 574
Harmonised EC-Directives:	2006/42/EC EC-Machinery Directive
Person authorized for the compilation of the technical documentation:	Ulrich Loss Möddinghofe 30 42279 Wuppertal
Place and date of issue:	
SEPK02_0-C-EN	 Authorised signature Heinz Schmersal Managing Director



Note
The currently valid declaration of conformity can be downloaded from the internet at www.schmersal.net.



12.10EC Declaration of conformity SEPG 05.3



	
<h2>EC Declaration of conformity</h2>	
Translation of the original declaration of conformity	Elan Schaltelemente GmbH & Co. KG Im Ostpark 2 · 35435 Wettenberg Germany Internet: www.elan.de
We hereby certify that the hereafter described safety components both in its basic design and construction conform to the applicable European Directives.	
Name of the safety component:	SEPG 05.3
Description of the safety component:	Two-hand control panel to DIN EN 574
Harmonised EC-Directives:	2006/42/EC EC-Machinery Directive
Person authorized for the compilation of the technical documentation:	Ulrich Loss Möddinghofe 30 42279 Wuppertal
Place and date of issue:	
SEPG05_3-C-EN	 Authorised signature Heinz Schmersal Managing Director



Note
The currently valid declaration of conformity can be downloaded from the internet at www.schmersal.net.



12.11 EC Declaration of conformity SEP 01.0



	
EC Declaration of conformity	
Translation of the original declaration of conformity	Elan Schaltelemente GmbH & Co. KG Im Ostpark 2 · 35435 Wettenberg Germany Internet: www.elan.de
We hereby certify that the hereafter described safety components both in its basic design and construction conform to the applicable European Directives.	
Name of the safety component:	SEP 01.0
Description of the safety component:	Two-hand control panel to DIN EN 574
Harmonised EC-Directives:	2006/42/EC EC-Machinery Directive
Person authorized for the compilation of the technical documentation:	Ulrich Loss Möddinghofe 30 42279 Wuppertal
Place and date of issue:	
SEP01_0-C-EN	 Authorised signature Heinz Schmersal Managing Director



Note
The currently valid declaration of conformity can be downloaded from the internet at www.schmersal.net.



12.12EC Declaration of conformity SEP 01.4



	
<h2>EC Declaration of conformity</h2>	
Translation of the original declaration of conformity	Elan Schaltelemente GmbH & Co. KG Im Ostpark 2 · 35435 Wettenberg Germany Internet: www.elan.de
<p>We hereby certify that the hereafter described safety components both in its basic design and construction conform to the applicable European Directives.</p>	
Name of the safety component:	SEP 01.4
Description of the safety component:	Two-hand control panel to DIN EN 574
Harmonised EC-Directives:	2006/42/EC EC-Machinery Directive
Person authorized for the compilation of the technical documentation:	Ulrich Loss Möddinghofe 30 42279 Wuppertal
Place and date of issue:	
SEP01_4-C-EN	 Authorised signature Heinz Schmersal Managing Director



Note
The currently valid declaration of conformity can be downloaded from the internet at www.schmersal.net.



12.13EC Declaration of conformity SEPLC 05.2



	
EC Declaration of conformity	
Translation of the original declaration of conformity	Elan Schaltelemente GmbH & Co. KG Im Ostpark 2 · 35435 Wettenberg Germany Internet: www.elan.de
We hereby certify that the hereafter described safety components both in its basic design and construction conform to the applicable European Directives.	
Name of the safety component:	SEPLC 05.2
Description of the safety component:	Two-hand control panel to DIN EN 574
Harmonised EC-Directives:	2006/42/EC EC-Machinery Directive
Person authorized for the compilation of the technical documentation:	Ulrich Loss Möddinghofe 30 42279 Wuppertal
Place and date of issue:	
SEPLC05_2-C-EN	 Authorised signature Heinz Schmersal Managing Director



Note
The currently valid declaration of conformity can be downloaded from the internet at www.schmersal.net.



12.14EC Declaration of conformity SEP 07.0



	
<h2>EC Declaration of conformity</h2>	
Translation of the original declaration of conformity	Elan Schaltelemente GmbH & Co. KG Im Ostpark 2 · 35435 Wettenberg Germany Internet: www.elan.de
We hereby certify that the hereafter described safety components both in its basic design and construction conform to the applicable European Directives.	
Name of the safety component:	SEP 07.0
Description of the safety component:	Two-hand control panel to DIN EN 574
Harmonised EC-Directives:	2006/42/EC EC-Machinery Directive
Person authorized for the compilation of the technical documentation:	Ulrich Loss Möddinghofe 30 42279 Wuppertal
Place and date of issue:	
SEP07_0-C-EN	 Authorised signature Heinz Schmersal Managing Director



Note
The currently valid declaration of conformity can be downloaded from the internet at www.schmersal.net.



12.15EC Declaration of conformity SEP 09.0

	
<h2>EC Declaration of conformity</h2>	
Translation of the original declaration of conformity	Elan Schaltelemente GmbH & Co. KG Im Ostpark 2 · 35435 Wettenberg Germany Internet: www.elan.de
We hereby certify that the hereafter described safety components both in its basic design and construction conform to the applicable European Directives.	
Name of the safety component:	SEP 09.0
Description of the safety component:	Two-hand control panel to DIN EN 574
Harmonised EC-Directives:	2006/42/EC EC-Machinery Directive
Person authorized for the compilation of the technical documentation:	Ulrich Loss Möddinghofe 30 42279 Wuppertal
Place and date of issue:	
SEP09_0-C-EN	 Authorised signature Heinz Schmersal Managing Director



Note

The currently valid declaration of conformity can be downloaded from the internet at www.schmersal.net.



Elan Schaltelemente GmbH & Co. KG
Im Ostpark 2, D - 35435 Wettenberg
Postfach 1109, D - 35429 Wettenberg

Telefon: +4 9 (0)6 41 9848-0
Telefax: +49 (0)641 9848-420
E-Mail: info-elan@schmersal.com
Internet: www.elan.de