



EN Operating instructions.pages 1 to 6
Translation of the original operating instructions

Content

1 About this document

1.1 Function 1

1.2 Target group: authorised qualified personnel. 1

1.3 Explanation of the symbols used 1

1.4 Appropriate use 1

1.5 General safety instructions 1

1.6 Warning about misuse 2

1.7 Exclusion of liability 2

2 Product description

2.1 Ordering code 2

2.2 Special versions. 2

2.3 Destination and use 2

2.4 Technical data 2

2.5 Safety classification 3

3 Mounting

3.1 General mounting instructions 3

3.2 Dimensions 3

4 Electrical connection

4.1 General information for electrical connection. 3

5 Operating principle and settings

5.1 LED functions. 3

5.2 Description of the terminals 3

5.3 Notes 3

6 Set-up and maintenance

6.1 Functional testing. 4

6.2 Maintenance 4

7 Disassembly and disposal

7.1 Disassembly. 4

7.2 Disposal 4

8 Appendix

8.1 Wiring examples 4

8.2 Sensor configuration 4

8.3 Actuator configuration 5

8.4 Flow diagram 5

9 Declaration of conformity

9.1 EC Declaration of conformity 6

1. About this document

1.1 Function
This operating instructions manual provides all the information you need for the mounting, set-up and commissioning to ensure the safe operation and disassembly of the safety-monitoring module. The operating instructions must be available in a legible condition and a complete version in the vicinity of the device.

1.2 Target group: authorised qualified personnel
All operations described in this operating instructions manual must be carried out by trained specialist personnel, authorised by the plant operator only.

Please make sure that you have read and understood these operating instructions and that you know all applicable legislations regarding occupational safety and accident prevention prior to installation and putting the component into operation.

The machine builder must carefully select the harmonised standards to be complied with as well as other technical specifications for the selection, mounting and integration of the components.

1.3 Explanation of the symbols used

 **Information, hint, note:**
This symbol is used for identifying useful additional information.

 **Caution:** Failure to comply with this warning notice could lead to failures or malfunctions.
Warning: Failure to comply with this warning notice could lead to physical injury and/or damage to the machine.

1.4 Appropriate use
The products described in these operating instructions are developed to execute safety-related functions as part of an entire plant or machine. It is the responsibility of the manufacturer of a machine or plant to ensure the correct functionality of the entire machinery or plant.

The safety-monitoring module must be exclusively used in accordance with the versions listed below or for the applications authorised by the manufacturer. Detailed information regarding the range of applications can be found in the chapter "Product description".

1.5 General safety instructions
The user must observe the safety instructions in this operating instructions manual, the country-specific installation standards as well as all prevailing safety regulations and accident prevention rules.

 Further technical information can be found in the online catalogue on the Internet: www.schmersal.net.

The information contained in this operating instructions manual is provided without liability and is subject to technical modifications.

 The entire concept of the control system, in which the safety component is integrated, must be validated to EN ISO 13849-2.

There are no residual risks, provided that the safety instructions as well as the instructions regarding mounting, commissioning, operation and maintenance are observed.

1.6 Warning about misuse



In case of inadequate or improper use or manipulations of the safety-monitoring module, personal hazards or damage to machinery or plant components cannot be excluded. The relevant requirements of the standard EN 1088 must be observed.

1.7 Exclusion of liability

We shall accept no liability for damages and malfunctions resulting from defective mounting or failure to comply with this operating instructions manual. The manufacturer shall accept no liability for damages resulting from the use of unauthorised spare parts or accessories.

For safety reasons, invasive work on the device as well as arbitrary repairs, conversions and modifications to the device are strictly forbidden; the manufacturer shall accept no liability for damages resulting from such invasive work, arbitrary repairs, conversions and/or modifications to the device.

The safety-monitoring module must only be used when the enclosure is closed, i.e. with the front cover fitted.

2. Product description

2.1 Ordering code

This operating instructions manual applies to the following types:

SRB 201ZH



Only if the information described in this operating instructions manual are realised correctly, the safety function and therefore the compliance with the Machinery Directive is maintained.

2.2 Special versions

For special versions, which are not listed in the order code below 2.1, these specifications apply accordingly, provided that they correspond to the standard version.

2.3 Destination and use

The safety-monitoring modules for integration in safety circuits are designed for fitting in control cabinets. They are used for the safe evaluation of the signals of two actuating elements A + B and correspond to a type III/C two-hand control to DIN EN 574.

The safety function is defined as the opening of the enabling circuits 13-14 and 23-24 when one or both actuating elements A + B are released. The safety-relevant current paths with the output contacts 13-14 and 23-24 meet the following requirements under observation of a PFH value assessment (also refer to "Requirements to DIN EN ISO 13849-1"):

- control category 4 – PL e to DIN EN ISO 13849-1
- corresponds to SIL 3 to DIN EN 61508-2
- corresponds to SILCL 3 to DIN EN 62061

To determine the Performance Level (PL) of the entire safety function (e.g. sensor, logic, actuator) to DIN EN ISO 13849-1, an analysis of all relevant components is required.

2.4 Technical data

General data

Standards:	IEC/EN 60204-1, EN 60947-5-1; EN ISO 13849-1, IEC 61508
Climate resistance:	EN 60068-2-78
Mounting:	snaps onto standard DIN rail to EN 60715
Terminal designations:	EN 60947-1
Material of the housings:	glass-fibre reinforced thermoplastic, ventilated
Material of the contacts:	AgSnO, self-cleaning, positive drive
Weight:	200 g
Start conditions:	Automatic
Feedback circuit (Y/N):	yes
Pull-in delay for automatic start:	typ. 50 ms
Response time:	typ. 30 ms / max. 37 ms
Bridging in case of voltage drops:	typ. 30 ms
Simultaneity monitoring:	≤ 0.5 s

Mechanical data

Connection type:	Screw connection
Cable section:	min. 0,25 mm ² / max. 2,5 mm ²
Connecting cable:	rigid or flexible
Tightening torque for the terminals:	0,6 Nm
With removable terminals (Y/N):	yes
Mechanical life:	10 million operations
Electrical life:	Derating curve available on request
Resistance to shock:	30 g / 11 ms
Resistance to vibrations to EN 60068-2-6:	10 ... 55 Hz, amplitude 0.35 mm

Ambient conditions

Ambient temperature:	-25 °C ... +60 °C
Storage and transport temperature:	-40 °C ... +85 °C
Protection class:	Enclosure: IP40 Terminals: IP20 Clearance: IP54

Air clearances and creepage distances to IEC/EN 60664-1:	4 kV/2 (basic insulation)
EMC rating:	to EMC Directive

Electrical data

Contact resistance in new state:	max. 100 mΩ
Power consumption:	max. 1.2 W
Rated operating voltage U _e :	24 VDC -10% / +10%, residual ripple max. 10%
Fuse rating for the operating voltage:	Internal electronic trip: F1, F2: tripping current > 0.2 A F3: tripping current > 0.6 A

Monitored inputs

Cross-wire detection (Y/N):	Yes
Wire breakage detection (Y/N):	Yes
Earth leakage detection (Y/N):	Yes
Number of NO contacts:	2 pieces
Number of NC contacts:	2 pieces
Cable length:	1,500 m mit 1.5 mm ² 2,500 m mit 2.5 mm ²
Conduction resistance:	max. 40 Ω

Outputs

Number of safety contacts:	2 (13-14; 23-24)
Number of auxiliary contacts:	1 (31-32)
Number of signalling outputs:	0
Switching capacity of the safety contacts:	max. 250 V, 6 A ohmic (inductive in case of appropriate protective wiring); min. 10 V / 10 mA
Switching capacity of the auxiliary contacts:	24 VDC / 2 A
Protection of the safety contacts:	external (I _k = 1000 A) to EN 60947-5-1; Safety fuse 8 A quick blow, 6.3 A slow blow
Fuse rating for the auxiliary contacts:	2.5 A quick blow, 2 A slow blow
Utilisation category to EN 60947-5-1:	AC-15: 230 V / 6 A DC-13: 24 V / 6 A
Dimensions H x W x D:	100 x 22.5 x 121 mm

The data specified in this manual are applicable when the component is operated with rated operating voltage U_e ±0%.

2.5 Safety classification

Standards:	EN ISO 13849-1, IEC 61508, EN 60947-5-1, DIN EN 574, EN 60204-1
PL:	up to e
Control category:	up to 4
DC:	99% (high)
CCF:	> 65 points
PFH value:	$\leq 2.00 \times 10^{-8}/h$
SIL:	up to 3
Service life:	20 years

The PFH value of $2.00 \times 10^{-8}/h$ applies to the combinations of contact load (current through enabling contacts) and number of switching cycles (n_{oply}) mentioned in the table below. At 365 operating days per year and a 24-hours operation, this results in the below-mentioned switching cycle times (t_{cycle}) for the relay contacts. Diverging applications upon request.

Contact load	n_{oply}	t_{cycle}
20 %	525,600	1.0 min
40 %	210,240	2.5 min
60 %	75,087	7.0 min
80 %	30,918	17.0 min
100 %	12,223	43.0 min

3. Mounting

3.1 General mounting instructions

Mounting: snaps onto standard DIN rails to EN 60715.

Snap the bottom of the enclosure slightly tilted forwards in the DIN rail and push up until it latches in position.

3.2 Dimensions

All measurements in mm.

Device dimensions (H/W/D): $100 \times 22.5 \times 121$ mm
with plugged-in terminals: $120 \times 22.5 \times 121$ mm

4. Electrical connection

4.1 General information for electrical connection



The electrical connection may only be carried out by authorised personnel in a de-energised condition.



As far as the electrical safety is concerned, the protection against unintentional contact of the connected and therefore electrically interconnected apparatus and the insulation of the feed cables must be designed for the highest voltage, which can occur in the device.

Wiring examples: see appendix

5. Operating principle and settings

5.1 LED functions

K1: Status channel 1
K2: Status channel 2

5.2 Description of the terminals

Voltages:	A1	+24 VDC
	A1.1	+ 24 V
	A2	0 VDC
	A2.1	0 V
Inputs:	S11	Input channel 1 (+)
	S12	Input channel 1 (-)
	S21	Input channel 2 (-)
	S22	Input channel 2 (+)
Outputs:	13 - 14	First safety enabling circuit
	23 - 24	Second safety enabling circuit
	31 - 32	Auxiliary NC contact
Start:	X1 - X2	Feedback circuit

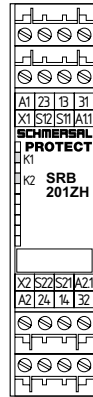

Fig. 1

5.3 Notes



Signalling outputs must not be used in safety circuits.



The NC contact of the buttons A + B must be opened, before the NO contact closes. No overlapping contacts to avoid triggering of the fuses F1 and F2.



The pushbuttons A + B must be actuated within a timeframe of ≤ 0.5 sec (simultaneous operation monitoring), otherwise no start enabling signal is given!

6. Set-up and maintenance

6.1 Functional testing

The safety function of the safety-monitoring module must be tested. The following conditions must be previously checked and met:

1. Correct fixing
2. Check the integrity of the cable entry and connections
3. Check the safety-monitoring module's enclosure for damage.
4. Check the electrical function of the connected sensors and their influence on the safety-monitoring module and the downstream actuators

6.2 Maintenance

A regular visual inspection and functional test, including the following steps, is recommended:

1. Check the correct fixing of the safety-monitoring module
2. Check the cable for damages
3. Check electrical function



The device has to be integrated into the periodic check-ups according to the Ordinance on Industrial Safety and Health, however at least 1 × year.

Damaged or defective components must be replaced.

7. Disassembly and disposal

7.1 Disassembly

The safety-monitoring module must be disassembled in a de-energised condition only.

Push up the bottom of the enclosure and hang out slightly tilted forwards.

7.2 Disposal

The safety-monitoring module must be disposed of in an appropriate manner in accordance with the national prescriptions and legislations.

8. Appendix

8.1 Wiring examples

Dual-channel control with two pushbuttons A and B (see Fig. 2)

- Relay outputs: Suitable for 2-channel control, for increase in capacity or number of contacts by means of contactors or relays with positive-guided contacts.

- HE = Feedback circuit

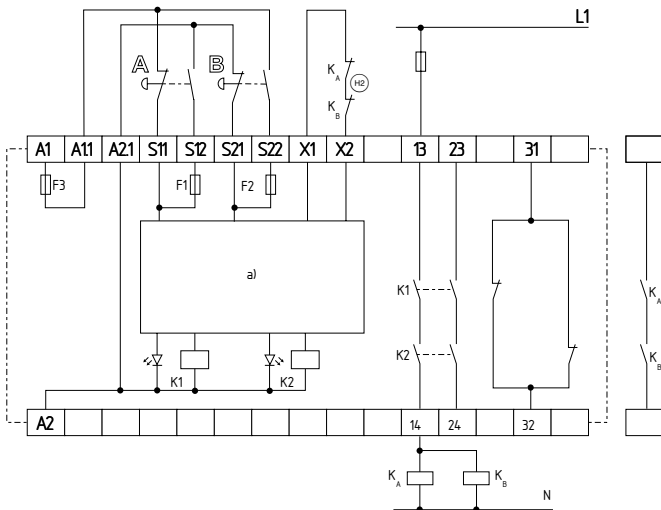

Fig. 2 a) Logic

8.2 Sensor configuration

Two-hand control to DIN EN 574 and EN 60204-1 (see Fig. 3)

- Malfunctions of every contact as well as earth leakages and cross-wire shorts are detected.
- Feedback circuit HE : The feedback circuit is integrated as shown. The safety-technical function of external positive-guided contactors is monitored by a series-wiring of the NC contacts with the terminals X1 and X2. In idle state, this circuit must be closed. If the feedback circuit is not required, establish a bridge.
- Safety category III/C to DIN EN 574
- Category 4 – PL e to DIN EN ISO 13849-1 possible.

Two-hand control to DIN EN 574 and EN 60204-1 (see Fig. 4)

- Malfunctions of every contact as well as earth leakages and cross-wire shorts are detected.
- Feedback circuit HE : The feedback circuit is integrated as shown. The safety-technical function of external positive-guided contactors is monitored by a series-wiring of the NC contacts with the terminals X1 and X2. In idle state, this circuit must be closed. If the feedback circuit is not required, establish a bridge.
- Safety category III/C to DIN EN 574
- Category 4 – PL e to DIN EN ISO 13849-1 possible.

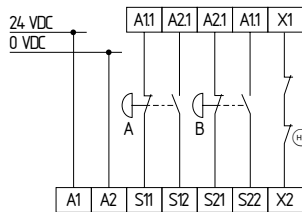

Fig. 3

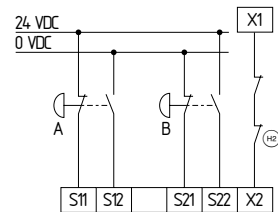

Fig. 4

8.3 Actuator configuration

Single-channel control with feedback circuit (Fig. 5)

- Suitable for increase in capacity or number of contacts by means of contactors or relays with positive-guided contacts.
- Ⓜ = feedback circuit:
If the feedback circuit is not required, establish a bridge.

Dual-channel control with feedback circuit (Fig. 6)

- Suitable for increase in capacity or number of contacts by means of contactors or relays with positive-guided contacts.
- Ⓜ = feedback circuit:
If the feedback circuit is not required, establish a bridge.

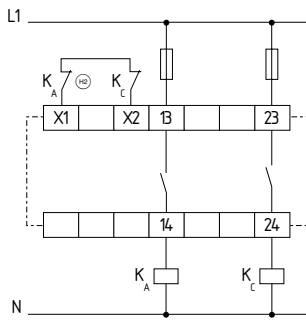

Fig. 5

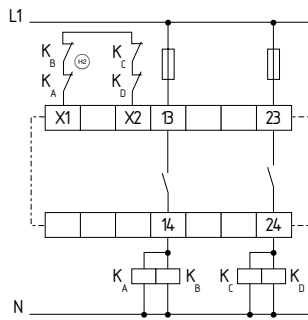

Fig. 6

Differential control with feedback circuit (see Fig. 7)

- Suitable for increase in capacity or number of contacts by means of contactors or relays with positive-guided contacts.
- Ⓜ = feedback circuit:
If the feedback circuit is not required, establish a bridge.

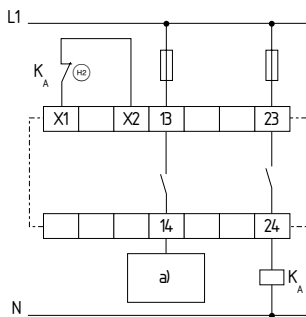

Fig. 7 a) Enabling signal controller

8.4 Flow diagram

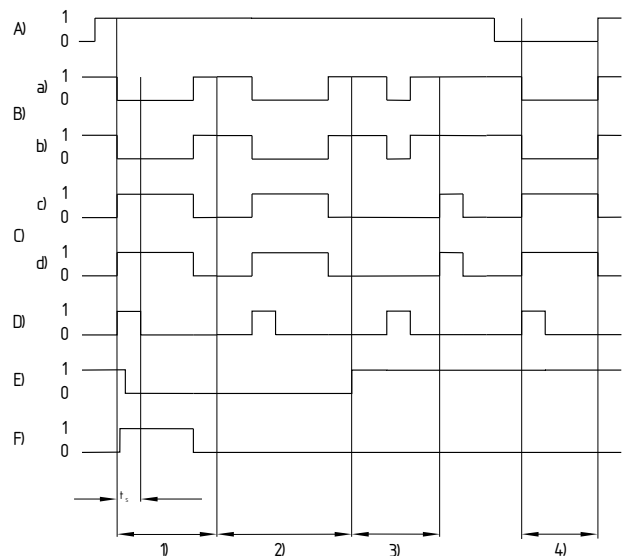





Fig. 8

Legend

- 1) uninterrupted workcycle;
 - 2) Fault in feedback circuit;
 - 3) Synchronous actuation fault $t > 0.5$ s
 - 4) Fault button A, B before $U_{B\text{in}}$;
- A) Operating voltage U_B ;
 B) Two-hand button A: the representation is related to the potentials at the terminals of the safety-monitoring module;
 a) NC contact S11; b) NO contact S12;
 C) Two-hand button B: the representation is related to the potentials at the terminals of the safety-monitoring module;
 c) NC contact S21; d) NO contact S22;
 D) Simultaneity monitoring t_s (synchronous actuation);
 E) Feedback circuit X1-X2;
 F) Output contacts 13-14, 23-24 potential-free

9. Declaration of conformity

9.1 EC Declaration of conformity

EC Declaration of conformity		 
Translation of the original declaration of conformity valid as of December 29, 2009		Elan Schaltelemente GmbH & Co. KG Im Ostpark 2, 35435 Wettenberg Germany Internet: www.elan.de
We hereby certify that the hereafter described safety components both in its basic design and construction conform to the applicable European Directives.		
Name of the safety component:		SRB 201ZH
Description of the safety component:		Safety-monitoring module for type III/C two-hand controls to DIN EN 574
Harmonised EC-Directives:		2006/42/EC EC-Machinery Directive 2004/108/EC EMC-Directive
Person authorized for the compilation of the technical documentation:		Ulrich Loss Möddinghofe 30 42279 Wuppertal
Notified body, which approved the full quality assurance system, referred to in Appendix X, 2006/42/EC:		TÜV Rheinland Industrie Service GmbH Alboinstraße 56 12103 Berlin ID n°: 0035
Place and date of issue:		Wettenberg, October 6, 2010
		
		Authorised signature Heinz Schmersal Managing Director

SRB201ZH-B-EN



The currently valid declaration of conformity can be downloaded from the internet at www.schmersal.net.



Elan Schaltelemente GmbH und Co. KG

Im Ostpark 2, D - 35435 Wettenberg
Postfach 11 09, D - 35429 Wettenberg

Telefon +49 - (0)6 41 - 98 48 - 0
Telefax +49 - (0)6 41 - 98 48 - 4 20
E-Mail: info-elan@schmersal.com
Internet: <http://www.elan.de>