



Features & Benefits

- **Highly tamper-resistant actuating mechanism** ... difficult to defeat with simple tools, tape, bent wires, etc. Reduces liability exposure.
- **Four optional key entry locations** ... rotatable actuator head provides installation versatility.
- **“Positive-Break” NC contacts** ... assure circuit interruption upon actuator key removal.
- **Built-in retention force (1.2 pounds)** ... eliminates inadvertent opening of guard due to shock/vibration.
- **Watertight design** ... meets IP67 washdown requirements.
- **High-strength steel actuator key** ... tolerates mechanical abuse without damage.
- **Rugged, corrosion-resistant metal housing** ... tolerates the most hostile environments.
- **Wide selection of actuating keys** ... to meet diverse application requirements.
- **Meets rigid safety agency standards** ... BG, UL, CSA.
- **Funnel-shaped key entry** ... forgiving of key misalignment.
- **Other 2-contact configurations available** ... please consult factory.

Description

The Series SDG is designed for use with movable machine guards/access gates which must be closed for operator safety. Their positive-opening NC contacts provide a significantly higher level of safety than conventional spring-driven switches whose contacts can weld or stick shut. And their tamper-resistant design prevents bypassing with simple tools, bent wires or other readily available means. Their IP67 rating makes them ideal for interlocking safety guards in hostile environments.

Operation

The Series SDG electromechanical safety interlock switch consists of a rugged switch mechanism and a geometrically-unique actuating key. The key is mounted to the movable guard. Upon opening of the guard the NC contact(s) are forced to open through a direct (non-resilient) mechanical linkage with the actuating key. These positive-break NC contacts assure circuit interruption (and machine stoppage) upon removal of the actuator key. (The NO contact closes upon key removal.)

When the guard is closed, the actuating key forces the NC contacts to close and the NO contact to re-open.

Typical Applications



The Series SDG is intended for use as a safety interlock switch on movable machine guards which, when open, expose the operator/maintenance personnel to machine hazards. Typical applications are the interlocking of protective gratings, access doors/gates, hinged covers, access panels and other movable guards.

SDG AVAILABLE MODELS AND ACCESSORIES

AVAILABLE STANDARD MODELS (Includes 1/2" NPT Conduit Adapter. Actuator Keys Sold Separately)

Part Number	Contacts	Description*
SDG01.1044	2 NO & 1 NC	Keyed interlock switch with front* key entry and slow action contacts.
SDG01.1103	1 NO & 2 NC	
SDG01.1110	3 NC	

*Field-rotatable for key entry from right, left or rear. Units are supplied with tamper-resistant (one-way) screws to replace the standard screws after rotating the actuator head for desired direction of key entry.

OPTIONAL ACTUATOR KEYS

Part Number	Description
BO	Standard straight actuator key (20" minimum closing radius)
BOW	Right-angled straight actuator key (20" minimum closing radius)
BOR	Radial entry actuator key (10" minimum closing radius)
BOWR	Right-angled bent actuator key (10" minimum closing radius)
BOF/HIS.1	Pivoting straight actuator key (rear-mounted) (13.8" Minimum closing radius)
BOF/HIS.2	Pivoting straight actuator key (top-mounted) (13.8" Minimum closing radius)

1

DIMENSIONS

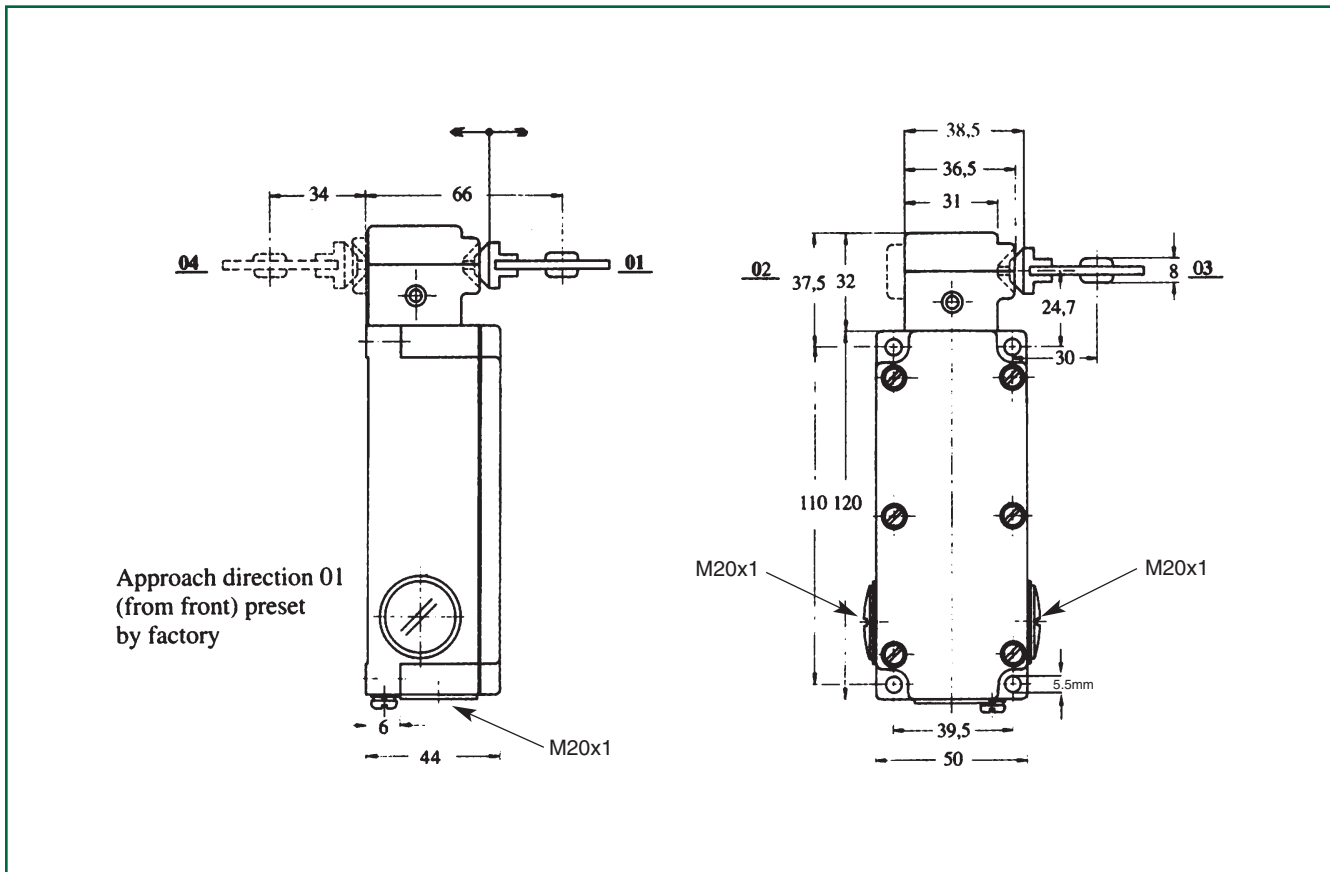

SDG TECHNICAL DATA

MECHANICAL SPECIFICATIONS

Housing	Cast aluminum with enamel paint
Actuator Key	Steel (chromated) (defeat-resistant design)
Degree of Protection	IP67 (Switch housing) IP00 (Reversing and locking head)
Holding Force	5N (1.2 pounds)
Travel for Positive-Break	12.5mm
Force to Reach Positive-Break	Approx. 5N (1.2 pounds)
Closing Force	Approx. 5N (1.2 pounds)
Operating Temperature	-13°F to +158°F
Mechanical Life	1 million operations (minimum)
Shock Resistance	>30g / 18ms
Vibration Resistance	>15g / 10...200Hz
Conformity to Standards	IEC 947-5-1 EN 60947-5-1 DIN VDE 0660-100 BG-GS-ET-15 UL CSA
Minimum Closing Radius	Dependent upon actuator key used. Please see actuator key selection chart.

ELECTRICAL SPECIFICATIONS

Contacts	Fine silver
Contact Configuration	Double-pole, double-break with electrically separated contact bridges
Contact Gap	2 × 3.5 mm
Contact Rating	8A (250VAC)
Switching Action	Slow-action, positive-break NC contacts
Short Circuit Protection	10A (slow-blow)
Rated Insulation Voltage	250VAC
Rated Impulse Withstand Voltage	4kV
Type Terminals	Screw terminals with self-lifting clamps for up to 13 AWG solid wire (2.5mm ²) or 13 AWG stranded (1.5mm ²) wire

SDG ACTUATOR KEY SPECIFICATIONS

ACTUATOR KEYS

1

