

Features & Benefits

- **“Positive-Break” NC contacts** ... won't stick or weld shut.
- **Watertight design** ... meets IP65 washdown requirements.
- **Rugged, corrosion-resistant housing** ... tolerates hostile environments.
- **Five popular actuator styles** ... for application versatility.
- **Four 90° actuator mounting positions** ... provide installation flexibility.
- **Safety-system approved** ... for use in machine guarding applications.
- **Meets rigid safety agency standards** ... IEC, BG, VDE, and CSA.

Description

The Z332 Series limit switches are designed for use with movable machine guards/access gates which must be closed for operator safety ... and for any other presence/position sensing application normally addressed with conventional limit switches. Their positive-opening NC contacts provide a higher level of safety and/or reliability than conventional spring-driven switches whose contacts can weld or stick shut.

Each is available with a choice of five standard actuators ... rounded plunger, roller plunger, roller rocking lever, rod rocking lever and adjustable roller rocking lever ... mountable in any one of four 90° positions. All rocking levers are positively-locked to the shaft, and are adjustable throughout 360° in 10° increments.

Their rugged metal housing and IP65 rating make them ideal alternatives to conventional limit switches.

Typical Applications

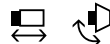

The Z332 Series may be used in any presence/position sensing application normally addressed with conventional limit switches. Featuring positive-break NC contacts, they are approved for use in safety systems. For safety applications the switch must be mounted such that the actuating element of the machine displaces the switch actuator far enough to exceed the positive-break point. (See contact function diagrams: symbol *).

ORDERING GUIDE

FOR FEATURE:	SPECIFY:
1. Contact operation: Snap Action	Z
2. Operating head	4V
3. Roller lever	H
4. Body size	332-
5. No. of NO contacts	1
6. No. of NC contacts	1
7. Degree of protection IP 65	y
Example:	Z4VH 332-11y

Z332 TECHNICAL DATA

MECHANICAL SPECIFICATIONS

Housing	Diecast aluminum with enamel finish
Operating Temperature	-22°F to +195°F (-30°C to +90°C)
Mechanical Life	1 million operations
Minimum Cam Speed (Referenced to Plunger)	1 mm/minute
Maximum Operating Rate	5000 operations/hour
Bounce Time	2 ms
Changeover Time	1.5 ms for minimum cam speed
Degree of Protection	IP65
Conformity to Standards	IEC 947-5-1 EN 60947-5-1 DIN VDE 0660 Part 200 BG-GS-ET-15 DIN EN 50041 CSA-C22.2 No. 14 (Suffix -1220)

ELECTRICAL SPECIFICATIONS

Contacts	Fine silver
Contact Configuration	Double-pole, double-break with electrically-separated contact bridges
Contact Gap	2 × 0.05 in. immediately after switching 2 × 0.19 in. with full travel of actuator
Contact Rating	2.5A/250VAC
Switching Action	Z332 Series: Snap-action with positive-break NC contacts
Short Circuit Protection	Fuse: 20A (time delay) 25A (no time delay) 6A (time delay) as positive-break position switch
Rated Insulation Voltage	250VAC
Rated Impulse Withstand Voltage	6kV
Type Terminals	Screw terminals, maximum 2.5mm (AWG13) wire

Contact System



Magnetic storage snap-action system

SNAP ACTION CONTACT SYSTEMS

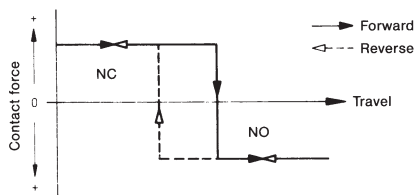

- Snap-action switching, 1 NO 1 NC
- Change-over, double-gap with four terminals
- Two electrically separated moving contacts
- Plated solid silver contacts
- Positive-break NC contact with snap-action switching
- Reliable change-over, even with slow plunger actuation
- Snap-action system separated from contact system
- Full contact force right up to operating point
- Constant operating position, as independent of contact burning
- Short, constant flight time of only 1.5 ms
- Short bounce time
- High short-circuit resistance
- High vibration resistance of 10 g still only 0.01 mm before operating point
- Wide contact gap of 2 × 1.25 mm immediately after switching point

Z332 TECHNICAL DATA

Contact function diagrams

Snap action positive break
1 NO + 1 NC

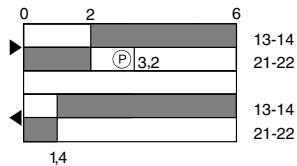

ZS 332-11y

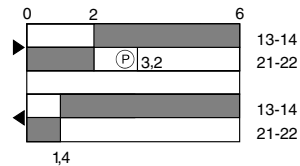

ZR 332-11y



Dimensions

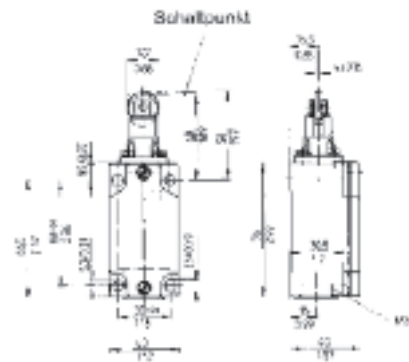
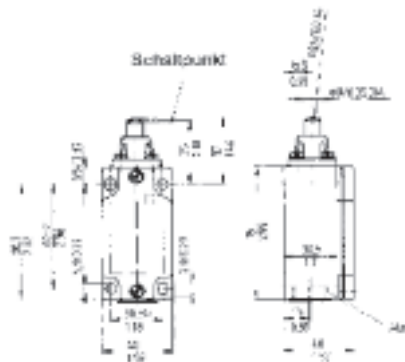
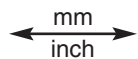

Types of Actuators

Rounded plunger
Style S

Roller plunger
Style R

Part No.		Snap Action positive break	Actuating Force			
			ZS 332-11y	31 N	ZR 332-11y	31 N

Z332 TECHNICAL DATA

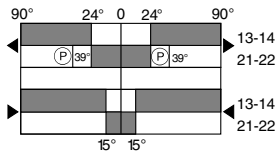

Z4VH 332-11y

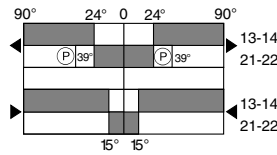

Z4V7H 332-11y

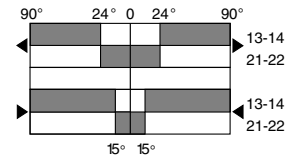

Z4V10H 332-11z

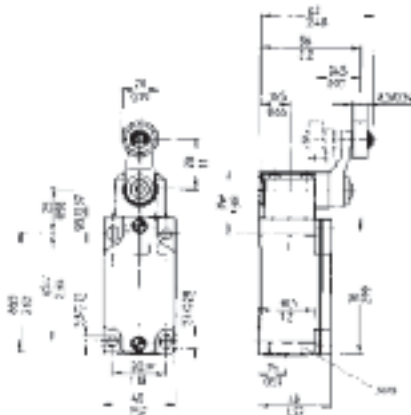

**4V operating head with roller rocking lever
Style H**

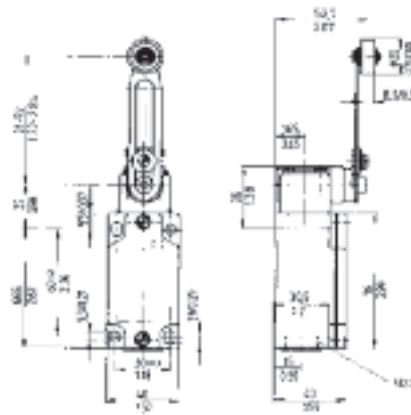

**4V operating head with adjustable roller lever
Style 7H***

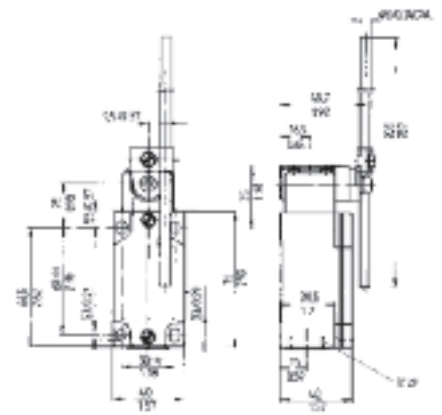

**4V operating head with rod rocking lever
Style 10H***

Actuating Force		Actuating Force		Actuating Force	
Z4VH 332-11y	35 Ncm	Z4V7H 332-11y*	35 N	Z4V10H 332-11y*	35 Ncm

* Not for use in safety applications