

Axi-dyne® BCS/MCS Screw Drives

OVERVIEW



APPLICATION BENEFITS

- Moderate load carrying capabilities at an economical price
- Easily retrofittable and interchangeable
- Adjustable carrier and self-lubricating bearings for easy maintenance

GUIDANCE SYSTEM

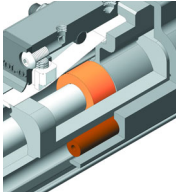

A patented* adjustable carrier bracket transmits the load to the cylinder body, instead of the screw for true tracking, superior load support and controlled minimum friction load. Two self-lubricating Delrin bearing rods, pass force directly to the cylinder tube. Patented** Band Retention system uses a T-shaped elastomer strip bonded to a stainless steel band, inserted directly into the body housing forming a tight metal-to-metal seal for clean operation.

*U.S. Patent No. 4724744

**U.S. Patent No. 4545290

STANDARD MOUNTING



Mounting holes are provided on the underside of the cylinder heads. To mount, transfer the location of holes to the receiving surface. Drill mounting holes 1/32" larger than diameter of the mounting screws and attach securely with appropriate screws.

ACTUATOR/MOTOR FACTORS

- Actuator's operating temperature range (40-130° F, 4-54° C) should take into consideration heat generated by the motor and drive, linear velocity and work cycle time.
- For large frame motors or small actuators, cantilevered motors need to be supported, if subjected to continuous rapid reversing duty and/or under dynamic conditions.

AVAILABLE OPTIONS

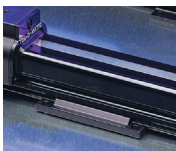

Tube Supports: Provide intermediate support of actuator body at the recommended intervals. They are designed to fit into the dove-tailed grooves running the entire length of the cylinder tube.



Mounting Plates: Provide clearance height for motors and motor mounts when mounting an actuator on a flush surface. Mounted to the tapped holes in cylinder heads, they provide the means for top mounting access. Kits include plates and mounting screws.



Floating Mount Bracket: Compensates for non-parallelism between the actuator and an external support/guidance system. These mounts should be used on independently-guided loads to eliminate actuator binding. Use of the Float Mount, adds 0.014" (0.36 mm) to the backlash.



Auxiliary Carrier: Increases rigidity, load-carrying capacity and bending moments

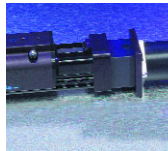

Motor Mounting and Gearhead Reduction:

In-line Motor Mounting—This motor mounting option uses a spacer and coupler to join the motor to the actuator shaft.

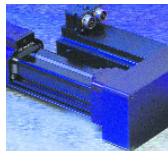

Reverse-parallel Motor Mounting—These factory assembled configurations allow offset mounting of the motor to either side of, or below the actuator. Available in 1:1 or 2:1 drive ratios, they offer quiet, zero-backlash coupling of the motor to the actuator screw shaft.



Gearhead Reduction—Gearheads are available for applications requiring reduction for inertia matching or higher torque at lower speeds. High efficiency, single stage, true planetary gearheads are available in 5.5:1 and 10:1 ratios for reduction solutions with most Tol-O-Matic NEMA 23 and 34 face motors. See page F-10.



Switches: Reed, dc Hall-effect and ac TRIAC. See section I.

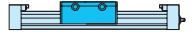

RODLESS

BCS/MCS Series

- Application benefits
- Guidance system
- Standard mounting
- Actuator/motor factors
- Available options

Axi-dyne® BCS/MCS Screw Drives

ACME SCREW/NUT COMBINATIONS

ACME SCREW CRITICAL SPEED CAPACITIES

CRITICAL SPEED WITH ENGLISH ACME SCREW

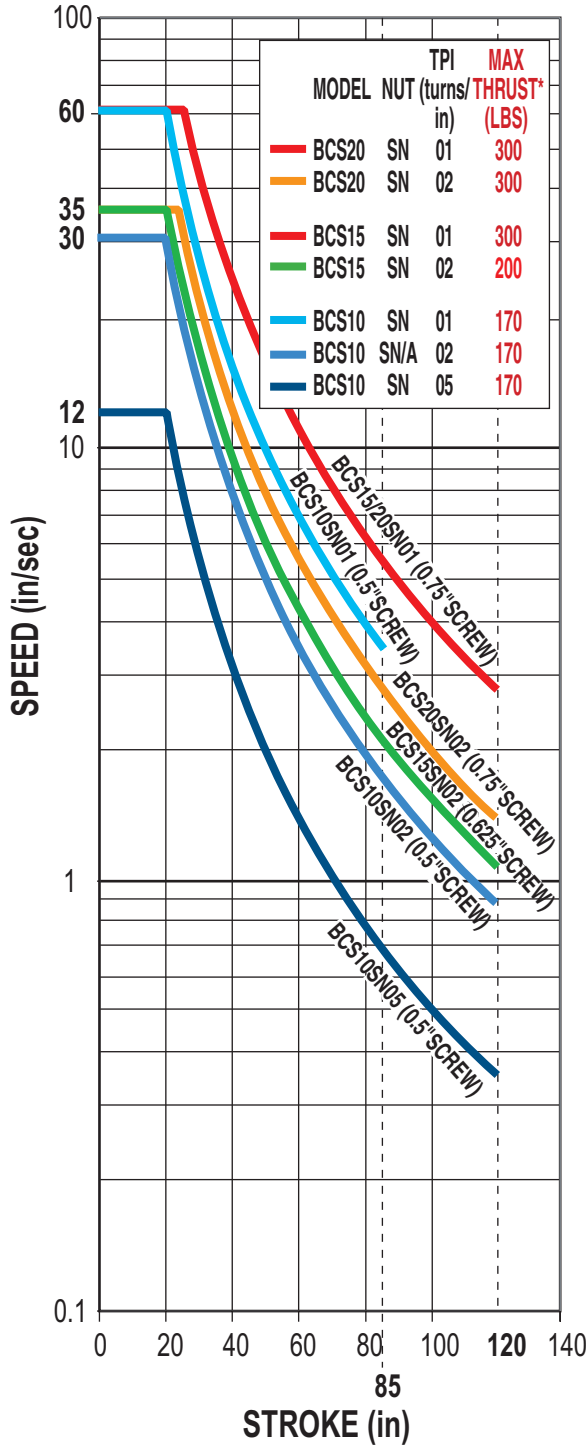

CRITICAL SPEED WITH METRIC ACME SCREW

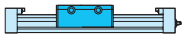
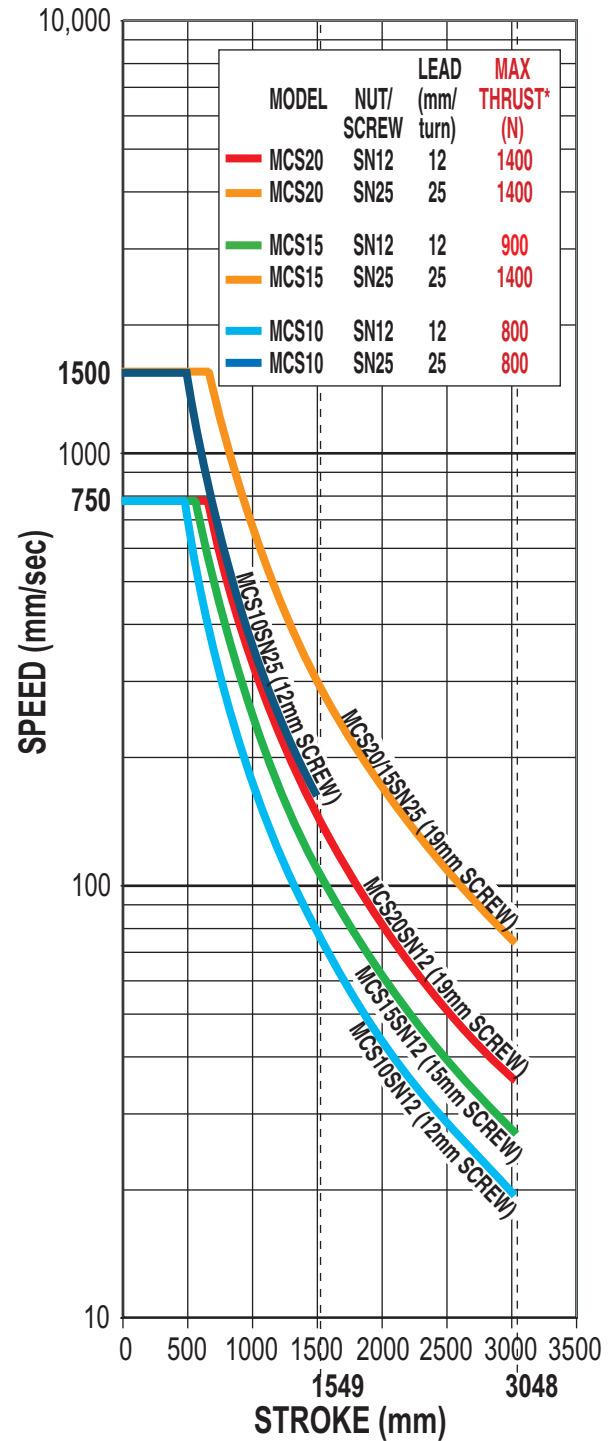

RODLESS

BCS/MCS Series

- Acme critical speed capacities



*Maximum thrust is the maximum continuous dynamic thrust subject to Thrust x Velocity limitation.

Dotted lines represent maximum stroke for screw selections.

For Screw PV limits, refer to the individual charts located in the technical section for each actuator body size.

Axi-dyne® BCS/MCS Screw Drives

BALL SCREW/NUT COMBINATIONS

BALL SCREW CRITICAL SPEED CAPACITIES

CRITICAL SPEED WITH ENGLISH BALL SCREW

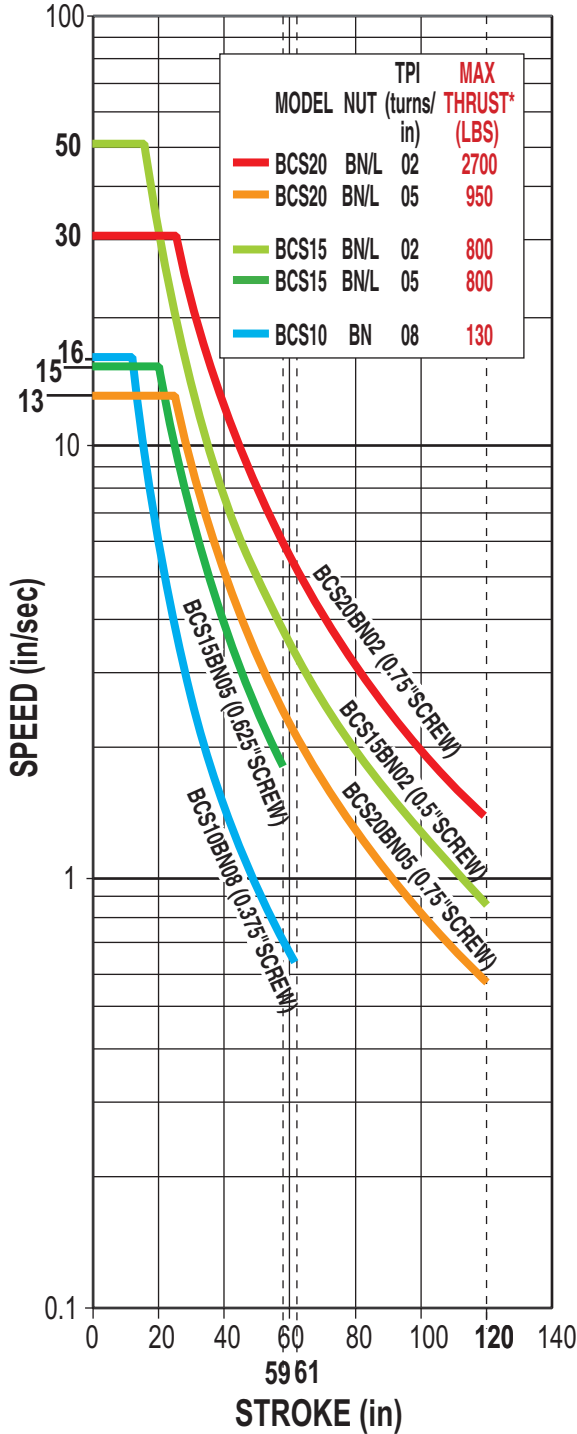

CRITICAL SPEED WITH METRIC BALL SCREW

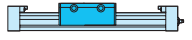
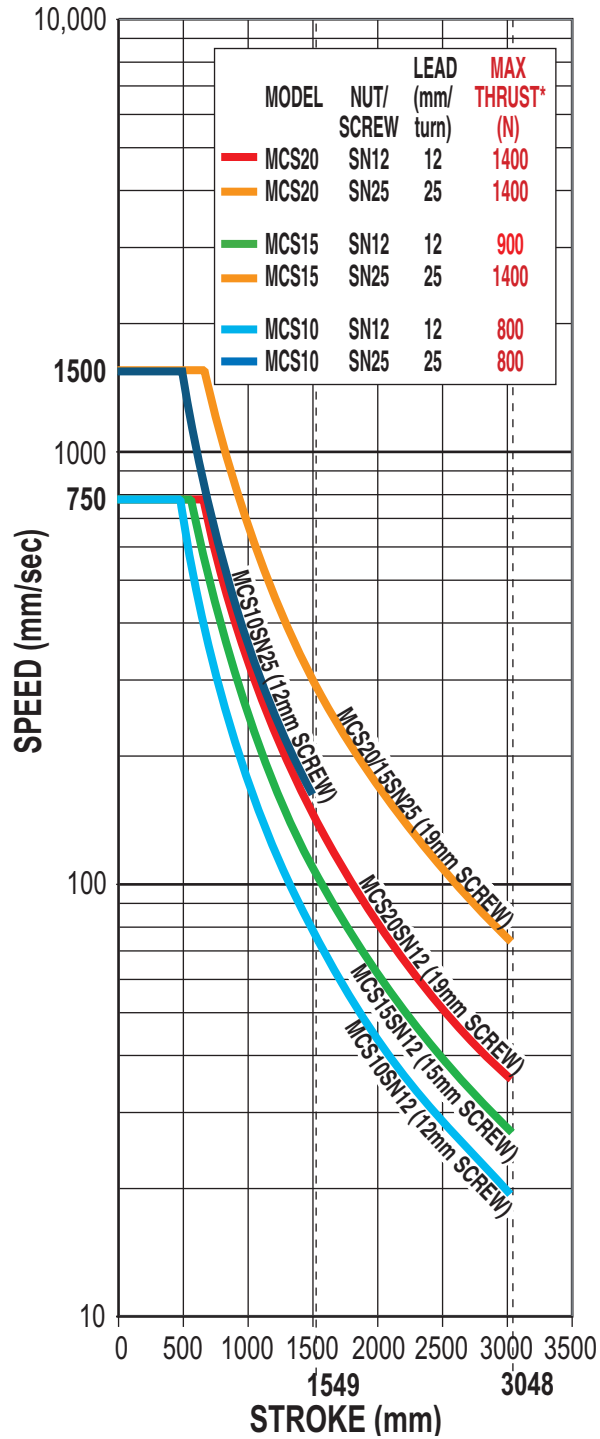

RODLESS

BCS/MCS Series

- Ball screw critical speed capacities



* Maximum thrust reflects 90% reliability for 1 million linear inches of travel.

Dotted lines represent maximum stroke for screw selections.

Refer to the technical section for each actuator body size for details on life calculations for individual screws.

Axi dyne[®] BCS/MCS Screw Drives

BALL SCREW SPECIFICATIONS

BALL SCREW LIFE CALCULATION

LIFE CAPACITIES WITH ENGLISH BALL SCREW

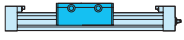
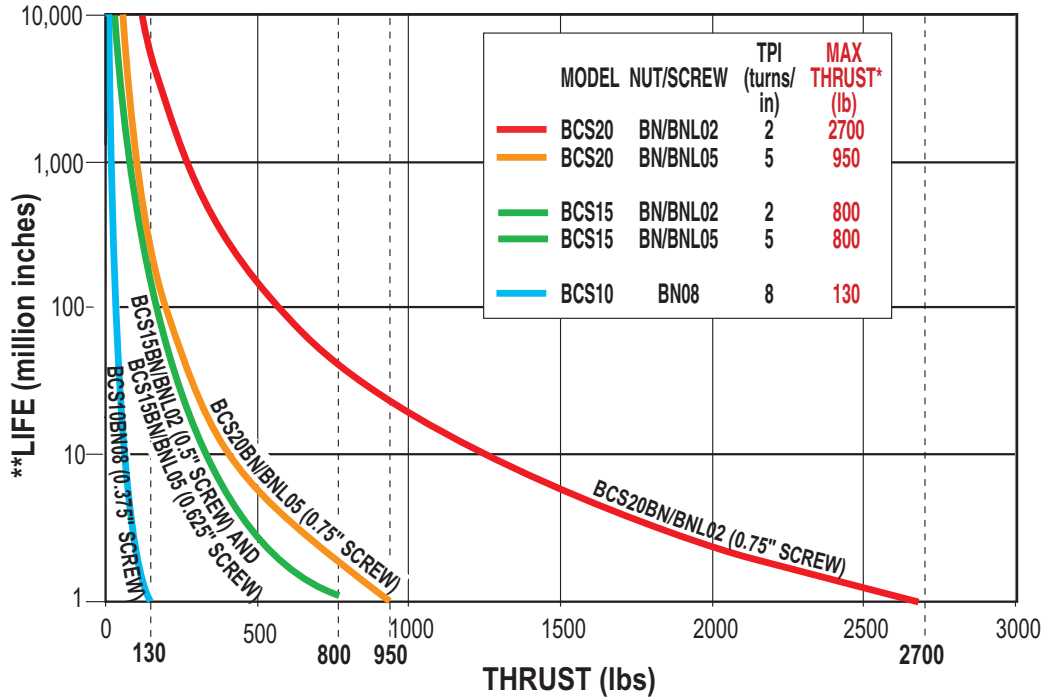

RODLESS

BCS/MCS Series

- Ball screw life calculations

LIFE CAPACITIES WITH METRIC BALL SCREW

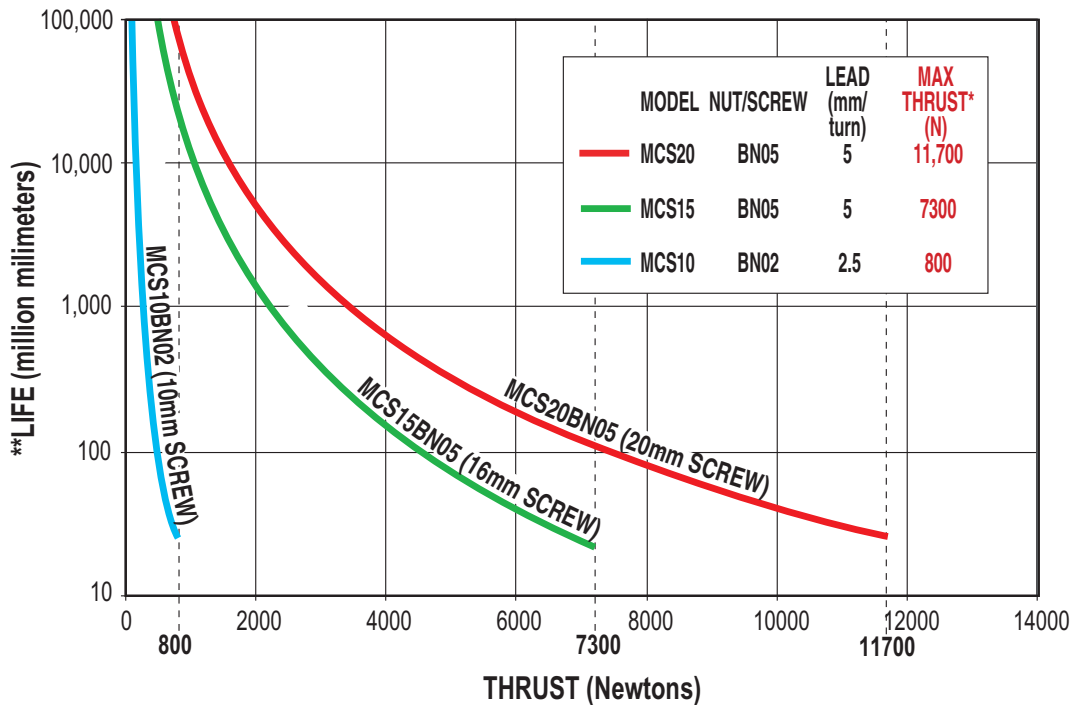

*Maximum thrust reflects 90% reliability for 1 million linear inches of travel.

Dotted lines represent maximum thrust for screw selections.

**Life indicates theoretical maximum life of screw only, under ideal conditions and does not indicate expected life of actuator.

BCS/MCS Screw Drives

OVERALL SERIES SPECIFICATIONS

SPECIFICATIONS RELATED TO ACTUATOR SIZE AND SCREW SELECTION

| ENGLISH LEAD SCREWS | | | | | | | | | | | |
|---------------------|-----------------|------------|----------------|-----------------------|---------------|----------------------|---------------------|-------------------------------|---------------|------------------|--------------------------|
| ACTUATOR SERIES | SCREW DIA. (in) | SCREW TYPE | TPI (turns/in) | LEAD ACCURACY (in/ft) | BACKLASH (in) | MAXIMUM THRUST* (lb) | MAXIMUM STROKE (in) | INERTIA (lb-in ²) | | | BREAKAWAY TORQUE (lb-in) |
| | | | | | | | | BASE ACTUATOR | | PER/in OF STROKE | |
| | | | | | | | | In Line | Rev. Parallel | | |
| BCS10 | 0.375 | BN | 08 | 0.004 | 0.015 | 130 | 61 | 0.0046 | 0.0054 | 0.0005 | 1.000 |
| | 0.375 | BNL | 08 | 0.004 | 0.002 | 130 | 61 | 0.0046 | 0.0054 | 0.0005 | 1.000 |
| | 0.500 | SN | 01 | 0.006 | 0.007 | 170 | 85 | 0.0321 | 0.0348 | 0.0017 | 1.857 |
| | 0.500 | SN | 02 | 0.005 | 0.007 | 170 | 120 | 0.0190 | 0.0217 | 0.0017 | 1.563 |
| | 0.500 | SNA | 02 | 0.005 | 0.003 | 170 | 120 | 0.0190 | 0.0217 | 0.0017 | 1.563 |
| | 0.500 | SN | 05 | 0.006 | 0.007 | 170 | 120 | 0.0153 | 0.0180 | 0.0017 | 1.125 |
| BCS15 | 0.500 | BN | 02 | 0.003 | 0.015 | 800 | 59 | 0.0299 | 0.0327 | 0.0017 | 1.375 |
| | 0.500 | BNL | 02 | 0.003 | 0.002 | 800 | 59 | 0.0299 | 0.0327 | 0.0017 | 1.375 |
| | 0.625 | BN | 05 | 0.003 | 0.015 | 800 | 59 | 0.0455 | 0.0524 | 0.0042 | 1.188 |
| | 0.625 | BNL | 05 | 0.003 | 0.002 | 800 | 59 | 0.0455 | 0.0524 | 0.0042 | 1.188 |
| | 0.625 | SN | 02 | 0.005 | 0.007 | 200 | 120 | 0.0558 | 0.0627 | 0.0042 | 1.563 |
| | 0.750 | SN | 01 | 0.005 | 0.007 | 300 | 120 | 0.1391 | 0.1536 | 0.0087 | 2.188 |
| BCS20 | 0.750 | BN | 02 | 0.004 | 0.015 | 2700 | 120 | 0.1241 | 0.1374 | 0.0087 | 1.750 |
| | 0.750 | BNL | 02 | 0.004 | 0.002 | 2700 | 120 | 0.1241 | 0.1374 | 0.0087 | 1.750 |
| | 0.750 | BN | 05 | 0.003 | 0.015 | 950 | 120 | 0.1091 | 0.1224 | 0.0087 | 1.563 |
| | 0.750 | BNL | 05 | 0.003 | 0.002 | 950 | 120 | 0.1091 | 0.1224 | 0.0087 | 1.563 |
| | 0.750 | SN | 01 | 0.005 | 0.007 | 300 | 120 | 0.1775 | 0.1908 | 0.0087 | 3.125 |
| | 0.750 | SN | 02 | 0.005 | 0.007 | 300 | 120 | 0.1241 | 0.1374 | 0.0087 | 2.188 |

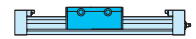

RODLESS

BCS/MCS Series

- Actuator size/screw specifications

| METRIC LEAD SCREWS | | | | | | | | | | | |
|--------------------|-----------------|------------|----------------|------------------------|---------------|---------------------|---------------------|---|---------------|------------------|------------------------|
| ACTUATOR SERIES | SCREW DIA. (mm) | SCREW TYPE | LEAD (mm/turn) | LEAD ACCURACY (mm/300) | BACKLASH (mm) | MAXIMUM THRUST* (N) | MAXIMUM STROKE (mm) | INERTIA (kg-m ² x 10 ⁻⁴) | | | BREAKAWAY TORQUE (N-m) |
| | | | | | | | | BASE ACTUATOR | | PER/mm OF STROKE | |
| | | | | | | | | In Line | Rev. Parallel | | |
| MCS10 | 10 | BN | 2.5 | 0.13 | 0.38 | 800 | 1549 | 1.58 | 1.87 | 0.176 | 0.13 |
| | 10 | BNL | 2.5 | 0.13 | 0.05 | 800 | 1549 | 1.58 | 1.87 | 0.176 | 0.13 |
| | 12 | SN | 12 | 0.13 | 0.18 | 800 | 3048 | 4.53 | 5.18 | 0.410 | 0.20 |
| | 12 | SN | 25 | 0.13 | 0.18 | 800 | 1626 | 8.34 | 8.98 | 0.410 | 0.28 |
| MCS15 | 15 | SN | 12 | 0.13 | 0.18 | 900 | 3048 | 13.22 | 14.83 | 0.966 | 0.27 |
| | 16 | BN | 5 | 0.13 | 0.38 | 7300 | 1499 | 13.69 | 15.77 | 1.258 | 0.16 |
| | 16 | BNL | 5 | 0.13 | 0.05 | 7300 | 1499 | 13.69 | 15.77 | 1.258 | 0.16 |
| | 19 | SN | 25 | 0.13 | 0.18 | 1400 | 3048 | 39.98 | 44.17 | 2.517 | 0.32 |
| MCS20 | 19 | SN | 12 | 0.13 | 0.18 | 1400 | 3048 | 35.42 | 39.28 | 2.517 | 0.39 |
| | 19 | SN | 25 | 0.13 | 0.18 | 1400 | 3048 | 50.95 | 54.81 | 2.517 | 0.57 |
| | 20 | BN | 5 | 0.13 | 0.38 | 11700 | 3048 | 38.61 | 43.32 | 3.102 | 0.25 |
| | 20 | BNL | 5 | 0.13 | 0.05 | 11700 | 3048 | 38.61 | 43.32 | 3.102 | 0.25 |

| SCREW CODE | DESCRIPTION |
|------------|-------------------------|
| SN | Solid Nut |
| SNA | Anti-backlash Solid Nut |
| BN | Ball Nut |
| BNL | Low-Backlash Ball Nut |



Contact the factory for higher accuracy and lower backlash options.

* For Acme screws, maximum thrust is the maximum continuous dynamic thrust subject to Thrust x Velocity limitation.

For ball screws, maximum thrust reflects 90% reliability for 1 million linear inches of travel.

Axi-dyne® BCS/MCS Screw Drives

OVERALL SERIES SPECIFICATIONS

GENERAL ACTUATOR SPECIFICATIONS

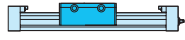

RODLESS

BCS/MCS Series

- General actuator specifications
- Friction force
- Support recommendations

| BCS ENGLISH ACTUATORS | | | | | |
|-----------------------|---------------------|---|------------------------------|-------------------------|-------------|
| ACTUATOR SERIES | CARRIER WEIGHT (lb) | BASE WEIGHT (lb) (Including Carrier) | WEIGHT PER/IN OF STROKE (lb) | TEMPERATURE RANGE* (F°) | IP RATING** |
| BCS10 | 0.69 | 2.91 | 0.176 | 40 - 130 | 44 |
| BCS15 | 1.94 | 6.61 | 0.392 | 40 - 130 | 44 |
| BCS20 | 2.81 | 14.59 | 0.666 | 40 - 130 | 44 |

| MCS METRIC ACTUATORS | | | | | |
|----------------------|---------------------|---|-----------------------------|-------------------------|-------------|
| ACTUATOR SERIES | CARRIER WEIGHT (kg) | BASE WEIGHT (kg) (Including Carrier) | WEIGHT PER/mm OF STROKE (g) | TEMPERATURE RANGE* (C°) | IP RATING** |
| MCS10 | 0.31 | 1.32 | 3.1 | 4 - 54 | 44 |
| MCS15 | 0.88 | 2.90 | 7.0 | 4 - 54 | 44 |
| MCS20 | 1.27 | 6.62 | 11.9 | 4 - 54 | 44 |



* Heat generated by the motor and drive should be taken into consideration as well as linear velocity and work cycle time. For applications that require operation outside of the recommended temperature range, contact the factory.

** Protected against ingress of solid particles greater than .039 in (1mm) and splashing water

LARGE FRAME MOTORS AND SMALLER SIZE ACTUATORS: Cantilevered motors need to be supported, if subjected to continuous rapid reversing duty and/or under dynamic conditions.

BCS CARRIER BRACKET BOLT ADJUSTMENT (ALL SIZES)



BCS carrier bracket adjustment bolts should be adjusted to suit each individual application, depending on the degree of rigidity required. A good starting point is to tighten the nut on the bolt until there is no lateral movement of the bolt.

Then, equally tighten each nut on the carrier bolt while moving the carrier by hand along the length of the stroke. When all lateral play in the carrier is eliminated and free movement along the length of the stroke is maintained, your carrier bracket is adjusted properly. Some applications may require fine tuning of this adjustment to gain more lateral play or a higher degree of rigidity. In demanding applications, carrier adjustments should be done periodically.

***CAUTION:**



Over-tightening increases drive torque of motor and drive.

FRICITION FORCE

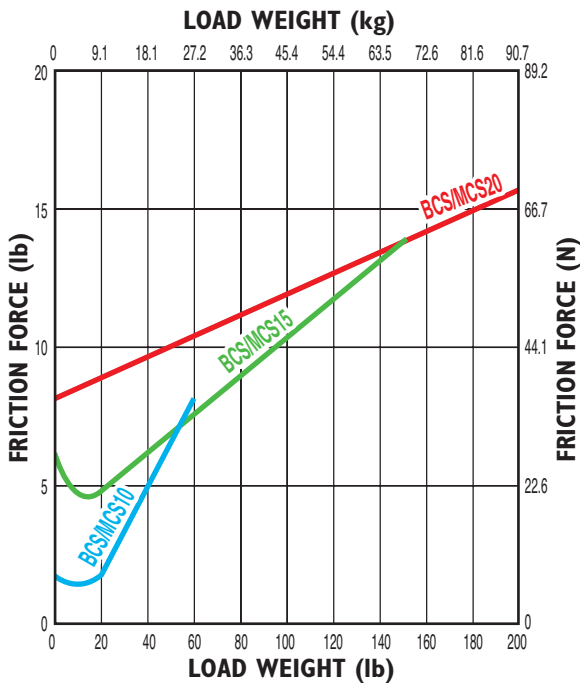

SUPPORT RECOMMENDATIONS

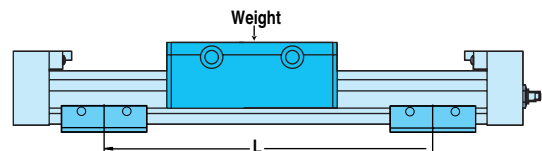
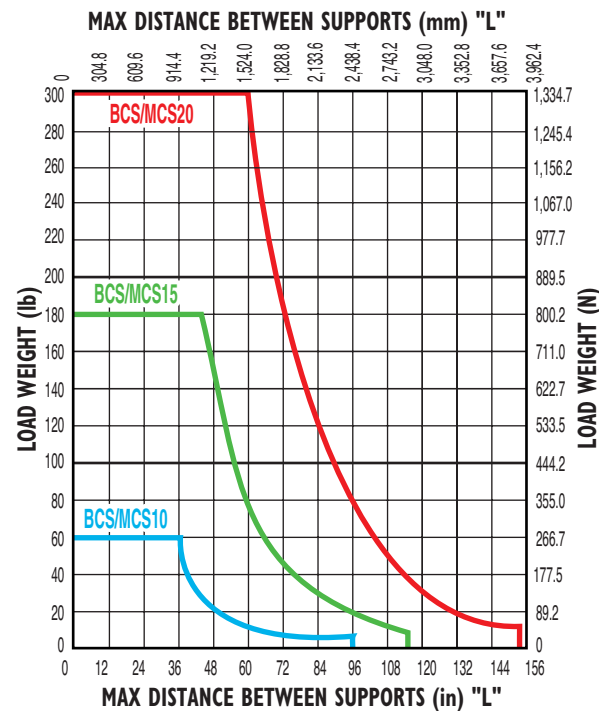

Axi-dyne® BCS/MCS Screw Drives

OVERALL SERIES SPECIFICATIONS

DYNAMIC BENDING MOMENTS AND LOADS

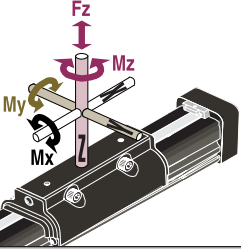
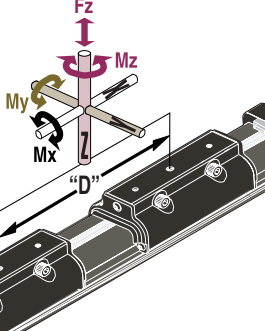
| STANDARD CARRIER | | MAXIMUM BENDING MOMENTS AND LOADS | | | ENGLISH | | | METRIC | | |
|--|-----------------------|-----------------------------------|-------|-------|---------|-------|-------|--------|--|--|
| | | BCS10 | BCS15 | BCS20 | MCS10 | MCS15 | MCS20 | | | |
|  | Mx Moment (Roll) | (lb-in : N-m) | 55 | 275 | 300 | 6.2 | 31.1 | 33.9 | | |
| | My Moment (Pitch) | (lb-in : N-m) | 100 | 500 | 1100 | 11.3 | 56.5 | 124.3 | | |
| | Mz Moment (Yaw) | (lb-in : N-m) | 30 | 200 | 325 | 3.4 | 22.6 | 36.7 | | |
| | Fz Load (Lateral) | (lb : N) | 60 | 180 | 300 | 267 | 801 | 1335 | | |
| AUXILIARY CARRIER: Increases rigidity, load-carrying capacity and moments | | BCS10 | BCS15 | BCS20 | MCS10 | MCS15 | MCS20 | | | |
|  | Mx Moment (Roll) | *(lb-in : N-m) | 110 | 550 | 600 | 12.4 | 62.1 | 67.8 | | |
| | My Moment (Pitch) | *(lb-in : N-m) | 287 | 1453 | 2430 | 32.4 | 164.1 | 274.6 | | |
| | Mz Moment (Yaw) | *(lb-in : N-m) | 287 | 1453 | 2430 | 32.4 | 164.1 | 274.6 | | |
| | Fz Load (Lateral) | (lb : N) | 120 | 360 | 600 | 534 | 1602 | 2670 | | |
| | Minimum Dimension 'D' | (in : mm) | 5.10 | 6.50 | 8.10 | 129.5 | 165.0 | 206.0 | | |

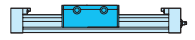

RODLESS

BCS/MCS Series

- Bending moments and loads
- Auxiliary carrier

! Please see *BCS Carrier Bracket Bolt Adjustment* on page C-108

! Breakaway torque will increase when using the Auxiliary carrier option. When ordering, determine your working stroke and enter this value into the configuration string. Overall actuator length will automatically be calculated.

*Loads shown in table are at minimum "D" dimension, for ratings with longer "D" dimension see graph below.

AUXILIARY CARRIER: BENDING MOMENT AT 'D' DISTANCE

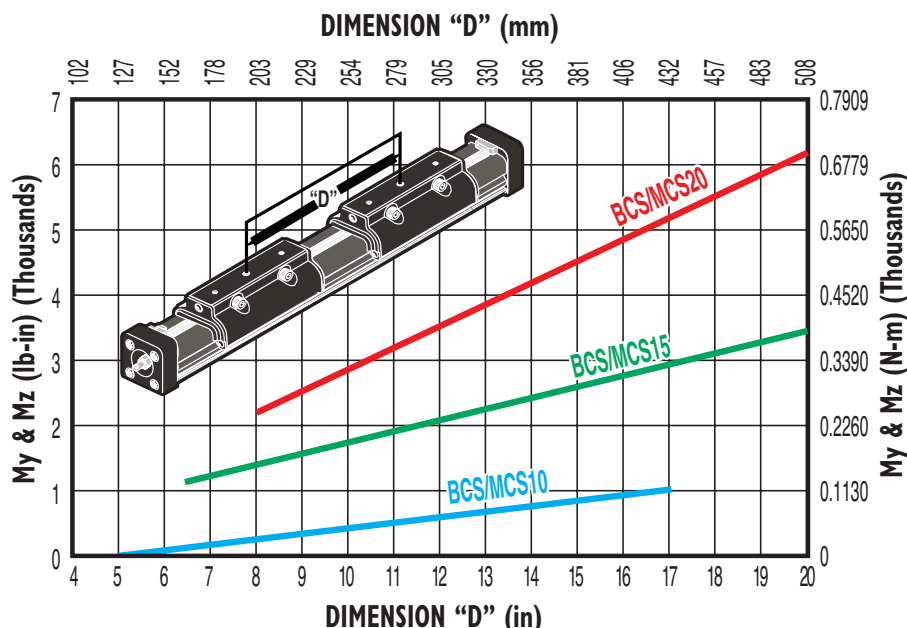

Rates shown on charts were calculated with these assumptions:

- 1.) Coupling between carriers is rigid.
- 2.) Load is equally distributed between carriers.

3.) Coupling device applies no misalignment loads to carriers.

* Customer must specify Dimension "D" (Distance between carrier center lines) in configuration string.

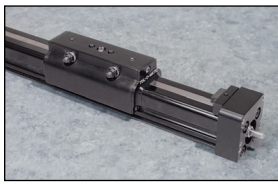

Axi
dyne[®]

BCS/MCS10 Series ACME SCREW SPECIFICATIONS

BCS10/MCS10 ACME SCREW CRITICAL SPEED AND PV LIMITS

CRITICAL SPEED WITH 1/2" ENGLISH ACME SCREW

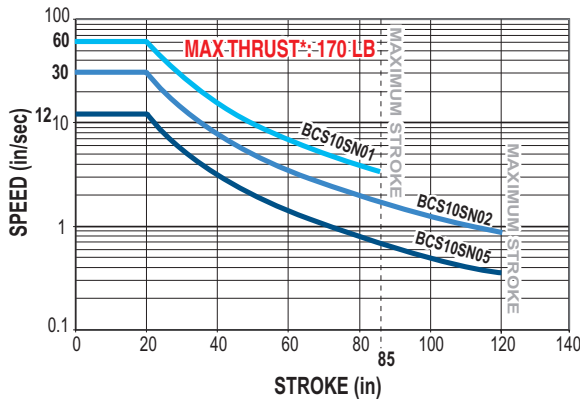

CRITICAL SPEED WITH 12mm METRIC ACME SCREW

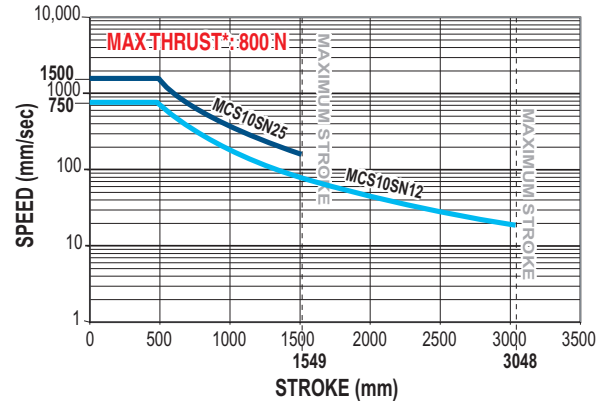

PV LIMITS: 1/2" 1 TPI ENGLISH ACME SCREW

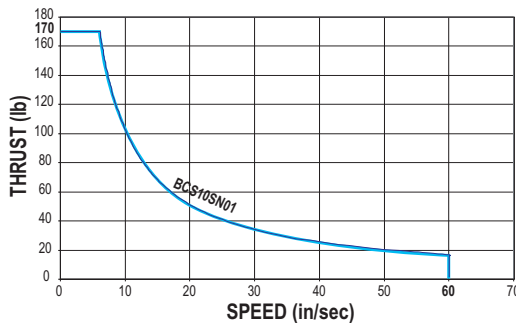

PV LIMITS: 12mm ACME METRIC SCREW w/25mm LEAD

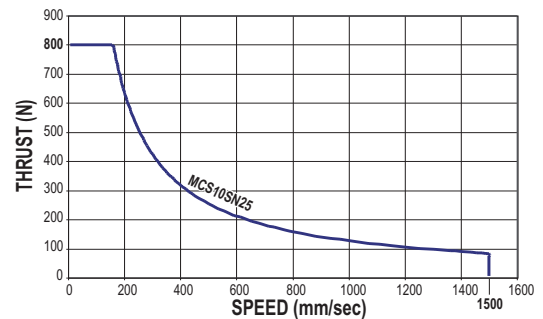

PV LIMITS: 1/2" 2 TPI ENGLISH ACME SCREW

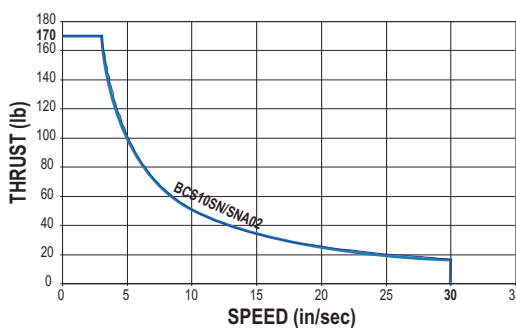

PV LIMITS: 12mm ACME METRIC SCREW w/12mm LEAD

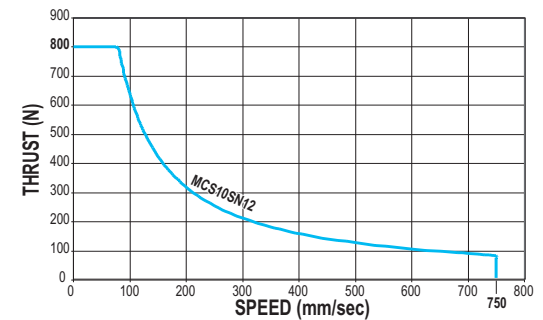

PV LIMITS: 1/2" 5 TPI ENGLISH ACME SCREW

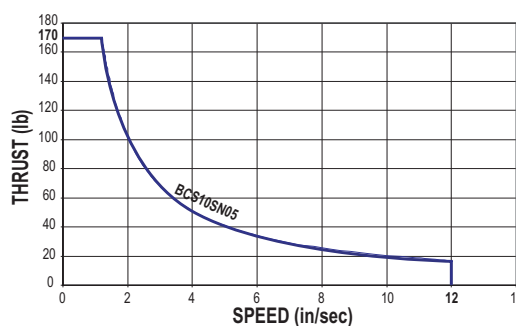

SN = Solid Nut

SNA = Solid Anti-backlash Nut

⚠️ *Maximum thrust is the maximum continuous dynamic thrust subject to Thrust x Velocity limitation.

PV LIMITS: Any material which carries a sliding load is limited by heat buildup. The factors that affect heat generation rate in an application are the pressure on the nut in pounds per square inch and the surface velocity in feet per minute. The product of these factors provides a measure of the severity of an application.

$$P = \frac{\text{Thrust}}{\text{Max. Thrust Rating}} \times V = \frac{\text{Speed}}{\text{Max. Speed Rating}} \leq 0.1$$

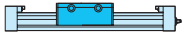

RODLESS

BCS/MCS10 Series

- Acme screw critical speed capacities and PV limits

Axi-dyne® BCS/MCS10 Series

BALL SCREW SPECIFICATIONS

BCS/MCS10 BALL SCREW SPECIFICATIONS

CRITICAL SPEED WITH 3/8" ENGLISH BALL SCREW

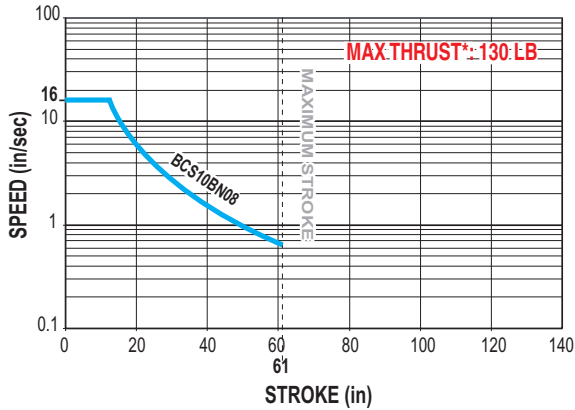

CRITICAL SPEED WITH 10mm METRIC BALL SCREW

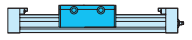
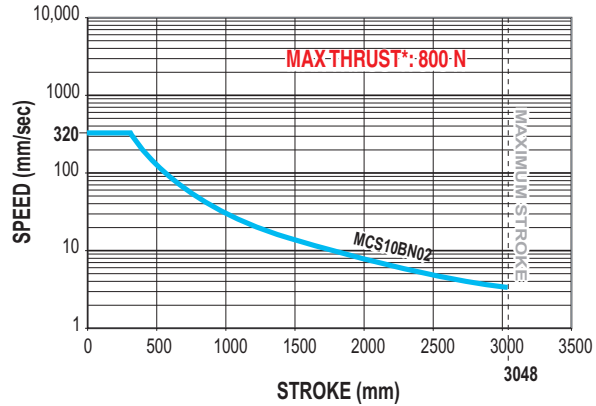

RODLESS

BCS/MCS10 Series

- Ball screw critical speed capacities and life calculations

LIFE CALCULATION: 3/8" 8TPI ENGLISH BALL SCREW

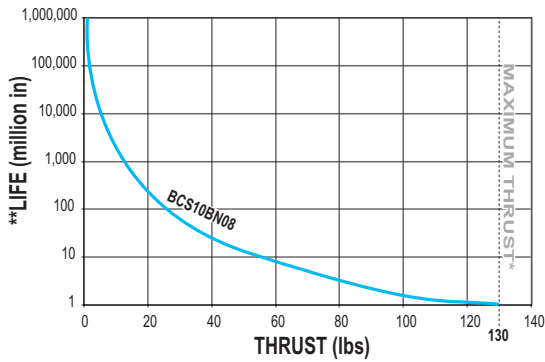

LIFE CALCULATION: 10mm METRIC BALL SCREW w/2.5mm LEAD

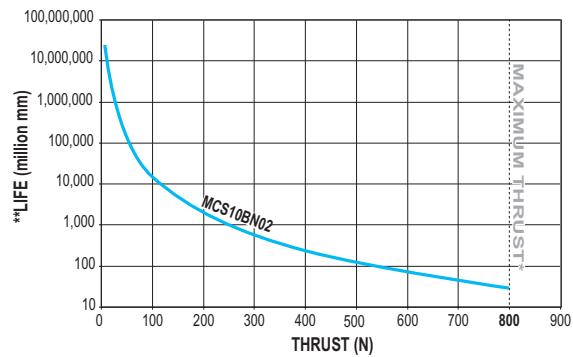

BN = Ball Nut



*Maximum thrust reflects 90% reliability for 1 million linear inches of travel.

**Life indicates theoretical maximum life of screw only, under ideal conditions and does not indicate expected life of actuator.

Axi-dyne[®] BCS/MCS10 Series

DIMENSIONS

BCS10/MCS10 ACTUATOR AND OPTIONS

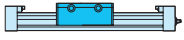

RODLESS

BCS/MCS10 Series

• Actuator and options dimensions

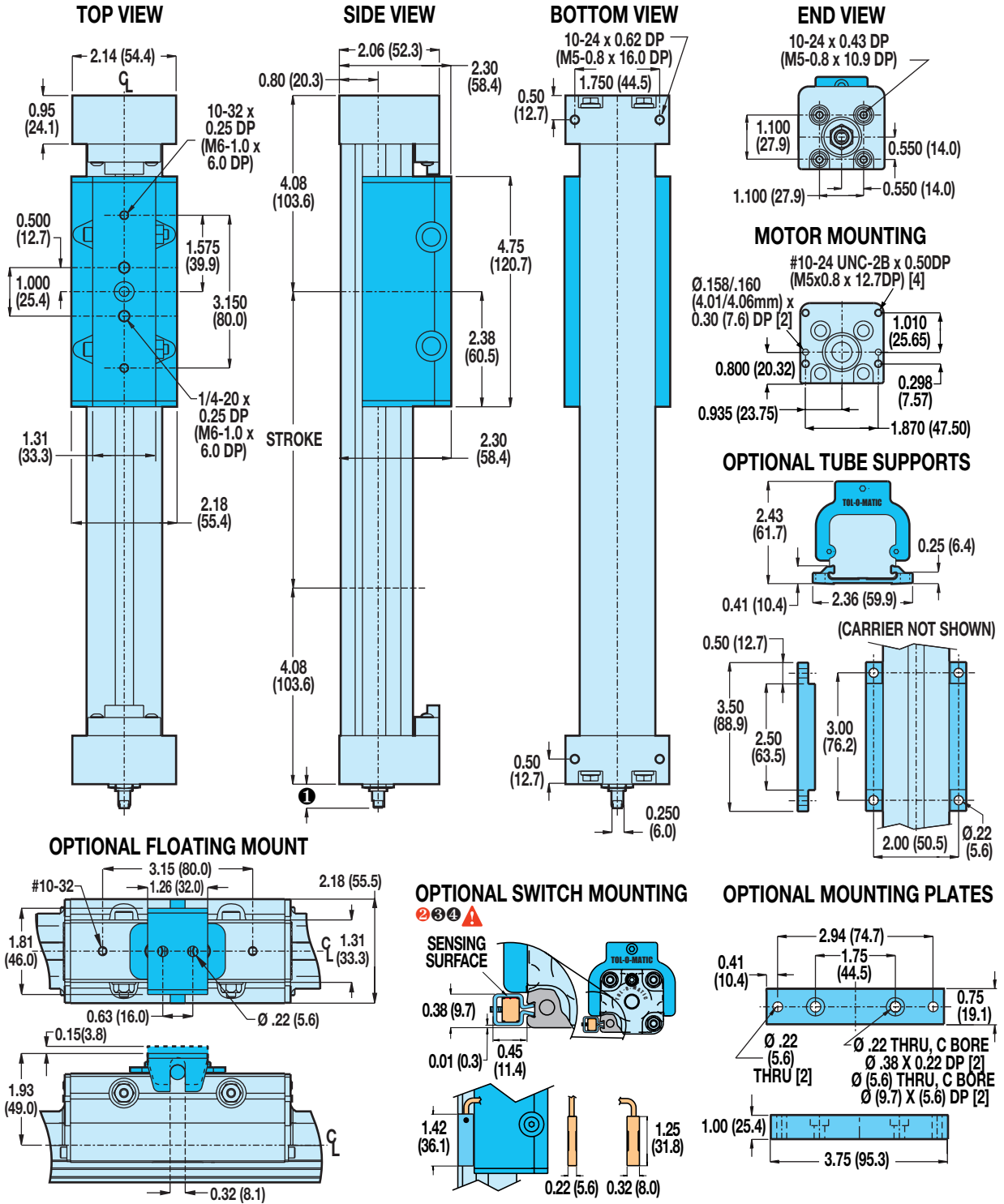

① SHAFT LENGTH

| | |
|---|-------------|
| In-line mounting | 0.53 (13.5) |
| Extended shaft for RP & 23-frame motor | 1.89 (48.0) |
| Extended shaft for RP & 34-frame motor | 2.10 (53.3) |
| Extended shaft for purchases prior to 6/24/02 | 1.53 (38.9) |

⚠ CAUTION: DO NOT OVERTIGHTEN SWITCH HARDWARE WHEN INSTALLING

② NOTE: The scored face of the switch indicates the sensing surface and must face toward the magnet

④ NOTE: Some actuators require switch mounting on a specific side of the actuator. Call Tol-O-Matic 1-800-328-2174 for details

Unless otherwise noted, all dimensions shown are in inches (Dimensions in parenthesis are in millimeters)

Axi-dyne® BCS/MCS10 Series

DIMENSIONS

BCS/MCS10: IN-LINE MOUNT FOR MOTORS OR GEARHEADS

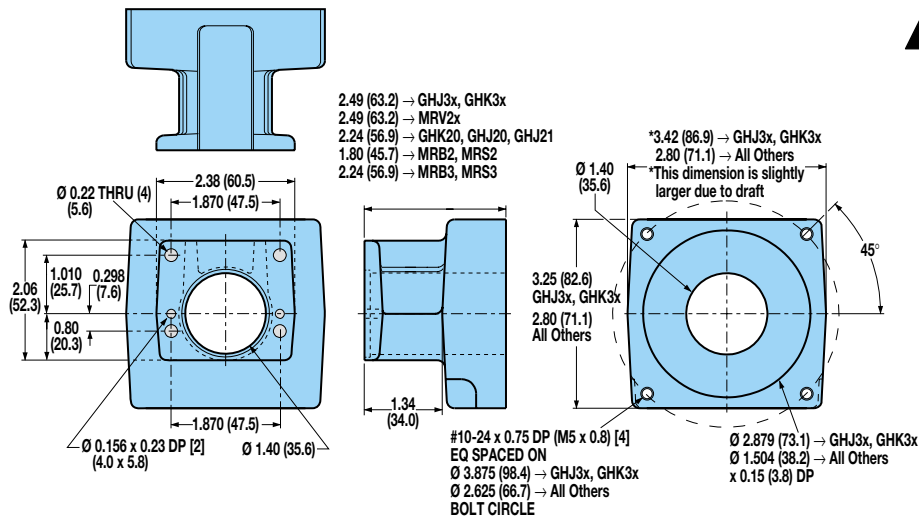

! For gearhead dimensions and specifications, refer to page F-10.

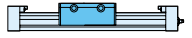

RODLESS

BCS/MCS10 Series

- In-line motor mounting
- Reverse parallel mounting

BCS/MCS10: REVERSE PARALLEL MOUNTING

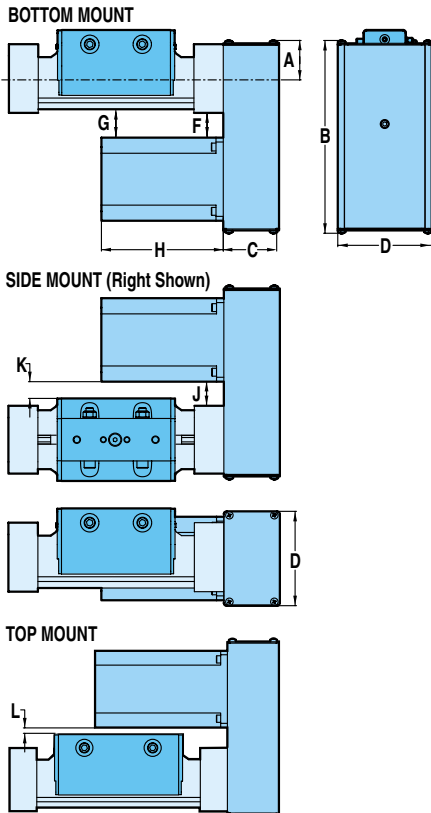

SPECIFICATIONS

| MOTOR | WEIGHT OF REDUCTION DRIVE | | | | REDUCTION INERTIA AT MOTOR SHAFT | | | |
|------------------------------------|---------------------------|--------|------|-------|----------------------------------|--------------------|--------------------|--------------------|
| | 1:1 | | 2:1 | | 1:1 | | 2:1 | |
| | lbs | kg | lbs | kg | lb-in ² | kg-cm ² | lb-in ² | kg-cm ² |
| BRUSHLESS MRV21, 22, 23, 24 | 2.06 | 0.9344 | 2.06 | .9344 | .070 | .2043 | .095 | .2767 |

REDUCTION EFFICIENCY: 0.95

DIMENSIONS

| MOTOR | A | | B | | C | | D | | F | | G | | H | | J | | K | | L | |
|------------------------|------|------|------|-------|------|------|------|------|------|------|------|------|------|-------|------|------|------|------|------|------|
| | in. | mm | in. | mm | in. | mm | in. | mm | in. | mm | in. | mm | in. | mm | in. | mm | in. | mm | in. | mm |
| BRUSHLESS MRV21 | 1.44 | 36.6 | 6.96 | 176.7 | 2.13 | 54.0 | 3.25 | 82.6 | 1.81 | 45.9 | 1.83 | 46.5 | 4.75 | 120.7 | 1.54 | 39.1 | 1.83 | 46.5 | 1.11 | 28.2 |
| MRV22 | 1.44 | 36.6 | 6.96 | 176.7 | 2.13 | 54.0 | 3.25 | 82.6 | 1.81 | 45.9 | 1.83 | 46.5 | 5.75 | 146.1 | 1.54 | 39.1 | 1.83 | 46.5 | 1.11 | 28.2 |
| MRV23 | 1.44 | 36.6 | 6.96 | 176.7 | 2.13 | 54.0 | 3.25 | 82.6 | 1.81 | 45.9 | 1.83 | 46.5 | 6.75 | 171.5 | 1.54 | 39.1 | 1.83 | 46.5 | 1.11 | 28.2 |
| MRV24 | 1.44 | 36.6 | 6.96 | 176.7 | 2.13 | 54.0 | 3.25 | 82.6 | 1.81 | 45.9 | 1.83 | 46.5 | 7.75 | 196.9 | 1.54 | 39.1 | 1.83 | 46.5 | 1.11 | 28.2 |

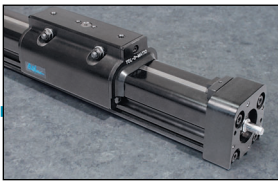

Axi-dyne[®] BCS/MCS15 Series ACME SCREW SPECIFICATIONS

BCS15 ENGLISH ACME SCREW SPECIFICATIONS

CRITICAL SPEED WITH 5/8" ENGLISH ACME SCREW

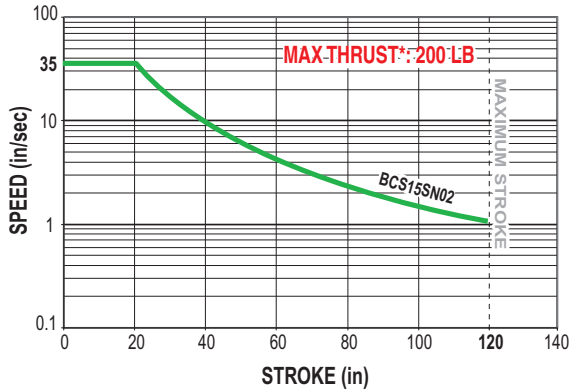

CRITICAL SPEED WITH 3/4" ENGLISH ACME SCREW

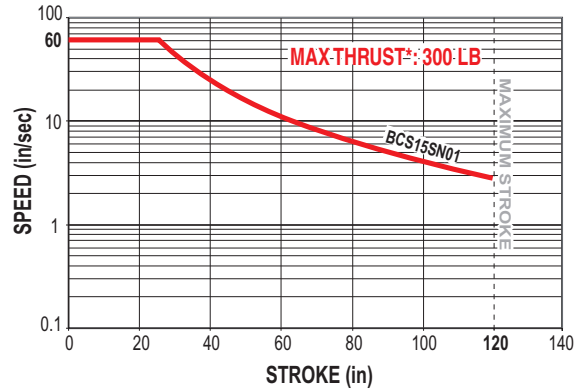

PV LIMITS: 5/8" 2TPI ENGLISH ACME SCREW

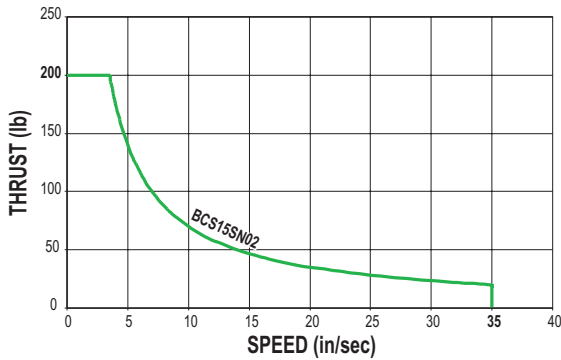

PV LIMITS: 3/4" 1TPI ENGLISH ACME SCREW

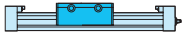
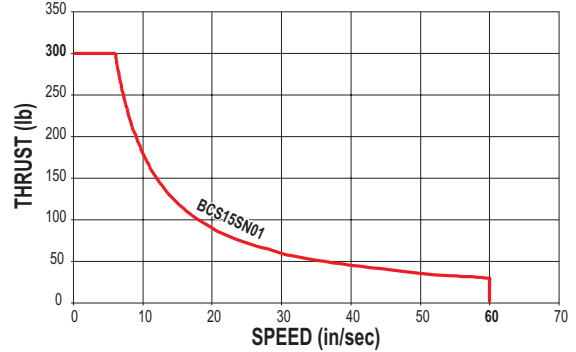

RODLESS

BCS/MC15S Series

- English acme screw critical speed capacities and PV limits

SN = Solid Nut

SNA = Solid Anti-backlash Nut



**Maximum thrust is the maximum continuous dynamic thrust subject to Thrust x Velocity limitation.*

PV LIMITS: Any material which carries a sliding load is limited by heat buildup. The factors that affect heat generation rate in an application are the pressure on the nut in pounds per square inch and the surface velocity in feet per minute. The product of these factors provides a measure of the severity of an application.

$$P = \frac{\text{Thrust}}{\text{Max. Thrust Rating}} \times V = \frac{\text{Speed}}{\text{Max. Speed Rating}} \leq 0.1$$

Axi-dyne® BCS/MCS15 Series

ACME SCREW SPECIFICATIONS

MCS15 METRIC ACME SCREW SPECIFICATIONS

CRITICAL SPEED WITH 15mm METRIC ACME SCREW

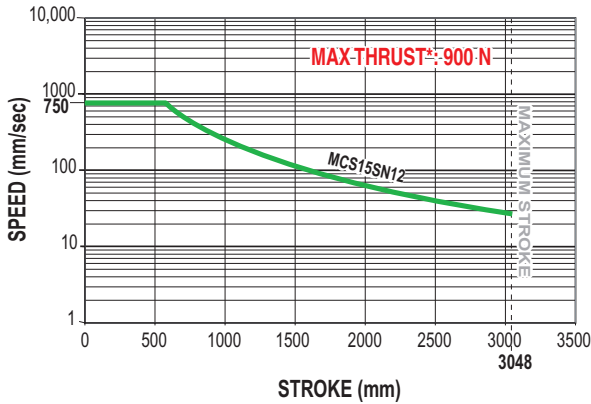

CRITICAL SPEED WITH 19mm METRIC ACME SCREW

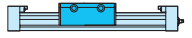
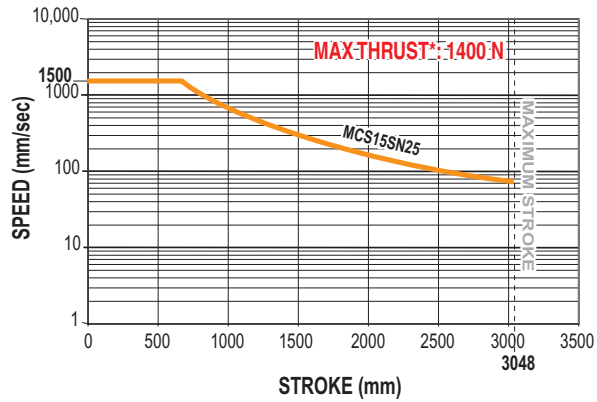

RODLESS

BCS/MCS15 Series

- Metric acme screw critical speed capacities and PV limits

PV LIMITS: 15mm METRIC ACME SCREW w/12mm LEAD

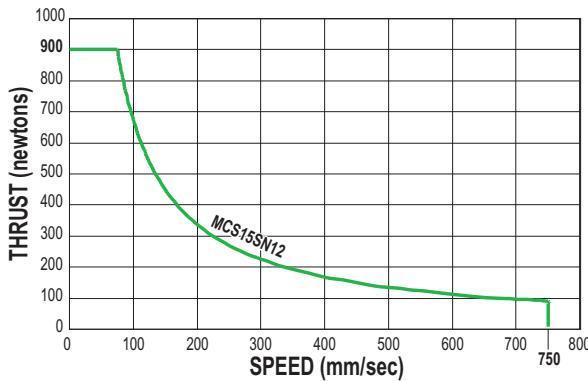

PV LIMITS: 19mm METRIC ACME SCREW w/25mm LEAD

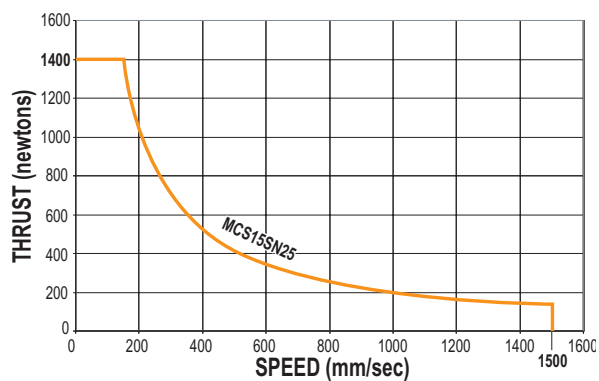

SN = Solid Nut



* Maximum thrust is the maximum continuous dynamic thrust subject to Thrust x Velocity limitation.

PV LIMITS: Any material which carries a sliding load is limited by heat buildup. The factors that affect heat generation rate in an application are the pressure on the nut in pounds per square inch and the surface velocity in feet per minute. The product of these factors provides a measure of the severity of an application.

$$P = \frac{\text{Thrust}}{\text{Max. Thrust Rating}} \times V = \frac{\text{Speed}}{\text{Max. Speed Rating}} \leq 0.1$$

Axi-dyne® BCS/MCS15 Series

BALL SCREW SPECIFICATIONS

BCS/MCS15 BALL SCREW SPECIFICATIONS

CRITICAL SPEED WITH 1/2" ENGLISH BALL SCREW

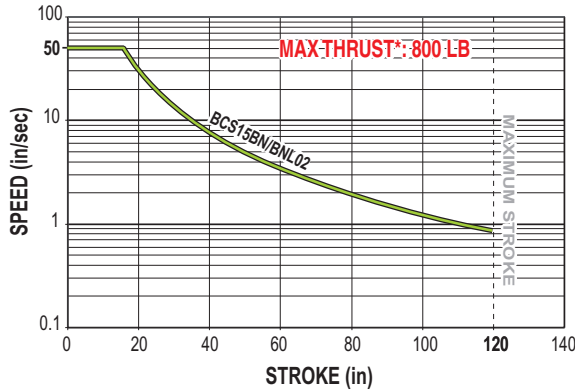

CRITICAL SPEED WITH 16mm METRIC BALL SCREW

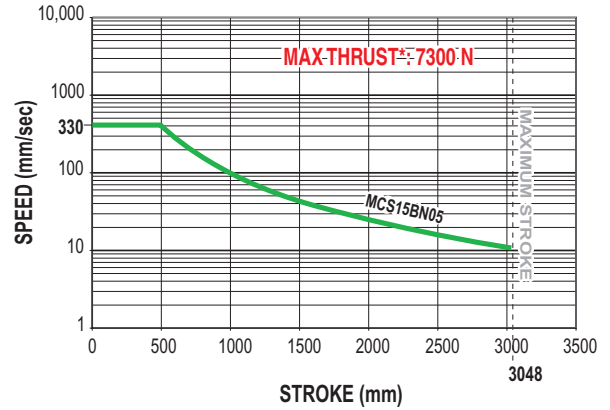

CRITICAL SPEED WITH 5/8" ENGLISH BALL SCREW

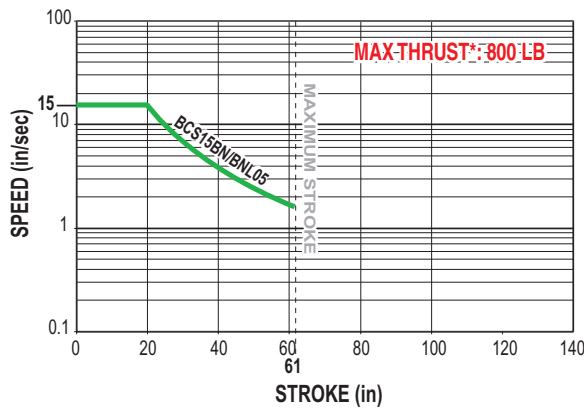

LIFE CALCULATION: 16mm METRIC BALL SCREW w/5mm LEAD

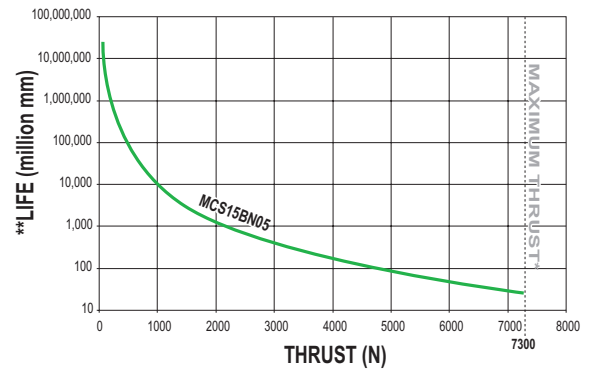

LIFE CALCULATION: 1/2" w/2TPI & 5/8" w/5TPI ENGLISH BALL SCREW

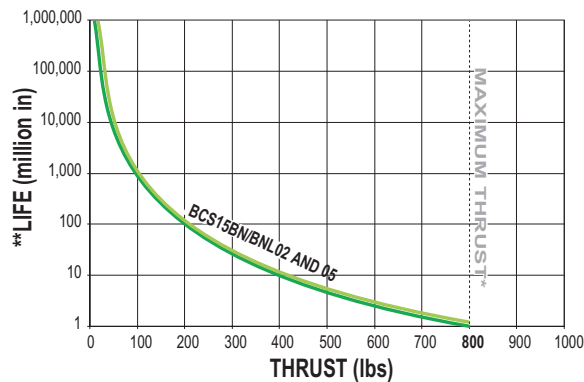

BN = Ball Nut

BNL = Ball Nut with Low-Backlash



* Maximum thrust reflects 90% reliability for 1 million linear inches of travel.

**Life indicates theoretical maximum life of screw only, under ideal conditions and does not indicate expected life of actuator.

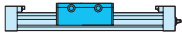

RODLESS

BCS/MCS15 Series

- Ball screw critical speed capacities and life calculations

Axi-dyne® BCS/MCS15 Series

DIMENSIONS

BCS15/MCS15 ACTUATOR AND OPTIONS

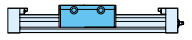
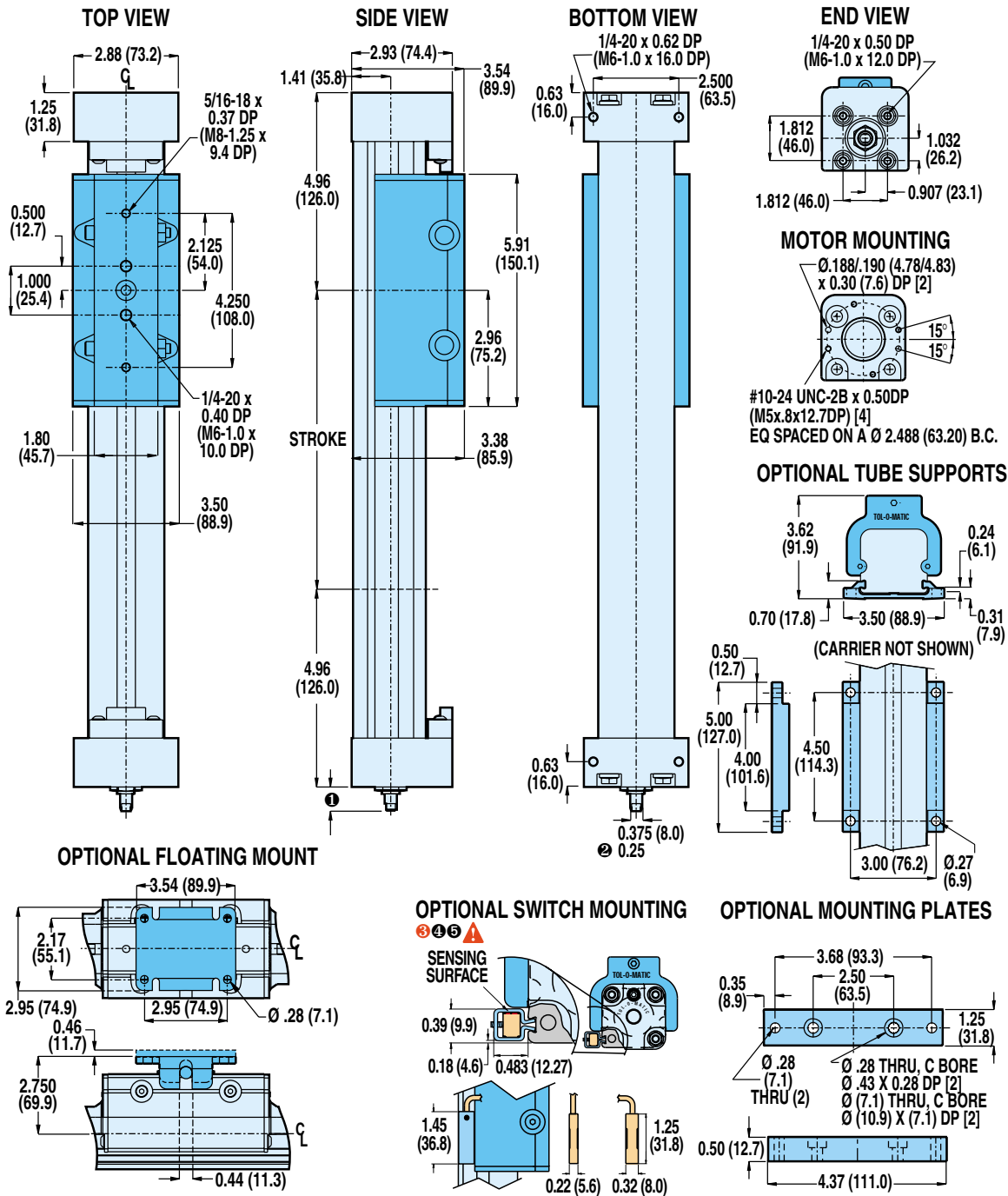

RODLESS

BCS/MCS15 Series

- Actuator and options dimensions

① SHAFT LENGTH

| | |
|---|-------------|
| In-line mounting | 0.65 (16.5) |
| Extended shaft for RP & 23-frame motor | 1.94 (49.3) |
| Extended shaft for RP & 34-frame motor | 2.15 (54.6) |
| Extended shaft for RP & 40-frame motor | 2.31 (58.7) |
| Extended shaft for purchases prior to 6/24/02 | 1.90 (48.2) |

② FOR 1/2" 2TPI BALL-SCREW STYLE ONLY

⚠ CAUTION: DO NOT OVERTIGHTEN SWITCH HARDWARE WHEN INSTALLING

④ NOTE: The scored face of the switch indicates the sensing surface and must face toward the magnet

⑤ NOTE: Some actuators require switch mounting on a specific side of the actuator. Call Tol-O-Matic 1-800-328-2174 for details

Unless otherwise noted, all dimensions shown are in inches (Dimensions in parenthesis are in millimeters)

Axi-dyne® BCS/MCS15 Series

DIMENSIONS

BCS/MCS15: IN-LINE MOUNT FOR MOTORS AND GEARHEADS

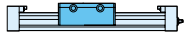

RODLESS

BCS/MCS15 Series

- In-line motor mounting
- Reverse parallel mounting dimensions

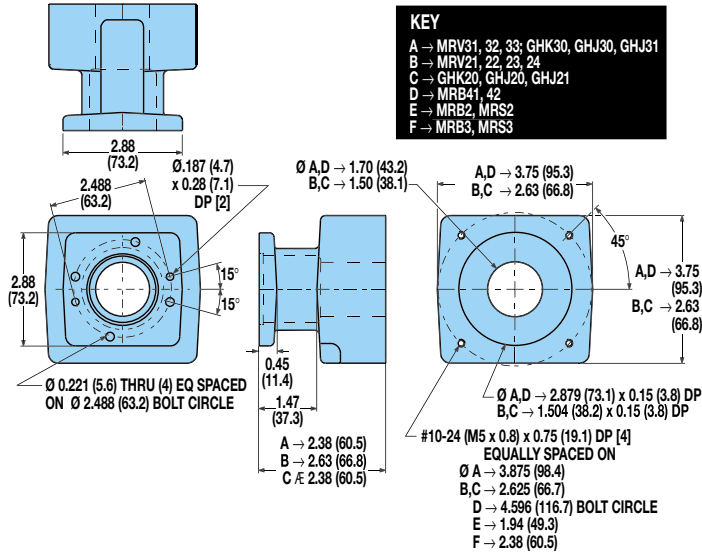

For gearhead dimensions and specifications, refer to page F-10.

BCS/MCS15: REVERSE PARALLEL MOUNTING

SPECIFICATIONS

| MOTOR | WEIGHT OF REDUCTION DRIVE | | | | REDUCTION INERTIA AT MOTOR SHAFT | | | |
|------------------------------------|---------------------------|--------|------|--------|----------------------------------|--------------------|--------------------|--------------------|
| | 1:1 | | 2:1 | | 1:1 | | 2:1 | |
| | lbs | kg | lbs | kg | lb-in ² | kg-cm ² | lb-in ² | kg-cm ² |
| BRUSHLESS MRV21, 22, 23, 24 | 2.17 | 0.9843 | 2.40 | 1.0886 | .070 | .2043 | .095 | .2767 |
| MRV31, 32, 33 | 2.61 | 1.1839 | 2.84 | 1.2882 | .070 | .2043 | .095 | .2767 |

REDUCTION EFFICIENCY: 0.95

BOTTOM MOUNT

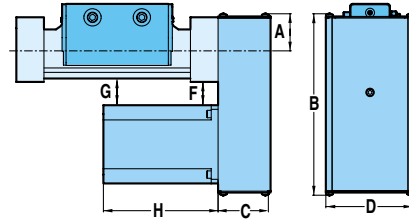

SIDE MOUNT (Right Shown)

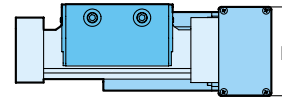
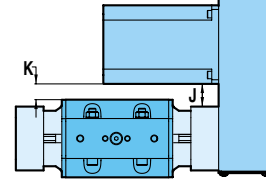

TOP MOUNT

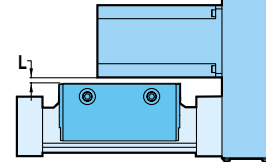

DIMENSIONS

| MOTOR | A | | B | | C | | D | | F | | G | | H | | J | | K | | L | |
|------------------------|------|------|------|-------|------|------|------|-------|------|------|------|------|------|-------|------|------|------|------|------|------|
| | in. | mm | in. | mm | in. | mm | in. | mm | in. | mm | in. | mm | in. | mm | in. | mm | in. | mm | in. | mm |
| BRUSHLESS MRV21 | 1.44 | 36.6 | 7.46 | 189.4 | 2.13 | 54.0 | 3.25 | 82.6 | 1.70 | 43.2 | 1.85 | 47.0 | 4.75 | 120.7 | 1.67 | 42.4 | 1.86 | 47.2 | 0.98 | 25.3 |
| MRV22 | 1.44 | 36.6 | 7.46 | 189.4 | 2.13 | 54.0 | 3.25 | 82.6 | 1.70 | 43.2 | 1.85 | 47.0 | 5.75 | 146.1 | 1.67 | 42.4 | 1.86 | 47.2 | 0.98 | 25.3 |
| MRV23 | 1.44 | 36.6 | 7.46 | 189.4 | 2.13 | 54.0 | 3.25 | 82.6 | 1.70 | 43.2 | 1.85 | 47.0 | 6.75 | 171.5 | 1.67 | 42.4 | 1.86 | 47.2 | 0.98 | 25.3 |
| MRV24 | 1.44 | 36.6 | 7.46 | 189.4 | 2.13 | 54.0 | 3.25 | 82.6 | 1.70 | 43.2 | 1.85 | 47.0 | 7.75 | 196.9 | 1.67 | 42.4 | 1.86 | 47.2 | 0.98 | 25.3 |
| MRV31 | 2.12 | 53.8 | 8.14 | 206.6 | 2.38 | 60.3 | 4.00 | 101.6 | 1.05 | 26.7 | 1.21 | 30.7 | 6.11 | 155.2 | 1.02 | 25.9 | 1.21 | 30.7 | 0.33 | 8.9 |
| MRV32 | 2.12 | 53.8 | 8.14 | 206.6 | 2.38 | 60.3 | 4.00 | 101.6 | 1.05 | 26.7 | 1.21 | 30.7 | 7.36 | 186.9 | 1.02 | 25.9 | 1.21 | 30.7 | 0.33 | 8.9 |
| MRV33 | 2.12 | 53.8 | 8.14 | 206.6 | 2.38 | 60.3 | 4.00 | 101.6 | 1.05 | 26.7 | 1.21 | 30.7 | 8.61 | 218.7 | 1.02 | 25.9 | 1.21 | 30.7 | 0.33 | 8.9 |

Axi-dyne® BCS/MCS20 Series

ACME SCREW SPECIFICATIONS



BCS/MCS20 ACME SCREW SPECIFICATIONS

CRITICAL SPEED WITH 3/4" ENGLISH ACME SCREW

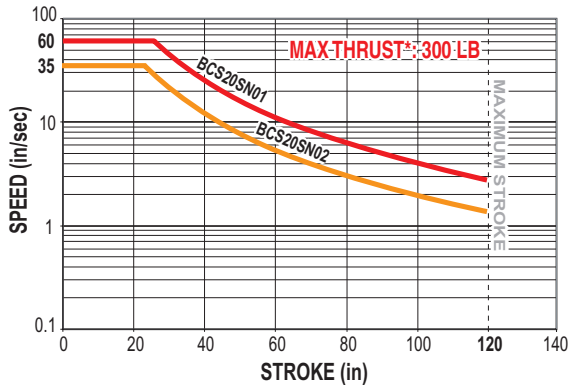

CRITICAL SPEED WITH 19mm METRIC ACME SCREW

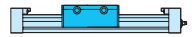
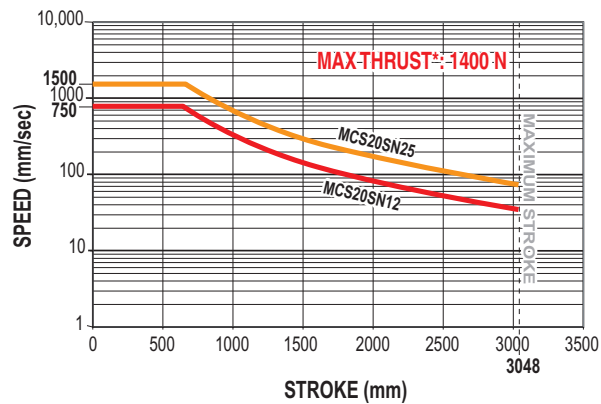

RODLESS

BCS/MCS20 Series

- Acme screw critical speed capacities and PV limits

PV LIMITS: 3/4" 1TPI ENGLISH ACME SCREW

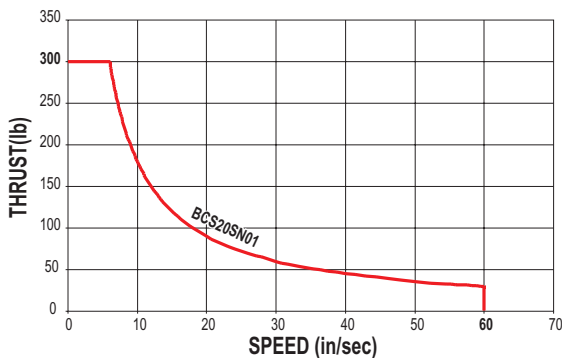

PV LIMITS: 19mm METRIC ACME SCREW w/25mm LEAD

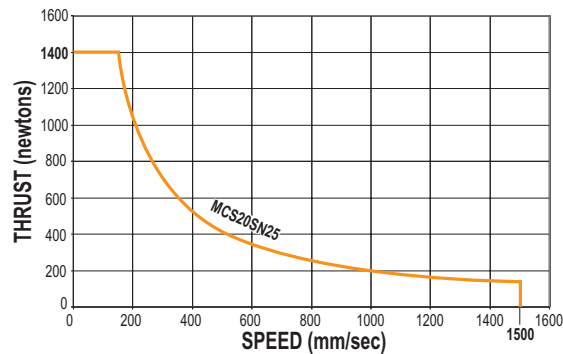

PV LIMITS: 3/4" 2TPI ENGLISH ACME SCREW

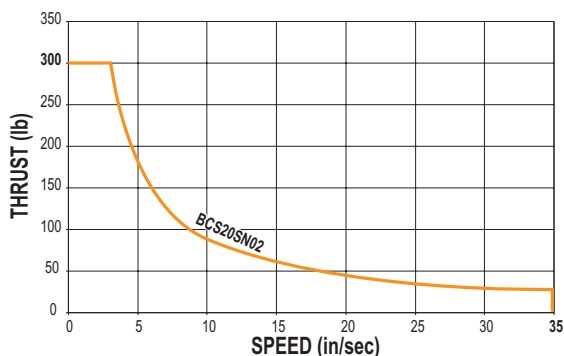

PV LIMITS: 19mm METRIC ACME SCREW w/12mm LEAD

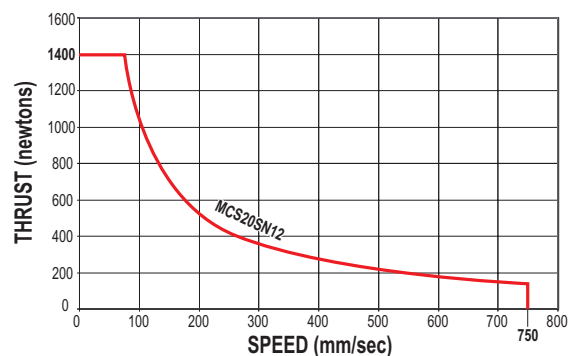

SN = Solid Nut
SNA = Solid Anti-backlash Nut



* Maximum thrust is the maximum continuous dynamic thrust subject to Thrust x Velocity limitation.

PV LIMITS: Any material which carries a sliding load is limited by heat buildup. The factors that affect heat generation rate in an application are the pressure on the nut in pounds per square inch and the surface velocity in feet per minute. The product of these factors provides a measure of the severity of an application.

$$P = \frac{\text{Thrust}}{\text{Max. Thrust Rating}} \times V = \frac{\text{Speed}}{\text{Max. Speed Rating}} \leq 0.1$$

Axi-dyne[®] BCS/MCS20 Series

BALL SCREW SPECIFICATIONS

BCS20/MCS20 BALL SCREW SPECIFICATIONS

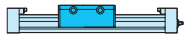

RODLESS

BCS/MCS20 Series

- Ball screw critical speed capacities and life calculations

CRITICAL SPEED WITH 3/4" ENGLISH BALL SCREW, 2TPI

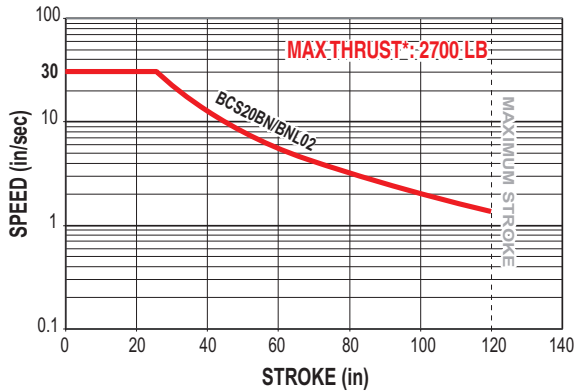

LIFE CALCULATION: 3/4" ENGLISH BALL SCREW, 5TPI

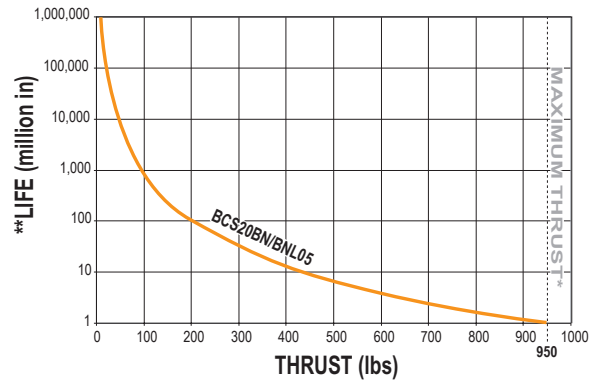

LIFE CALCULATION: 3/4" ENGLISH BALL SCREW, 2TPI

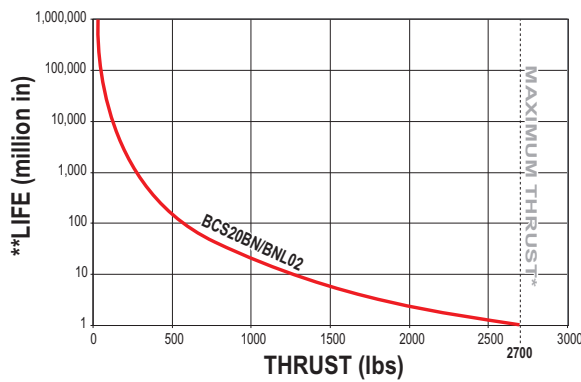

CRITICAL SPEED WITH 20mm METRIC BALL SCREW

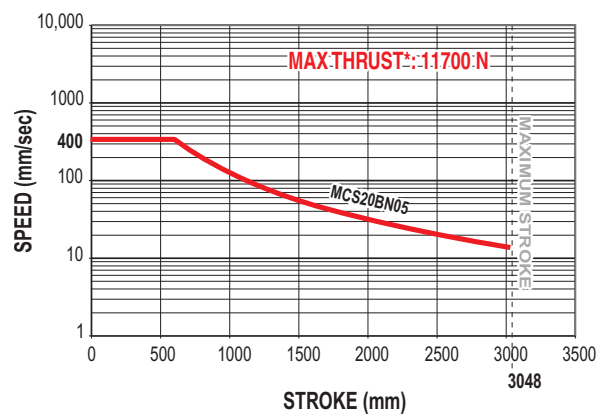

CRITICAL SPEED WITH 3/4" ENGLISH BALL SCREW, 5TPI

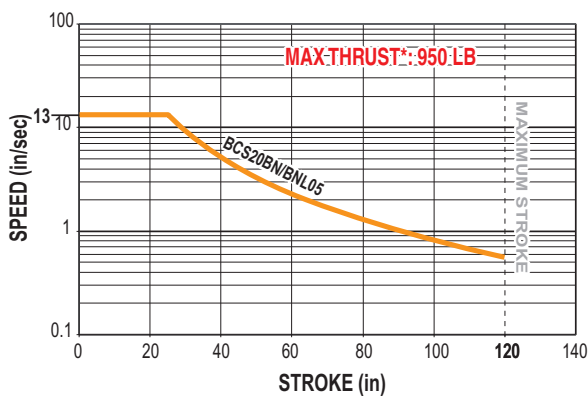

LIFE CALCULATION: 20mm METRIC BALL SCREW w/5mm LEAD

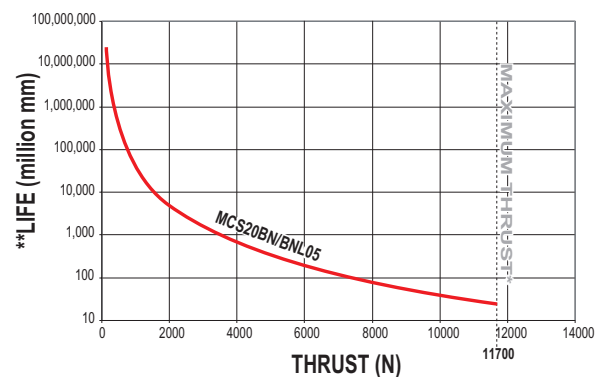

BN = Ball Nut

BNL = Ball Nut with Low-Backlash



** Maximum thrust reflects 90% reliability for 1 million linear inches of travel.*

***Life indicates theoretical maximum life of screw only, under ideal conditions and does not indicate expected life of actuator.*

Axi-dyne® BCS/MCS20 Series

DIMENSIONS

BCS20 ACTUATOR AND OPTIONS

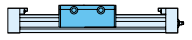
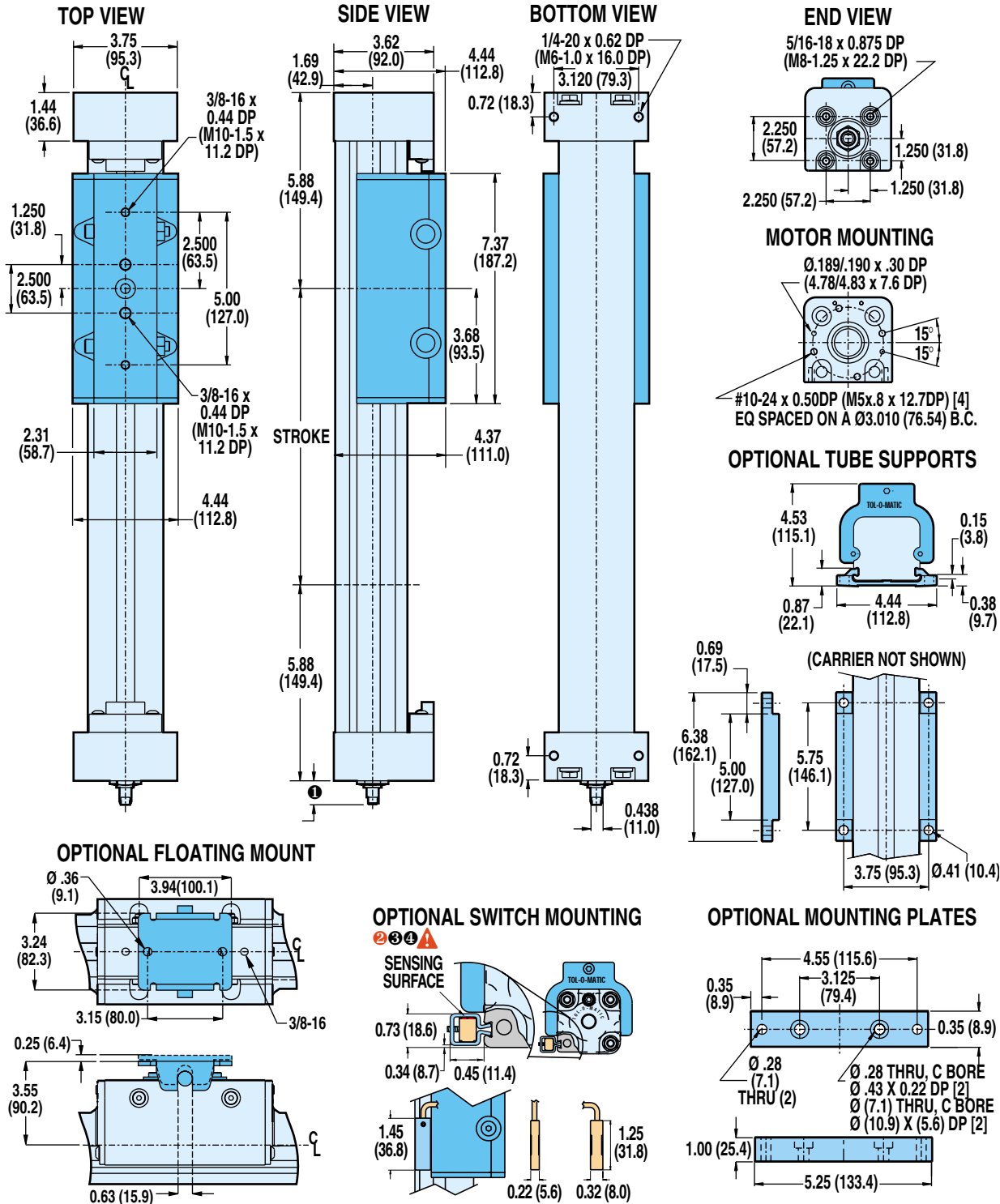

RODLESS

BCS/MCS20 Series

- Actuator and option dimensions

① SHAFT LENGTH

| | |
|---|-------------|
| In-line mounting | 0.78 (19.8) |
| Extended shaft for RP & 23-frame motor | 2.16 (54.9) |
| Extended shaft for RP & 34-frame motor | 2.16 (54.9) |
| Extended shaft for RP & 40-frame motor | 2.31 (58.7) |
| Extended shaft for purchases prior to 6/24/02 | 2.28 (57.9) |

⚠ CAUTION: DO NOT OVERTIGHTEN SWITCH HARDWARE WHEN INSTALLING

② NOTE: The scored face of the switch indicates the sensing surface and must face toward the magnet

③ NOTE: Some actuators require switch mounting on a specific side of the actuator. Call Tol-O-Matic 1-800-328-2174 for details

Unless otherwise noted, all dimensions shown are in inches (Dimensions in parenthesis are in millimeters)

Axi-dyne[®] BCS/MCS20 Series

DIMENSIONS

BCS/MCS20: IN-LINE MOUNT FOR MOTORS AND GEARHEADS

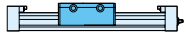

RODLESS

BCS/MCS20 Series

- In-line motor mounting

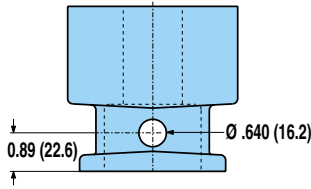

MOTORS KEY

- A → MRV3x, MRB3x
- B → MRV2x
- C → GHK20x, GHJ20x, GHJ21x, GHJ30x, GHJ31x, GHK30
- D → MRB4x
- E → MRB2, MRS2
- F → MRB3, MRS3

! For gearhead dimensions and specifications, refer to page F-10.

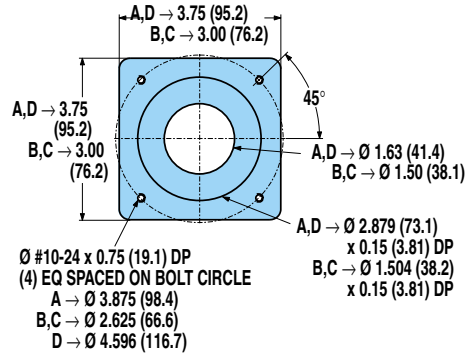
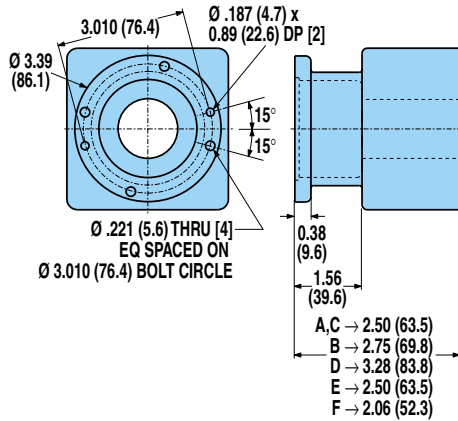

Axi-dyne® BCS/MCS20 Series

DIMENSIONS

BCS/MCS20: REVERSE PARALLEL MOUNTING

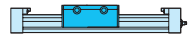
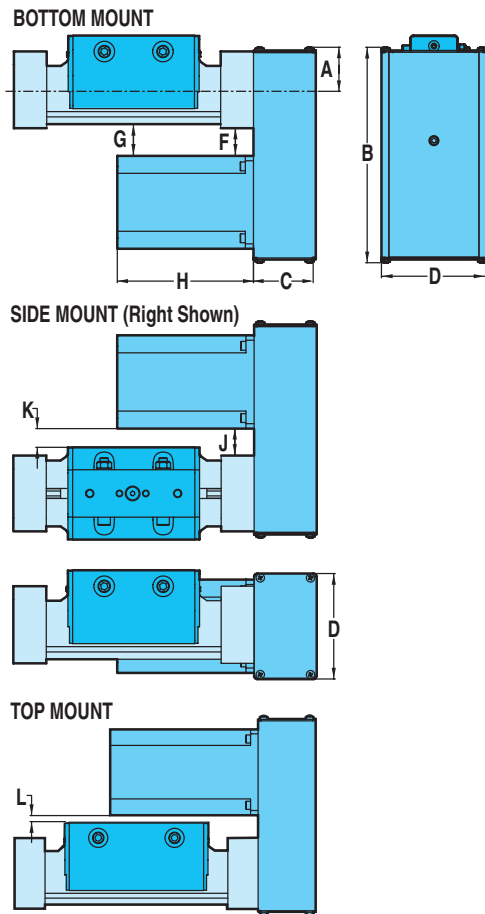

RODLESS

BCS/MCS20 Series

- Reverse parallel mounting

SPECIFICATIONS

| MOTOR | WEIGHT OF REDUCTION DRIVE | | | | REDUCTION INERTIA AT MOTOR SHAFT | | | |
|------------------------------------|---------------------------|------|------|------|----------------------------------|--------------------|--------------------|--------------------|
| | 1:1 | | 2:1 | | 1:1 | | 2:1 | |
| | lbs | kg | lbs | kg | lb-in ² | kg-cm ² | lb-in ² | kg-cm ² |
| BRUSHLESS MRV21, 22, 23, 24 | 3.11 | 1.41 | 3.27 | 1.48 | .118 | .3447 | .100 | .2928 |
| MRV31, 32, 33 | 3.18 | 1.44 | 3.34 | 1.51 | .118 | .3447 | .100 | .2928 |

REDUCTION EFFICIENCY: 0.95

DIMENSIONS

| MOTOR | A | | B | | C | | D | | F | | G | | H | | J | | K | | L | |
|------------------------|------|------|------|-------|------|------|------|-------|------|------|------|------|------|-------|------|------|------|------|------|------|
| | in. | mm | in. | mm | in. | mm | in. | mm | in. | mm | in. | mm | in. | mm | in. | mm | in. | mm | in. | mm |
| BRUSHLESS MRV21 | 1.44 | 36.6 | 9.31 | 236.5 | 2.38 | 60.3 | 4.00 | 101.6 | 2.44 | 61.8 | 2.50 | 63.5 | 4.75 | 120.7 | 2.25 | 57.2 | 2.56 | 65.0 | 1.38 | 34.9 |
| MRV22 | 1.44 | 36.6 | 9.31 | 236.5 | 2.38 | 60.3 | 4.00 | 101.6 | 2.44 | 61.8 | 2.50 | 63.5 | 5.75 | 146.1 | 2.25 | 57.2 | 2.56 | 65.0 | 1.38 | 34.9 |
| MRV23 | 1.44 | 36.6 | 9.31 | 236.5 | 2.38 | 60.3 | 4.00 | 101.6 | 2.44 | 61.8 | 2.50 | 63.5 | 6.75 | 171.5 | 2.25 | 57.2 | 2.56 | 65.0 | 1.38 | 34.9 |
| MRV24 | 1.44 | 36.6 | 9.31 | 236.5 | 2.38 | 60.3 | 4.00 | 101.6 | 2.44 | 61.8 | 2.50 | 63.5 | 7.75 | 196.9 | 2.25 | 57.2 | 2.56 | 65.0 | 1.38 | 34.9 |
| MRV31 | 1.96 | 49.7 | 9.83 | 249.6 | 2.38 | 60.3 | 4.00 | 101.6 | 1.79 | 45.5 | 1.86 | 47.2 | 6.11 | 155.2 | 1.61 | 40.9 | 1.92 | 48.8 | 0.73 | 18.5 |
| MRV32 | 1.96 | 49.7 | 9.83 | 249.6 | 2.38 | 60.3 | 4.00 | 101.6 | 1.79 | 45.5 | 1.86 | 47.2 | 7.36 | 186.9 | 1.61 | 40.9 | 1.92 | 48.8 | 0.73 | 18.5 |
| MRV33 | 1.96 | 49.7 | 9.83 | 249.6 | 2.38 | 60.3 | 4.00 | 101.6 | 1.79 | 45.5 | 1.86 | 47.2 | 8.61 | 218.7 | 1.61 | 40.9 | 1.92 | 48.8 | 0.73 | 18.5 |

Axi-dyne® BCS/MCS Screw Drives

ORDERING

BASE MODEL SPECIFICATIONS

OPTIONS SPECIFICATIONS

BCS 20 BN02 SK45 RPL1 DC18 KT2 MP4

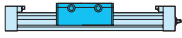

RODLESS

BCS/MCS Series

- Ordering

MODEL TYPE

BCS BCS Series English Screw Drive
MCS MCS Series Metric Screw Drive

TUBE BORE DIAMETER

10 1-inch (25 mm) bore
 15 1-1/2-inch (40 mm) bore
 20 2-inch (50 mm) bore

NUT/SCREW CONFIGURATION

ENGLISH MODELS

| SOLID NUT / PITCH (turn/in) | SERIES |
|-----------------------------|---------------|
| SN01 | BCS10, 15, 20 |
| SN02 | BCS10, 15, 20 |
| SNA02 | BCS10, 15 |
| SN05 | BCS10, 15 |

| BALL NUT / PITCH (turn/in) | SERIES |
|----------------------------|-----------|
| BN02 | BCS15, 20 |
| BNL02 | BCS15, 20 |
| BN05 | BCS15, 20 |
| BNL05 | BCS15, 20 |
| BN08 | BCS10 |
| BNL08 | BCS10 |

METRIC MODELS

| SOLID NUT / LEAD (mm/turn) | SERIES |
|----------------------------|---------------|
| SN12 | MCS10, 15, 20 |
| SN25 | MCS10, 15, 20 |

| BALL NUT / LEAD (mm/turn) | SERIES |
|---------------------------|-----------|
| BN02 | MCS10 |
| BNL02 | MCS10 |
| BN05 | MCS15, 20 |
| BNL05 | MCS15, 20 |

STROKE LENGTH

SK Stroke, then enter desired stroke length in decimal inches

MOTOR MOUNTING / REDUCTIONS

(must choose one)

LMI In-Line mounting
LME23 Ext. shaft for RP & 23 frame motor
LME34 Ext. shaft for RP & 34 frame motor
LME40 Ext. shaft for RP & 40 frame motor
****LMX** Extended shaft - old style (see note)
****For replacement actuators with extended motor shafts purchased prior to 6/24/02 use LMX**

⚠ A motor size and code must be selected when specifying a reverse-parallel mounting configuration. Reference the ordering pages in sections F, G and H for the motor types and selections.

RPL1 1:1 Reverse-Parallel mount left
RPR1 1:1 Reverse-Parallel mount right
RPB1 1:1 Reverse-Parallel mount bottom
RPT1 1:1 Reverse-Parallel mount top
RPL2 2:1 Reverse-Parallel mount left
RPR2 2:1 Reverse-Parallel mount right
RPB2 2:1 Reverse-Parallel mount bottom
RPT2 2:1 Reverse-Parallel mount top

AUXILIARY CARRIER

DC_ Auxiliary Carrier, then center-to-center spacing desired in decimal inches. (Center-to-Center spacing will add to overall dead length and will not subtract from the stroke length)

SWITCHES

RM_ Reed Switch (Form A) with 5-meter lead/QD, and quantity desired
RT_ Reed Switch (Form A) with 5-meter lead, and quantity desired
BM_ Reed Switch (Form C) with 5-meter lead/QD, and quantity desired
BT_ Reed Switch (Form C) with 5-meter lead, and quantity desired
KM_ Hall-effect Sinking Switch with 5-meter lead/QD, and quantity desired
KT_ Hall-effect Sinking Switch with 5-meter lead, and quantity desired
TM_ Hall-effect Sourcing Switch with 5-meter lead/QD, and quantity desired
TT_ Hall-effect Sourcing Switch with 5-meter lead, and quantity desired
CM_ TRIAC Switch with 5-meter lead/QD, and quantity desired
CT_ TRIAC Switch with 5-meter lead, and quantity desired

TO ORDER MOTORS/CONTROLS/INTERFACES

BRUSHLESS SERVO (SEE PAGE F-33)

SUPPORTS AND MOUNTING PLATES

(both may be selected)
TS_ Tube Supports plus quantity desired
MP_ Mounting Plates plus quantity desired

⚠ Not all codes listed are compatible with all options.

Use the Tol-O-Motion™ Sizing Software to determine available options and accessories based on your application requirements.

FIELD RETROFIT KITS

| ITEM | B3S10 | B3S15 | B3S20 | M3S10 | M3S15 | M3S20 |
|-----------------|-----------|-----------|-----------|-----------|-----------|-----------|
| Tube Supports | 4510-1010 | 4515-1010 | 4520-1010 | 4510-1010 | 4515-1010 | 4520-1010 |
| Mounting Plates | 0910-9133 | 0915-9135 | 0920-9038 | 0510-9105 | 0515-9138 | 0520-9105 |