

M8 picofast® Cordset Part Number Key

Part Number Keys are to assist in IDENTIFICATION ONLY. Consult factory for catalog items not identified.

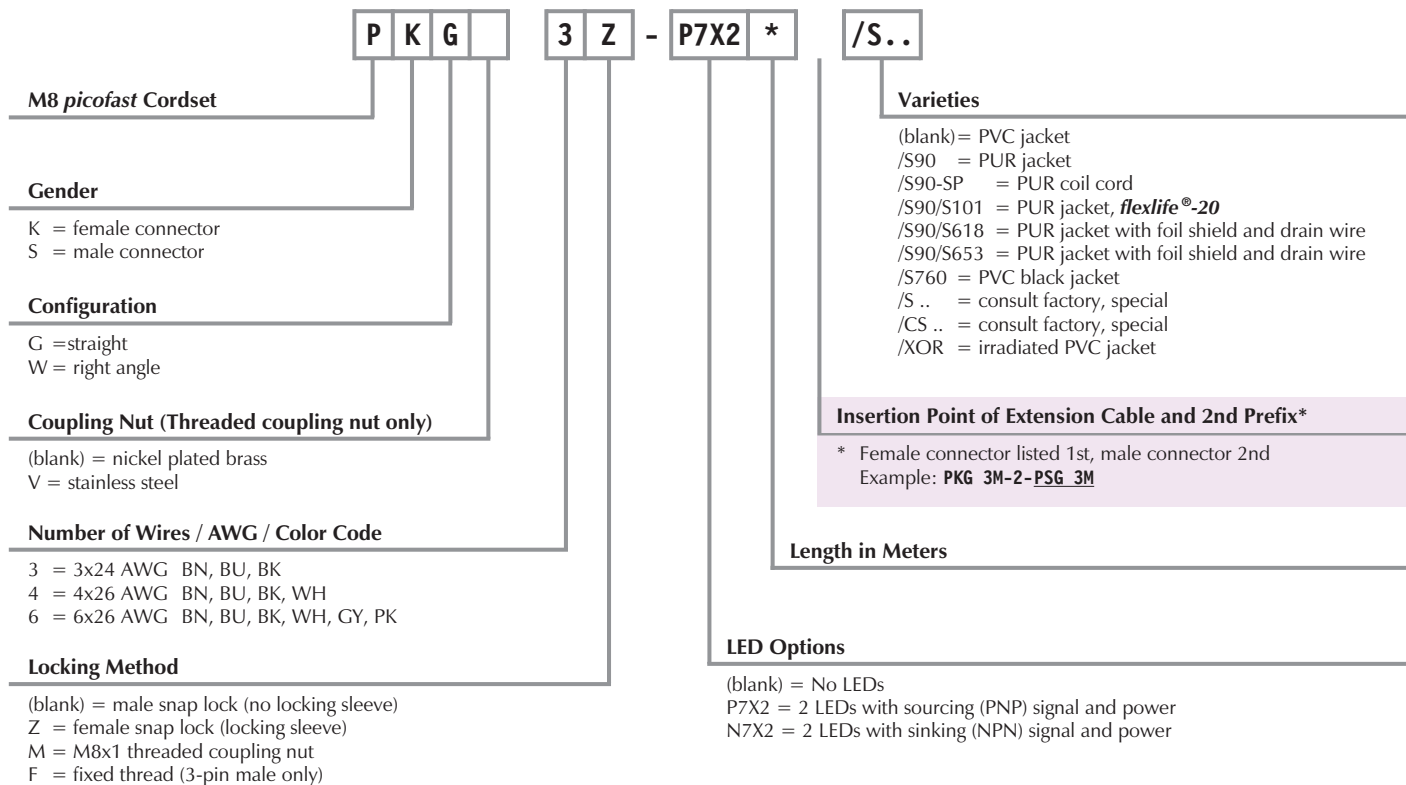

Extension Examples:

Hybrid connector extensions also available. Consult factory.

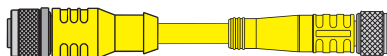

R K C 4.4 T - 2 - P K G 4 M

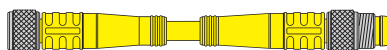

P K G 3 M - 2 - P S G 3 M

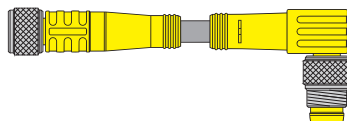

P K G 3 M - 2 - P S W 3 M

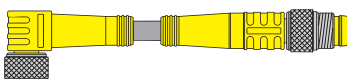

P K W 3 M - 2 - P S G 3 M