

SPECIFICATIONS	
MATERIAL	
HOUSING MATERIAL	ALUMINUM ALLOY
HOUSING FINISH/COLOR	EPOXY/BLACK
CONTACT CARRIERS	TPU
CONTACTS	GOLD PLATED, SPRING BUSHING
DISCONNECTS	NICKEL PLATED BRASS
ELECTRICAL DATA	
OPERATING VOLTAGE	250 VAC, 300 VDC
OPERATING CURRENT	4.0 AMPS/PORT, 4 AMP TOTAL
MECHANICAL DATA	
PROTECTION CLASS to DIN 40050	IP 67 ONLY WHEN RKM 66 CORDSET AND ALL RECEPTACLES ARE COVERED WITH PLUGS OR CONNECTED
OPERATING TEMPERATURE	-40°C to +105°C (-40°F to +221°F)

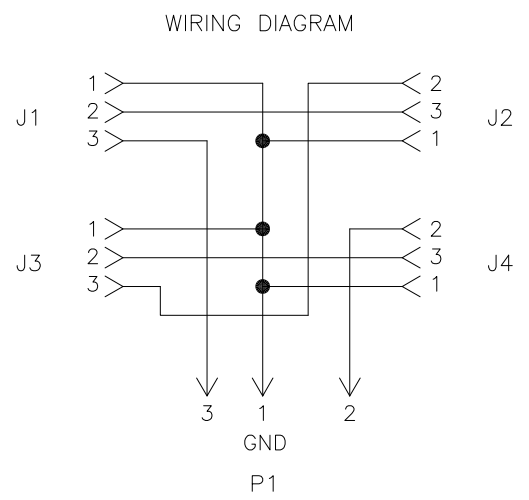
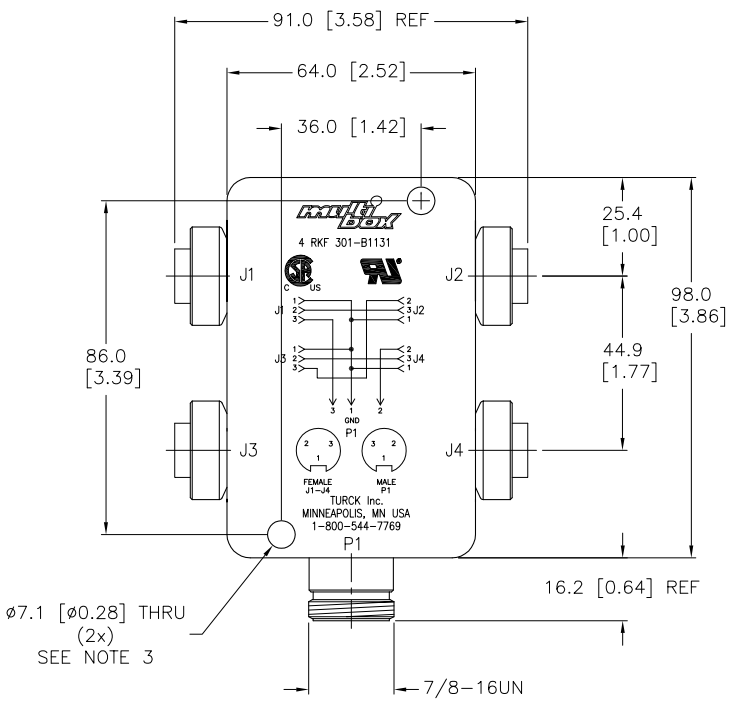

SOURCE DRAWING - FOR REFERENCE ONLY

- NOTES:
1. BOX HEIGHT IS 1.36 [36.0 mm] NOMINAL.
  2. CLEARANCE HOLE FOR 1/4-20 MOUNTING SCREWS (NOT SUPPLIED).
  3. MATING CORDSET FOR B1131 CONNECTOR - RKM 36-\* M.

RELATED DOCUMENTS 1. 2. 3. 4.	3RD ANGLE PROJECTION 	THIS DRAWING IS PROPERTY OF TURCK INC. USE OF THIS DOCUMENT WITHOUT WRITTEN PERMISSION IS PROHIBITED.		<b>TURCK INC</b> High Technology Sensors and Automation Controls 3000 CAMPUS DRIVE MINNEAPOLIS, MN 55441 1-800-544-7769 (763) 553-7300 (763) 553-0708 fax turck.com	
	MATERIAL	DRFT IK	DATE 6/25/96	DESCRIPTION 4 RKF 301-B1131	
FINISH	ALL DIMENSIONS DISPLAYED ON THIS DRAWING ARE FOR REFERENCE ONLY	DSGN	SCALE 1=2.0	IDENTIFICATION NO. U2361-90	
	CONTACT TURCK FOR MORE INFORMATION	UNIT OF MEASUREMENT <b>MILLIMETER [ INCH ]</b>		REV D	
D	DRAWING PROCESSED AS PART OF ECO 33971	CBM	04/07/11	33971	
REV	DESCRIPTION	BY	DATE	ECO NO.	DO NOT SCALE THIS DRAWING
					FILE: U2361-90
					SHEET 1 OF 1