

FEMALE END VIEW

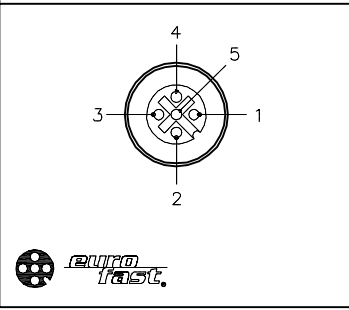

SPECIFICATIONS

NUMBER OF CONDUCTORS [AWG]	3x18 AWG, 8x22 AWG
DRAIN/SHIELD	22 AWG/ALUMINUM-POLYESTER FOIL
CONDUCTOR INSULATION MATERIAL	PVC
OUTER JACKET MATERIAL/COLOR	PVC/YELLOW
HOUSING MATERIAL/COLOR	NYLON/BLACK
RECEPTACLE MATERIAL/PLATING	BRASS/NICKEL
CONTACT CARRIER MATERIAL	NYLON
CONTACT MATERIAL/PLATING	BRASS/GOLD
O-RING MATERIAL	VITON
OPERATING VOLTAGE [V]	10-30 VDC
OPERATING CURRENT [A]	2.0 AMPS/SIGNAL, 9.0 AMPS TOTAL
PROTECTION CLASS	IP68, IP69K: ONLY WHEN ALL RECEPTACLES ARE COVERED WITH PLUGS OR CONNECTED
OPERATING TEMPERATURE	-40°C to +85°C (-40°F to +185°F)

WIRING DIAGRAM

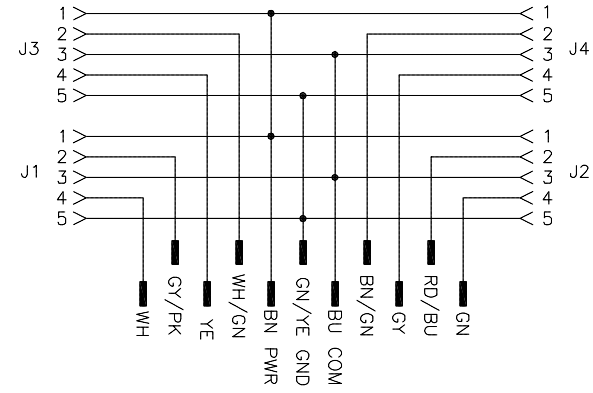

CABLE LENGTH	TOLERANCE*
ALL LENGTHS	+ 4% (OR 50mm) OF LENGTH - 0% (OR 0mm) OF LENGTH WHICHEVER IS GREATER
STRIP LENGTH	TOLERANCE*
0-7mm	±0.5mm
8-29mm	±1.0mm
30-49mm	±2.0mm
50-69mm	±3.0mm
70-100mm	±4.0mm
OVER 100mm	±5.0mm

* UNLESS OTHERWISE SPECIFIED

* METERS
SEE NOTE 1

NOTES:
1. "*" INDICATES CABLE LENGTHS IN METERS. CONTACT TURCK TO ORDER SPECIFIC LENGTH.

SOURCE DRAWING - FOR REFERENCE ONLY

RELATED DOCUMENTS 1. 2. 3. 4.	3RD ANGLE PROJECTION 	THIS DRAWING IS CONFIDENTIAL AND THE PROPERTY OF TURCK INC. USE OF THIS DOCUMENT WITHOUT WRITTEN PERMISSION IS PROHIBITED.		TURCK IAC High Technology Sensors and Automation Controls 3000 CAMPUS DRIVE MINNEAPOLIS, MN 55441 1-800-544-7769 (763) 553-7300 (763) 553-0708 fax turck.com			
		DRFT	RWC	DATE	10/08/04	DESCRIPTION	4MB12Z-5-*
MATERIAL	SEE SPECIFICATIONS	APVD		SCALE	1=2.0	IDENTIFICATION NO.	
FINISH	SEE SPECIFICATIONS	UNIT OF MEASUREMENT		MILLIMETER [INCH]		REV	H
		CONTACT TURCK FOR MORE INFORMATION		DO NOT SCALE THIS DRAWING		FILE: 777003736	SHEET 1 OF 1

H	UPDATE PROTECTION CLASS PER ECO	KMY	05/27/14	45751
REV	DESCRIPTION	BY	DATE	ECO NO.