

FEMALE END VIEW

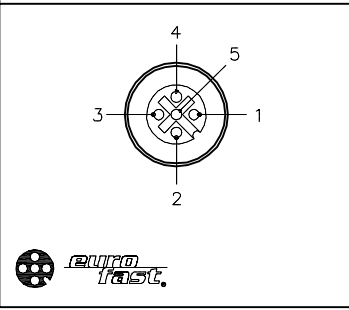

SPECIFICATIONS

| | |
|-------------------------------|--|
| NUMBER OF CONDUCTORS [AWG] | 3x18 AWG, 8x22 AWG |
| CONDUCTOR INSULATION MATERIAL | POLYESTER ELASTOMER |
| OUTER JACKET MATERIAL/COLOR | TPE/YELLOW |
| HOUSING MATERIAL/COLOR | NYLON/BLACK |
| RECEPTACLE MATERIAL/PLATING | BRASS/NICKEL |
| CONTACT CARRIER MATERIAL | NYLON |
| CONTACT MATERIAL/PLATING | BRASS/GOLD |
| O-RING MATERIAL | VITON |
| OPERATING VOLTAGE [V] | 10-30 VDC |
| OPERATING CURRENT [A] | 2.0 AMPS/SIGNAL, 9.0 AMPS TOTAL |
| PROTECTION CLASS | IP68, IP69K: ONLY WHEN ALL RECEPTACLES ARE COVERED WITH PLUGS OR CONNECTED |
| OPERATING TEMPERATURE | -40°C to +85°C (-40°F to +185°F) |

WIRING DIAGRAM

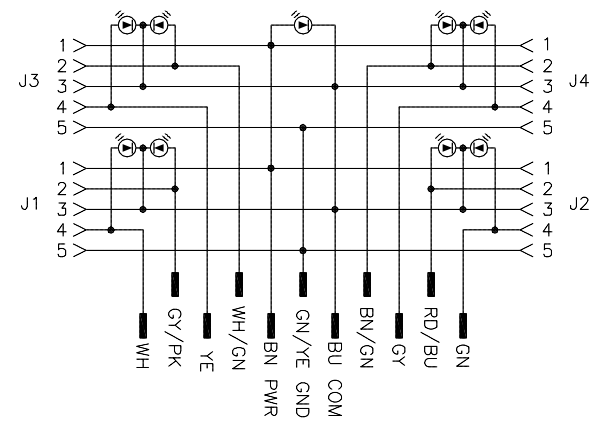

| CABLE LENGTH | TOLERANCE* |
|--------------|---|
| ALL LENGTHS | + 4% (OR 50mm) OF LENGTH - 0% (OR 0mm) OF LENGTH WHICHEVER IS GREATER |
| STRIP LENGTH | TOLERANCE* |
| 0-7mm | ±0.5mm |
| 8-29mm | ±1.0mm |
| 30-49mm | ±2.0mm |
| 50-69mm | ±3.0mm |
| 70-100mm | ±4.0mm |
| OVER 100mm | ±5.0mm |

* UNLESS OTHERWISE SPECIFIED

- NOTES:
- "*" INDICATES CABLE LENGTHS IN METERS. CONTACT TURCK TO ORDER SPECIFIC LENGTH.
 - "/S101" DESIGNATES, FLEXLIFE-20 CABLE.

SOURCE DRAWING - FOR REFERENCE ONLY

| | | | | | |
|---|---|--|---|---|--------------------|
| RELATED DOCUMENTS 1. 2. 3. 4. | 3RD ANGLE PROJECTION | THIS DRAWING IS CONFIDENTIAL AND THE PROPERTY OF TURCK INC. USE OF THIS DOCUMENT WITHOUT WRITTEN PERMISSION IS PROHIBITED. | | 3000 CAMPUS DRIVE MINNEAPOLIS, MN 55441 1-800-544-7769 (763) 553-7300 (763) 553-0708 fax turck.com | |
| | | DRFT | RWC | DATE | 10/08/04 |
| MATERIAL SEE SPECIFICATIONS | ALL DIMENSIONS DISPLAYED ON THIS DRAWING ARE FOR REFERENCE ONLY | APVD | | SCALE | 1=2.0 |
| FINISH SEE SPECIFICATIONS | | CONTACT TURCK FOR MORE INFORMATION | UNIT OF MEASUREMENT MILLIMETER [INCH] | | IDENTIFICATION NO. |
| DO NOT SCALE THIS DRAWING | | | FILE: 777003267 | | SHEET 1 OF 1 |

| | | | | |
|-----|---------------------------------|-----|----------|---------|
| I | UPDATE PROTECTION CLASS PER ECO | KMY | 05/27/14 | 45751 |
| REV | DESCRIPTION | BY | DATE | ECO NO. |