

SPECIFICATIONS	
CABLE JACKET/COLOR	PVC/BLACK
NUMBER OF CONDUCTORS [AWG]	6x18 AWG
HOUSING MATERIAL	ALUMINUM ALLOY
HOUSING FINISH/COLOR	EPOXY/BLACK
CONTACT CARRIERS	TPU
CONTACTS	BRASS/GOLD
OPERATING VOLTAGE	250 VAC / 300 VDC
OPERATING CURRENT	4 A PER PORT, 9.0 A TOTAL
PROTECTION CLASS to DIN 40050	IP 67 - ONLY WHEN ALL RECEPTACLES ARE COVERED WITH PLUGS OR CONNECTED
OPERATING TEMPERATURE	-40°C to 90°C (-40°F to 194°F)

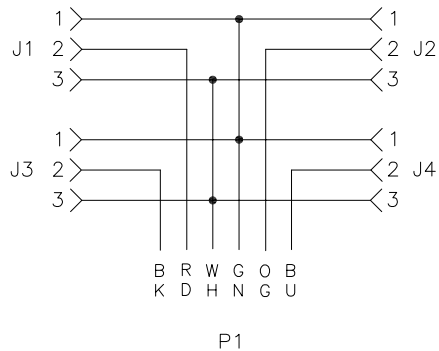

CONNECTORS J1-J4

1 = GROUND
2 = LOAD (L2)
3 = COMMON (L1)

FUNCTION	OUTPUT WIRE COLOR
COMMON (L1)	WHITE
GROUND	GREEN
J1(L2)	RED
J2(L2)	ORANGE
J3(L2)	BLACK
J4(L2)	BLUE

CABLE LENGTH	TOLERANCE
ALL LENGTHS	+ 4% (OR 50mm) OF LENGTH - 0% (OR 0mm) OF LENGTH WHICHEVER IS GREATER
STRIP LENGTH	TOLERANCE
0-7mm	±0.5mm
8-29mm	±1.0mm
30-49mm	±2.0mm
50-69mm	±3.0mm
70-100mm	±4.0mm
OVER 100mm	±5.0mm

- NOTES:
- "*" DESIGNATES CABLE LENGTH IN METERS. CONTACT TURCK TO ORDER SPECIFIC LENGTHS.
 - BOX HEIGHT IS 1.36 [34.5] NOMINAL.
 - CLEARANCE HOLE FOR 1/4-20 MOUNTING SCREWS (NOT INCLUDED).

SOURCE DRAWING - FOR REFERENCE ONLY

RELATED DOCUMENTS	3RD ANGLE PROJECTION	THIS DRAWING IS CONFIDENTIAL AND THE PROPERTY OF TURCK INC. USE OF THIS DOCUMENT WITHOUT WRITTEN PERMISSION IS PROHIBITED.		 High Technology Sensors and Automation Controls		3000 CAMPUS DRIVE MINNEAPOLIS, MN 55441 1-800-544-7769 (763) 553-7300 (763) 553-0708 fax turck.com	
1.		DRFT	RJP	DATE	6/21/95	DESCRIPTION 4 RKF 30-*M	
2.		APVD		SCALE	1=1.5		
3.	ALL DIMENSIONS DISPLAYED ON THIS DRAWING ARE FOR REFERENCE ONLY	UNIT OF MEASUREMENT		IDENTIFICATION NO.		REV G	
4.		MILLIMETER [INCH]					
MATERIAL	SEE SPECIFICATIONS	CONTACT TURCK FOR MORE INFORMATION		DO NOT SCALE THIS DRAWING		FILE: 777001294	
FINISH		SEE SPECIFICATIONS		SHEET 1 OF 1			

G	UPDATE CABLE DIAMETER	KMY	04/16/12	37382
REV	DESCRIPTION	BY	DATE	ECO NO.