

# **BALDOR**® • **RELIANCE**

## **Product Information Packet**

# **812RE**

**.75HP,3600RPM,1PH,60HZ,3524C,GRND**

Copyright © All product information within this document is subject to Baldor Electric Company copyright © protection, unless otherwise noted.

Part Detail							
Revision:	AP	Status:	PRD/A	Change #:		Proprietary:	No
Type:	AC	Prod. Type:	3524C	Elec. Spec:	G8WG0011	CD Diagram:	
Enclosure:	TENV	Mfg Plant:		Mech. Spec:	G8-212	Layout:	
Frame:		Mounting:	F1	Poles:	02	Created Date:	08-08-2007
Base:	RG	Rotation:	FOS	Insulation:	B	Eff. Date:	08-07-2012
Leads:	4#18	Literature:		Elec. Diagram:		Replaced By:	
Nameplate NP0235							
CAT.NO.	812RE						
HP	.75	VOLTS			115/230		
PHASE	1	AMPS			4.8/2.4		
HZ	60	RPM			3600		
SER.NO							
SPEC.	G8-212-11						

Parts List		
Part Number	Description	Quantity
SA037660	SA G8-212-11	1.000 EA
RA033685	RA G8-212-11	1.000 EA
OC3016F12SP	CYL OIL CAP 16MFD/370V	1.000 EA
G8BA3000	G8 & G10 BASE	1.000 EA
19XX2510A14	1/4-10 X 7/8 HEX HD PLASTITE SCREW	4.000 EA
HW1000A25	1/4 SAE FLAT WASHER (FS)	4.000 EA
HW1003A50	LOCKWASHER,1/2",EXT.TOOTHZINC PLATED	1.000 EA
HA6053A01ZP	CLAMP, CAPACITOR 2" DIA, WHITE ZINC PLAT	1.000 EA
51XN1032A04	10-32 X 0.25 HX WS SL SR	3.000 EA
XY1032A02	10-32 HEX NUT DIRECTIONAL SERRATION	3.000 EA
11XW1032G06	10-32 X .38, TAPTITE II, HEX WSHR SLTD U	1.000 EA
HW3001B01	003SS CUP WASHER, FOR #8 SCREW	1.000 EA
LD5001A02	CORD & PLUG ASSY 18-3 SJT .33 DIA. 10 AM	1.000 EA
WD4102A01	SR-6L-1 HEYCO STRN RELIEF OR 23MPO6L10 M	1.000 EA
G8CB4500A02	G8-272 BASE COVER,STPD X PLATED	1.000 EA
51XW0832A07	8-32 X .44, TAPTITE II, HEX WSHR SLTD SE	2.000 EA
RM1005A01SP	BUMPER- #2089 (R-R CO)	4.000 EA
15XF1032A10	10-32X5/8 PIN HD PHL TY FSEE JT	4.000 EA
G8EP3900A01SP	ENDPLATE, MACH	1.000 EA
G8EP3900A01SP	ENDPLATE, MACH	1.000 EA
HW5100A06	W2420-025 WVY WSHR (WB)	1.000 EA
HW5100A06	W2420-025 WVY WSHR (WB)	1.000 EA
HA1000A34	DR2463A .02 BRG GUARD B N	1.000 EA
HA3100A14	THRUBOLT 10-32 X 7.875	4.000 EA

Parts List (continued)		
Part Number	Description	Quantity
HA1000A34	DR2463A .02 BRG GUARD B N	1.000 EA
XY1032A02	10-32 HEX NUT DIRECTIONAL SERRATION	4.000 EA
G8FH1800A02	GRINDER GUARD, MACH	1.000 EA
19XW2520A16	SCREW,1/4-20X1 TAPTITE-II OR ROLOC 91	4.000 EA
G8FH1802A02	GRINDER GUARD COVER, MACH	1.000 EA
19XW2520A16	SCREW,1/4-20X1 TAPTITE-II OR ROLOC 91	4.000 EA
HA6048A01SP	SUPPORT, TOOL REST, STAMPED PLATED	1.000 EA
10XN2520A08	1/4-20X1/2 HEX HEAD CAP	1.000 EA
HW1001A25	LOCKWASHER 1/4, ZINC PLT .493 OD, .255 I	1.000 EA
HW1000A25	1/4 SAE FLAT WASHER (FS)	1.000 EA
HA6048A01SP	SUPPORT, TOOL REST, STAMPED PLATED	1.000 EA
10XN2520A08	1/4-20X1/2 HEX HEAD CAP	1.000 EA
HW1001A25	LOCKWASHER 1/4, ZINC PLT .493 OD, .255 I	1.000 EA
HW1000A25	1/4 SAE FLAT WASHER (FS)	1.000 EA
G7AP1010A01SP	TOOL REST, LEFT/RIGHT HAND 11GA H.R. STE	1.000 EA
83XN2520A08	1/4-20 X 1/2 LONG CARRIAGE BOLT	1.000 EA
XY2520A12	1/4-20 HEX NUT, DIRECTIONAL SERRATIONS	1.000 EA
G7AP1010A01SP	TOOL REST, LEFT/RIGHT HAND 11GA H.R. STE	1.000 EA
83XN2520A08	1/4-20 X 1/2 LONG CARRIAGE BOLT	1.000 EA
XY2520A12	1/4-20 HEX NUT, DIRECTIONAL SERRATIONS	1.000 EA
G6AP1002A01SP	SPARK BREAKER-6",7" & 8" GRINDERS	1.000 EA
10XN3118A12	5/16-18 X 3/4 HEX HEAD CAP	1.000 EA
HW1001A31	LOCKWASHER 5/16, ZINC PLT.591 OD, .319 I	1.000 EA
HW1000A31	5/16 SAE FL WSHR NARROW, ID=.344, OD=.62	1.000 EA

Parts List (continued)		
Part Number	Description	Quantity
G6AP1002A01SP	SPARK BREAKER-6",7" & 8" GRINDERS	1.000 EA
10XN3118A12	5/16-18 X 3/4 HEX HEAD CAP	1.000 EA
HW1001A31	LOCKWASHER 5/16, ZINC PLT.591 OD, .319 I	1.000 EA
HW1000A31	5/16 SAE FL WSHR NARROW, ID=.344, OD=.62	1.000 EA
HA6098	WHEEL FLANGE, CAST	2.000 EA
HA6098	WHEEL FLANGE, CAST	2.000 EA
HW3020E04	1/8 X 3/8 A GROOVE PIN (DRIV-LOCK #118	1.000 EA
HW3020E04	1/8 X 3/8 A GROOVE PIN (DRIV-LOCK #118	1.000 EA
G8AP3000A01	A36N5V10 8X1X3/4 36GRIT X	1.000 EA
G8AP3000A02	A60N6V10 8X1X3/4 60GRIT X	1.000 EA
XY7510A12SP	3/4-10 NUT R.H. HEX (NC) ZINC PLATED	1.000 EA
XY7510A62SP	3/4-10 NUT L.H. HEX (NC) (F/S)	1.000 EA
G8FH1801A01SP	GUARD COVER - R.H. 8" GRINDER	1.000 EA
10XN2520A16	1/4-20 X 1 HEX HEAD CAP SCR, ZINC PLATED	4.000 EA
G8FH1803A01SP	GUARD COVER - L.H. 8" GRINDER	1.000 EA
10XN2520A16	1/4-20 X 1 HEX HEAD CAP SCR, ZINC PLATED	4.000 EA
G7AP5001A01	EYE SHIELD ASSEM.-7",8",10",12"&14"GRIND	1.000 EA
SP9000SP	80600BJ A-H OR 1520237-2 TYCO;2PST,125/2	1.000 EA
MJ1000A75	GREASE, POLYREX EM EXXON	0.050 LB
MG1000R01	400-0113 H/F BALDOR BIG RED LAC (5G)	0.017 GA
85XU0407A04	#4-7 X 1/4 DRIVE PIN	2.000 EA
LB1076	LABEL, "ON" AND "OFF"	1.000 EA
LC0279A01	CONNECTION LABEL X	1.000 EA
MG1500G03	PRIMER- S4318E GEMINI 5 GA, HC9068	0.010 GA

Parts List (continued)		
Part Number	Description	Quantity
LB1119	WARNING LABEL	1.000 EA
LB1125C01	STD (STOCK) CARTON LABEL BALDOR WITH FLA	1.000 EA
LB1388A01	CONSOLIDATED GRINDER LABEL FOR 6", 7", 8	1.000 EA
NP0235	NP- 8" GR, BLANK W/CSA	1.000 EA
G0PA1000	PACKAGING GROUP	1.000 EA
MN903	INSTR MANUAL FOR GRINDERS 9/03	1.000 EA

Accessories		
Part Number	Description	Multiplier
GA16RE	PEDESTAL LIGHT INDUSTRIAL,STEEL-RED	A8
GA14R	PEDESTAL FABRICATED STEEL W/SHELVES-RED	A8
GA16R	PEDESTAL IND., CAST IRON 6" - 10" RED	A8
B80	8" 36 GRIT GRINDING WHEEL	A8
B81	8" 60 GRIT GRINDING WHEEL	A8
GA9R	PAIR LIGHTED EYESHIELDS-RED	A8
GA9SR	PAIR LIGHTED EYESHIELD W/ON-OFF-RED	A8
DC8	DUST CONTROL UNIT	A8
BQ1-015-CC	1PH Bake, NEMA 1,110-125 VAC, 50/60Hz	E7
BQ1-015-CP	1PH Brake, Panel 110-125 VAC, 50/60 Hz	E7

GBLY0212

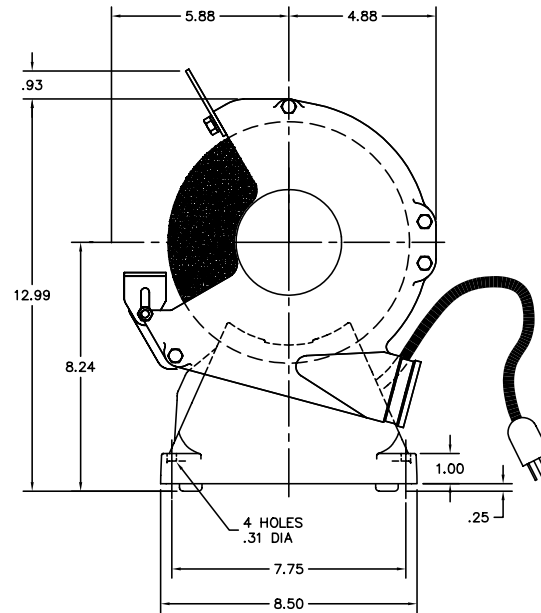
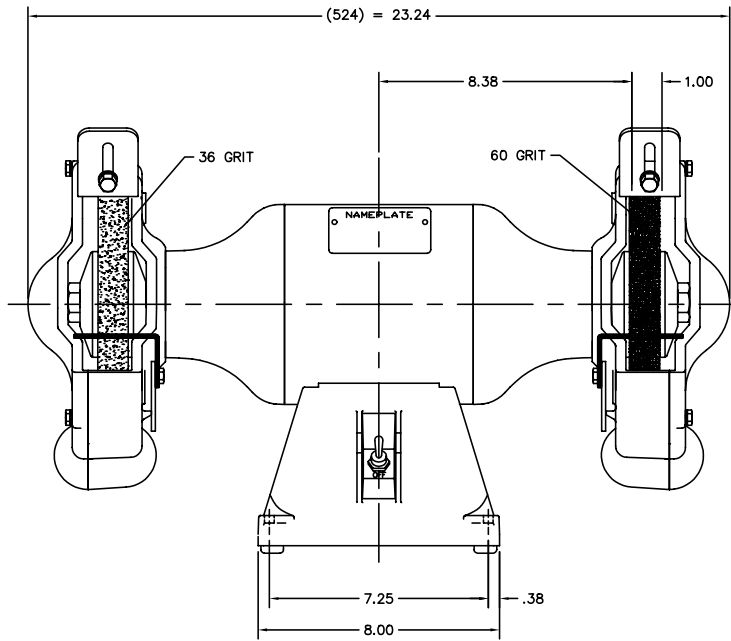

CUSTOMER IS RESPONSIBLE FOR DETERMINING THAT MOTOR PERFORMANCE IS SUITABLE IN THE APPLICATION.

REV. DESC:	OMITTED FELT WSHR HA1025A03 & CHG'D TO SEALED BRGS		
REV. LTR:	H	BY: SSS	REVISED: 10/02/00 1:39
FILE:	AAA00036238		TDR: 0212666
MTL:	-		REF: -

**BALDOR ELECTRIC Co.**

STD 8" UTILITY GRINDER 524C W/115V CORD/PLUG

GBLY0212



