

BALDOR® • RELIANCE

Product Information Packet

AEM3787-4

5HP,1750RPM,3PH,60HZ,215,0735M,TEFC,F1

Copyright © All product information within this document is subject to Baldor Electric Company copyright © protection, unless otherwise noted.

Part Detail									
Revision:	AA	Status:	PRD/A	Change #:		Proprietary:	No		
Type:	AC	Prod. Type:	0735M	Elec. Spec:	07WGW138	CD Diagram:			
Enclosure:	TEFC	Mfg Plant:		Mech. Spec:	07G087	Layout:			
Frame:	215	Mounting:	F1	Poles:	04	Created Date:			
Base:	RG	Rotation:	R	Insulation:	F	Eff. Date:	04-15-2011		
Leads:	3#14	Literature:		Elec. Diagram:		Replaced By:			
Nameplate NP1404E									
CAT.NO.	AEM3787-4								
SPEC.	07G87W138								
VOLTS	460								
AMP	6.4								
RPM	1750	HP	5						
FRAME	215	HZ	60	PH	3				
SER.F.	1.00	CODE	G	DES	B	CL	F		
NEMA-NOM-EFF	87.5	PF	84						
G.MIN.EFF	85.5	CC							
RATING	65C AMB-CONT								
LUBRICATION	POLYREX EM								
DE	6307	ODE	6206						
ENCL	TEFC	SER. #							
	MEETS GM-7EQ								

Parts List		
Part Number	Description	Quantity
SA020736	SA 07G87W138	1.000 EA
RA016789	RA 07G87W138	1.000 EA
HW3201A05	3/8-16 EYEBOLT	1.000 EA
09CB1002A05	CONDUIT BOX, 1.00 N.P.T.	1.000 EA
07GS1003	GASKET, CONDUIT BOX	1.000 EA
51XW2520A12	.25-20 X .75, TAPTITE II, HEX WSHR SLTD	2.000 EA
11XW1032G06	10-32 X .38, TAPTITE II, HEX WSHR SLTD U	1.000 EA
HW3001B01	003SS CUP WASHER, FOR #8 SCREW	1.000 EA
37EP1100A55	FR ENDPLATE MACH	1.000 EA
HW4500A19	1/4-28X1/4 SLOTTED PLUG F/S	1.000 EA
HW4500A20	1/8NPT SL PIPE PLUG	2.000 EA
HA4001A01SP	DRAIN PLUG, PLASTIC (MICRO PLAS)	1.000 EA
HW5100A06	W2420-025 WVY WSHR (WB)	1.000 EA
37EP1101A28	PU ENDPLATE MACH	1.000 EA
HW4500A19	1/4-28X1/4 SLOTTED PLUG F/S	1.000 EA
HW4500A20	1/8NPT SL PIPE PLUG	2.000 EA
HA3104A32	THRUBOLT- 5/16-18 X12.750	4.000 EA
XY3118A12	5/16-18 HEX NUT DIRECTIONAL SERRATION	4.000 EA
51XB1214A20	12-14X1.25 HXWSSLD SERTYB	1.000 EA
07FH4007SP	IEC FH W/GRSR, NOTCH @ 6:00 & 3 FAN CVR	1.000 EA
WD4100A03	DE-750 HEYCO PLUG 62MP0750 MICRO PLASTIC	1.000 EA
51XW1032A06	10-32 X .38, TAPTITE II, HEX WSHR SLTD S	3.000 EA
12CB1500A10	CONDUIT BOX LID, .31 MTG HOLES	1.000 EA
12GS1002	GASKET, CONDUIT BOX LID, NEOP	1.000 EA

Parts List (continued)		
Part Number	Description	Quantity
10XN2520A24	1/4-20X 1 1/2 HEX HD X	2.000 EA
HA1005A02SP	SLINGER, OD 2.00, ID 1.14, 206 BRG,	1.000 EA
HA1005A07SP	SLINGER, OD 2.25, ID 1.344, 307 BRG	1.000 EA
HW2501E18	KEY, 1/4 SQ X 2.000	1.000 EA
HA7000A02	KEY RETAINER RING, 1 1/8 DIA, 1 3/8 DIA	1.000 EA
MJ5001A01	46-665 RED SEALER	0.001 QT
LB1115	LABEL,LIFTING DEVICE	1.000 EA
85XU0407S04	4X1/4 U DRIVE PIN STAINLESS	2.000 EA
WD1000B03	BURNDY YAV14 TERML (1M/PK)	3.000 EA
MJ1000A75	GREASE, POLYREX EM EXXON	0.050 LB
37FN3002A01SP	EXFN, PLASTIC, 9.00 OD, 1.155 ID	1.000 EA
MG1025G02	PAINT, 782-02 WILKOFASST LIGHT GREY EPOXY	0.036 GA
LB1119	WARNING LABEL	1.000 EA
LB1125C01	STD (STOCK) CARTON LABEL BALDOR WITH FLA	1.000 EA
NP1404E	SS UL CSA CC "AUTOMOTIVE"	1.000 EA
LC0006	CONNECTION LABEL	1.000 EA
07PA1011	PKG GRP, 07 CAST IRON PK1181	1.000 EA
10XL3808A28	3/8 X 1 3/4" LAG SCREW	2.000 EA

Performance Data at 460V, 60Hz, 5.0HP (Typical performance - Not guaranteed values)

General Characteristics							
Full Load Torque:	15.0 LB-FT			Start Configuration:	DOL		
No-Load Current:	2.4 Amps			Break-Down Torque:	40.0 LB-FT		
Line-line Res. @ 25°C.:	2.124 Ohms A Ph / 0.0 Ohms B Ph			Pull-Up Torque:	20.0 LB-FT		
Temp. Rise @ Rated Load:	40 C			Locked-Rotor Torque:	29.0 LB-FT		
Temp. Rise @ S.F. Load:				Starting Current:	38.6 Amps		
Load Characteristics							
% of Rated Load	25	50	75	100	125	150	S.F.
Power Factor:	51.0	70.0	80.0	84.0	85.0	85.0	0.0
Efficiency:	85.4	89.4	89.9	89.3	88.0	86.3	0.0
Speed:	1790.0	1781.0	1770.0	1761.0	1748.0	1734.0	0.0
Line Amperes:	2.8	3.7	5.0	6.4	7.7	9.3	0.0

Performance Graph at 460V, 60Hz, 5.0HP Typical performance - Not guaranteed values

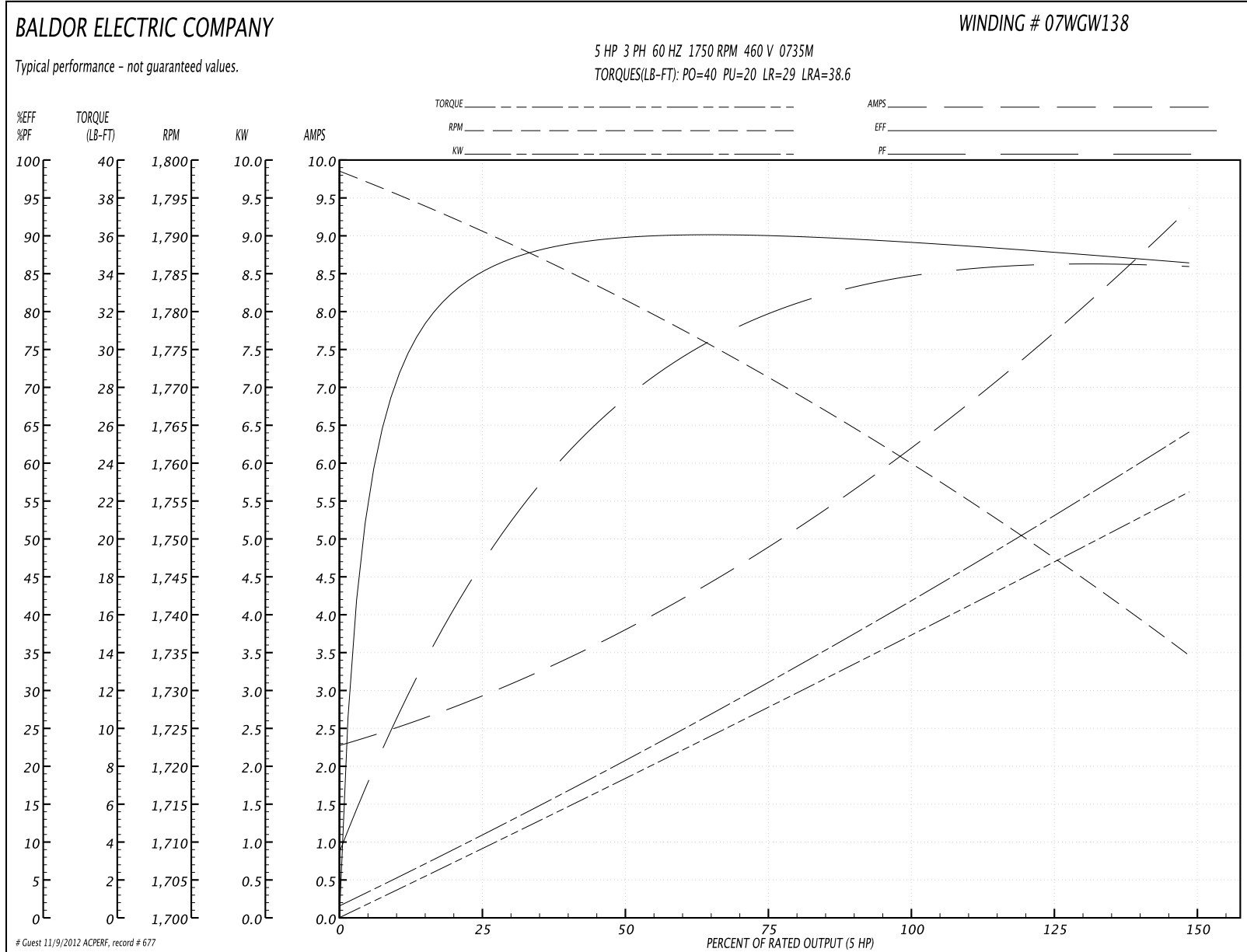

07LYG087

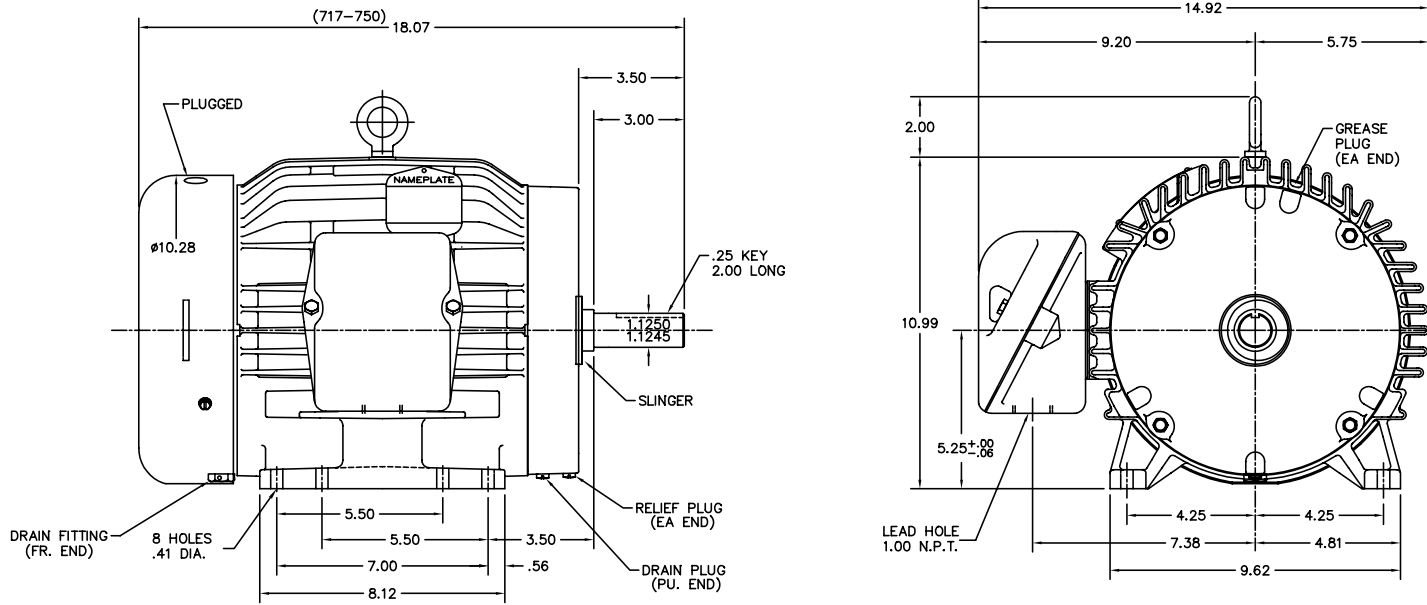

CUSTOMER IS RESPONSIBLE FOR DETERMINING THAT MOTOR PERFORMANCE IS SUITABLE IN THE APPLICATION.

REV. DESC: CHG'D FAN COVER TO 07FH4004 TO 07FH4007				BALDOR ELECTRIC Co.
REV. LTR: G	BY: YD	REVISED: 07/17/00 2:22	TDR: 0214599	
FILE: AAA00016238			REF: -	
MTL: -				

HORZ 213-5 TEFC 307M - GM SPECS

07LYG087

CD0006

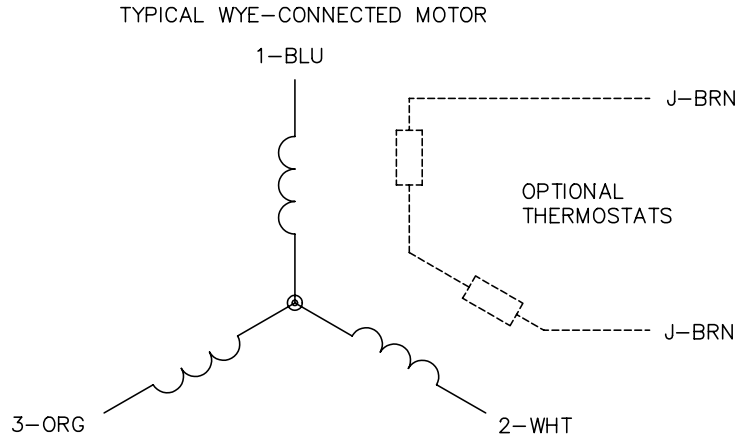

NOTES:

1. THREE LEAD MOTOR MAY BE EITHER WYE CONNECTED OR DELTA CONNECTED.
2. INTERCHANGE ANY TWO LINE LEADS TO REVERSE ROTATION.
3. OPTIONAL THERMOSTATS ARE PROVIDED WHEN SPECIFIED.
4. ACTUAL NUMBER OF INTERNAL PARALLEL CIRCUITS MAY VARY.
5. LEAD COLORS ARE OPTIONAL. LEADS MUST BE NUMBERED AS SHOWN.

REV. DESC: REVISE TO SHOW OPTIONAL COLORS			
REV. LTR: D	BY: JLP	REVISED: 01/21/99 4:02	TDR: 0171435
9000D		FILE: AAA00005141	MDL: -
		MTL: -	

BALDOR ELECTRIC Co.

3PH, SV, 3 LEADS, WYE OR DELTA CONNECTED

CD0006