

BALDOR® • RELIANCE

Product Information Packet

AOM3554T

1.5 AIR OVERHP, 1735RPM, 3PH, 60HZ, 145T, 352

Copyright © All product information within this document is subject to Baldor Electric Company copyright © protection, unless otherwise noted.

Part Detail							
Revision:	C	Status:	PRD/A	Change #:		Proprietary:	No
Type:	AC	Prod. Type:	3520M	Elec. Spec:	35WGP801	CD Diagram:	
Enclosure:	TEAO	Mfg Plant:		Mech. Spec:	35K695	Layout:	
Frame:	145T	Mounting:	F1	Poles:	04	Created Date:	08-13-2010
Base:	RG	Rotation:	R	Insulation:	F	Eff. Date:	02-29-2012
Leads:	9#18 36" LG	Literature:	Y	Elec. Diagram:		Replaced By:	

Nameplate NP1256L									
CAT.NO.	AOM3554T								
SPEC.	35K695P801G1								
HP	1.5 AIR OVER								
VOLTS	208-230/460								
AMP	5-4.6/2.3								
RPM	1735								
FRAME	145T	HZ	60	PH	3				
SER.F.	1.00	CODE	L	DES	B	CLASS	F		
NEMA-NOM-EFF	81.5	PF	74						
RATING	40C AMB-CONT								
CC				USABLE AT 208V					
DE	6205	ODE			6203				
ENCL	TEAO	SN							
	1500 FPM AT 66 CFM								

Parts List		
Part Number	Description	Quantity
SA201727	SA 35K695P801G1	1.000 EA
RA189022	RA 35K695P801G1	1.000 EA
NS2512A01	INSULATOR, CONDUIT BOX X	1.000 EA
35CB3007	35 CB CASTING W/.88 DIA. LEAD HOLE	1.000 EA
36GS1000SP	GASKET-CONDUIT BOX, .06 THICK #SV-330 LE	1.000 EA
51XB1016A07	10-16 X 7/16 HXWSSLD SERTYB	2.000 EA
11XW1032G06	10-32 X .38, TAPTITE II, HEX WSHR SLTD U	1.000 EA
35EP3100M68	STD FR EP-TENV-35L OR M--203 BRG-W/GREAS	1.000 EA
HW4500A01	1641B(ALEMITE)400 UNIV, GREASE FITT	1.000 EA
HW5100A03SP	WAVY WASHER (W1543-017)	1.000 EA
35EP3101A08	PU ENDPLATE, MACH	1.000 EA
HW4500A01	1641B(ALEMITE)400 UNIV, GREASE FITT	1.000 EA
51XN1032A20	10-32 X 1 1/4 HX WS SL SR	2.000 EA
XY1032A02	10-32 HEX NUT DIRECTIONAL SERRATION	4.000 EA
35CB4521GX	CONDUIT BOX LID KIT	1.000 EA
51XW0832A07	8-32 X .44, TAPTITE II, HEX WSHR SLTD SE	4.000 EA
HW2501D13SP	KEY, 3/16 SQ X 1.375	1.000 EA
HA7000A01	KEY RETAINER 7/8" DIA SHAFT	1.000 EA
85XU0407S04	4X1/4 U DRIVE PIN STAINLESS	2.000 EA
MJ1000A75	GREASE, POLYREX EM EXXON	0.050 LB
MG1000G27	PAINT- S9282E CHARCOAL GREY	0.017 GA
HA3100A15	THRUBOLT 10-32 X 8.375	4.000 EA
LB1125C01	STD (STOCK) CARTON LABEL BALDOR WITH FLA	1.000 EA
LC0005E01	CONN.DIA./WARNING LABEL (LC0005/LB1119)	1.000 EA

Parts List (continued)		
Part Number	Description	Quantity
NP1256L	ALUM UL CSA CC	1.000 EA
PA1000	PACKING GROUP 3500 SHORT	1.000 EA

Accessories		
Part Number	Description	Multiplier
35-8762	C FACE KIT	A8
35EP1506A01SP	D-FLANGE KIT	A8

Performance Data at 460V, 60Hz, 1.5HP (Typical performance - Not guaranteed values)

General Characteristics							
Full Load Torque:	4.5 LB-FT			Start Configuration:	DOL		
No-Load Current:	1.57 Amps			Break-Down Torque:	18.6 LB-FT		
Line-line Res. @ 25°C.:	12.9 Ohms A Ph / 0.0 Ohms B Ph			Pull-Up Torque:	12.3 LB-FT		
Temp. Rise @ Rated Load:	71 C			Locked-Rotor Torque:	14.1 LB-FT		
Temp. Rise @ S.F. Load:	81 C			Starting Current:	17.5 Amps		
Load Characteristics							
% of Rated Load	25	50	75	100	125	150	S.F.
Power Factor:	32.0	51.0	65.0	74.0	81.0	85.0	0.0
Efficiency:	65.9	77.0	80.9	81.5	81.0	79.7	0.0
Speed:	1786.0	1770.0	1753.0	1735.0	1714.0	1692.0	0.0
Line Amperes:	1.62	1.76	1.99	2.3	2.66	3.1	0.0

Performance Graph at 460V, 60Hz, 1.5HP Typical performance - Not guaranteed values

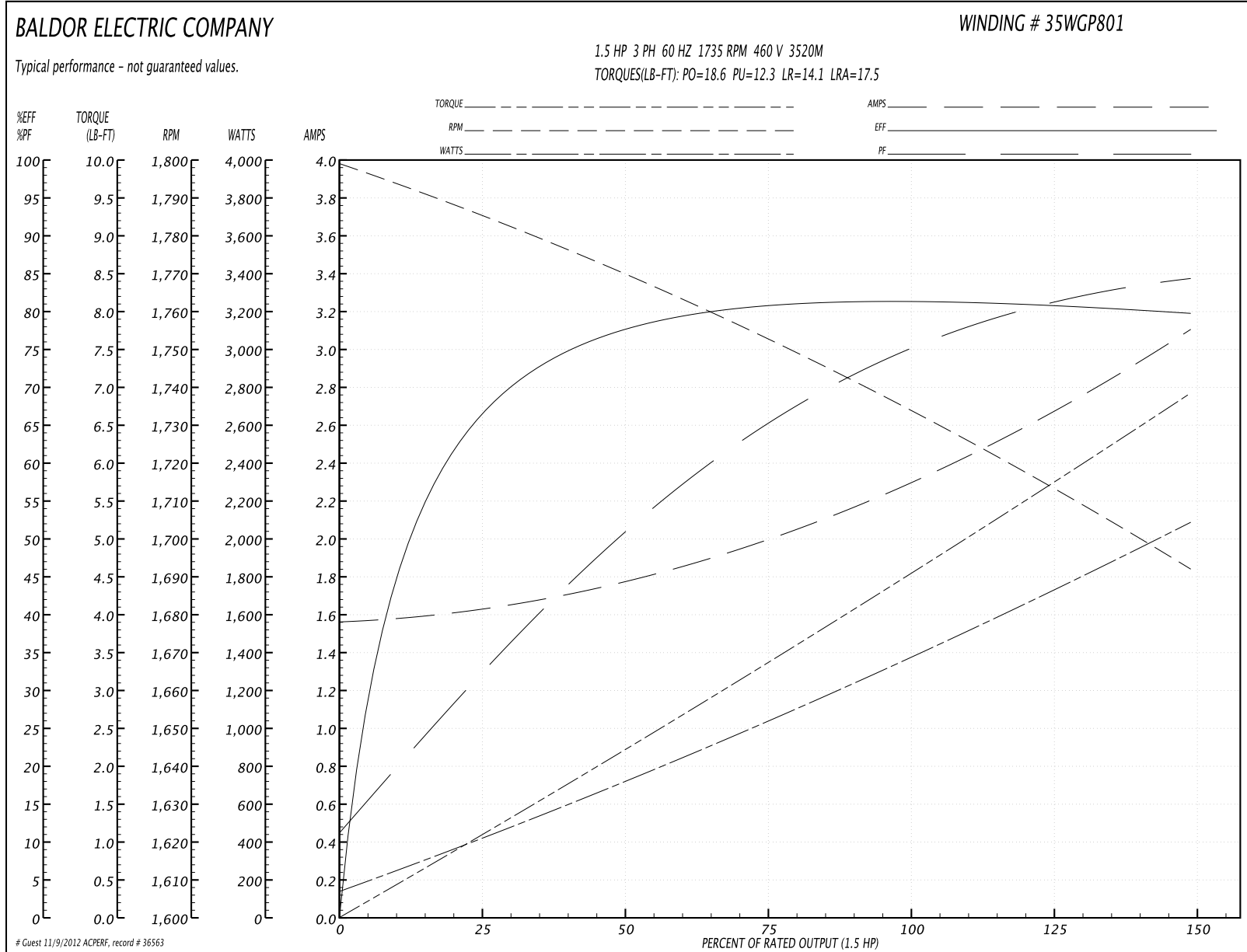

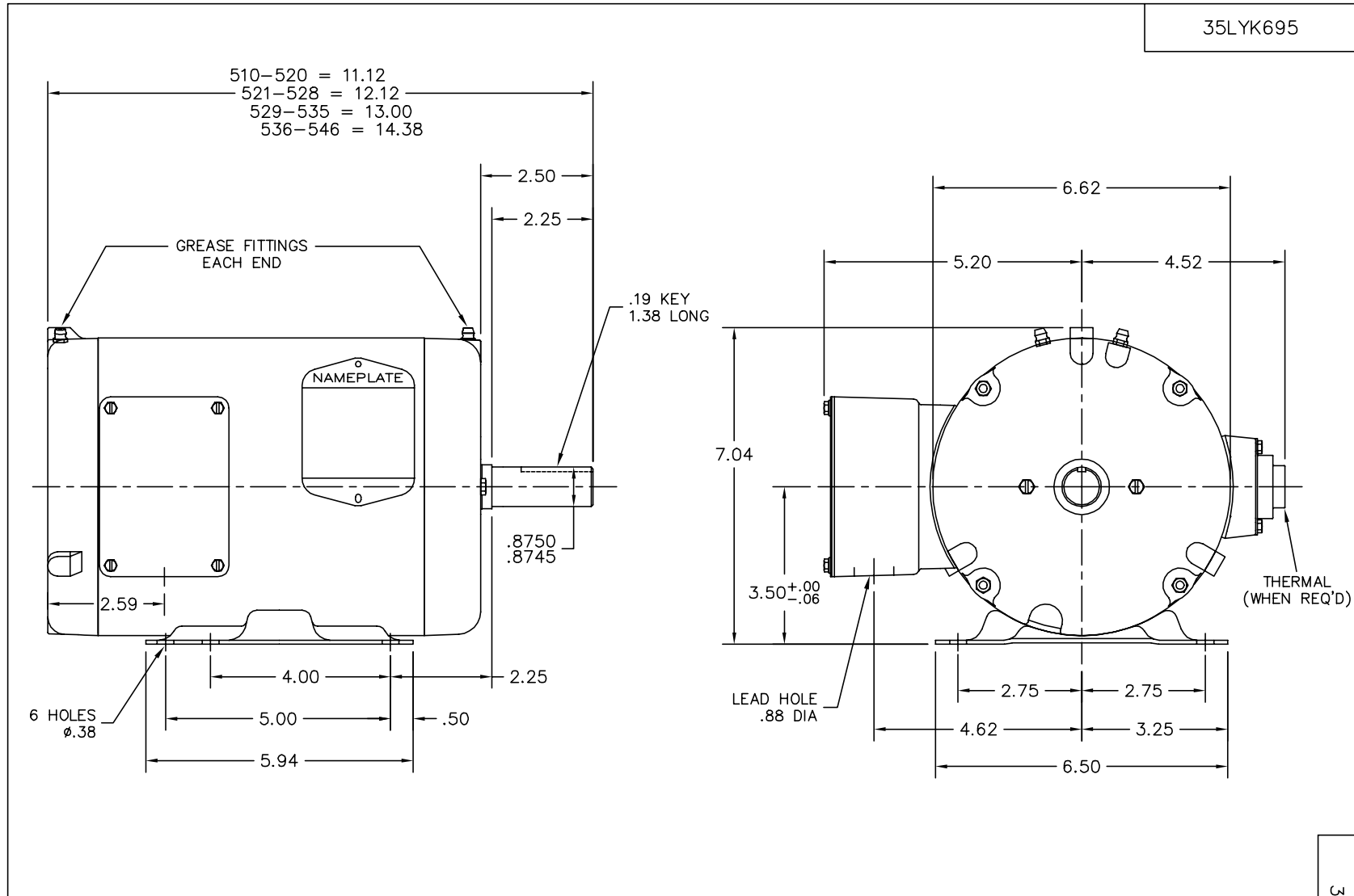

CUSTOMER IS RESPONSIBLE FOR DETERMINING THAT MOTOR PERFORMANCE IS SUITABLE IN THE APPLICATION.

REV. DESC: UPDATE LAYOUT PER BOM, FREP & BASE		
REV. LTR: D	VERSION: 01	TDR: 000000460581
35LYK695	FILE: \AAA\00014\403	REVISED: 09: 29: 05 03/27/2008
	MTL: -	BY: ENODIDO

BALDOR • DODGE • RELIANCE

HORZ 35M 143-5T TEAO W/LOCKED PU BRG

SH 1 of 1

35LYK695

CD0005



LOW VOLTAGE
(2Y)

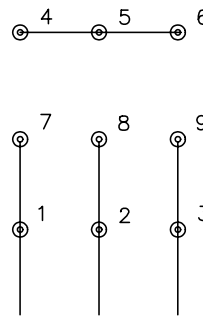

LINE

HIGH VOLTAGE
(1Y)

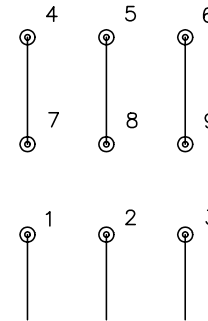

LINE

NOTES:

1. INTERCHANGE ANY TWO LINE LEADS TO REVERSE ROTATION.
2. OPTIONAL THERMOSTATS ARE PROVIDED WHEN SPECIFIED.
3. ACTUAL NUMBER OF INTERNAL PARALLEL CIRCUITS MAY BE A MULTIPLE OF THOSE SHOWN ABOVE.
4. LEAD COLORS ARE OPTIONAL. LEADS MUST ALWAYS BE NUMBERED AS SHOWN.

REV. DESC: REVISE TO SHOW OPTIONAL COLORS			
REV. LTR: E	BY: JLP	REVISED: 01/19/99 10:15	TDR: 0171435
90000		FILE: AAA00005140	MDL: -
		MTL: -	

BALDOR ELECTRIC Co.

3PH, DV, 9 LEADS

CD0005