

BALDOR® • RELIANCE

Product Information Packet

CD5375

.75HP, 1750RPM, DC, 56C, 3528D, TEFC, F1

Copyright © All product information within this document is subject to Baldor Electric Company copyright © protection, unless otherwise noted.

Part Detail							
Revision:	J	Status:	PRD/A	Change #:		Proprietary:	No
Type:	DC	Prod. Type:		Elec. Spec:	35WGZ389	CD Diagram:	
Enclosure:	TEFC	Mfg Plant:		Mech. Spec:	35P442	Layout:	
Frame:	56C	Mounting:	F1	Poles:	2///	Created Date:	
Base:	RG	Rotation:	R	Insulation:	F	Eff. Date:	01-31-2007
Field Type:	Shunt	Literature:		Elec. Diagram:		Replaced By:	

Nameplate NP0111L			
CAT.NO.	CD5375		
SPEC.	35P442Z389		
HP	.75	ENCL	TEFC
RPM	1750		
FRAME	56C	TYPE	SH3528D
ARM V	90	ARM A	8
FLD V	100/50	FLD A	.6/1.2
INSUL	F	AMB.	40C
DUTY	CONT	SUPPLY	1.3
BRG/DE	6205	BRG/ODE	6203
BRUSHES	2/BP5000T07		
		BLANK	
SER.			
BLANK			
APRV-CSA		APRV-UL	

Parts List		
Part Number	Description	Quantity
SA046569	SA 35P442Z389	1.000 EA
AA005346	AA 35P442Z389	1.000 EA
MH2001A01B19	GLASTIC SHEET .093 X 1.188 X	0.101 LB
BP5000T07SP	CARBON BRUSH - SCHUNK GRADE 3971	1.000 EA
11XW1032G06	10-32 X .38, TAPTITE II, HEX WSHR SLTD U	1.000 EA
HW3001B01	003SS CUP WASHER, FOR #8 SCREW	1.000 EA
35EP3112A02	FR ENDPLATE, MACH	1.000 EA
HW5100A03SP	WAVY WASHER (W1543-017)	1.000 EA
35EP3301A01	PU ENDPLATE, MACH	1.000 EA
51XN1032A20	10-32 X 1 1/4 HX WS SL SR	2.000 EA
BP5201A14SP	BRUSH HOLDER ASSY	1.000 EA
80XN1032A03	10-32 X 3/16 SET SCREW	2.000 EA
35FN3002A05SP	EXFN, PLASTIC, 6.376 OD, .638 ID	1.000 EA
51XB1214A16	12-14X1.00 HXWSSLD SERTYB	1.000 EA
35FH5001A10SP	FAN COVER ASS'Y TEFC HORZ	1.000 EA
51XW1032A06	10-32 X .38, TAPTITE II, HEX WSHR SLTD S	3.000 EA
35CB4506	CONDUIT BOX LID, STAMPED	1.000 EA
35GS1010	CONDUIT BOX LID, GASKET	1.000 EA
51XW0832A07	8-32 X .44, TAPTITE II, HEX WSHR SLTD SE	2.000 EA
HW2501D13SP	KEY, 3/16 SQ X 1.375	1.000 EA
HA7000A04	KEY RETAINER 0.625 DIA SHAFTS	1.000 EA
WD4102A06	SR-7K-2 HEYCO STRN RELIEF OR 23MP07K20 M	1.000 EA
WD4100A17	PLUG STIMPSON D4036	1.000 EA
MG1000G27	PAINT- S9282E CHARCOAL GREY	0.017 GA

Parts List (continued)		
Part Number	Description	Quantity
10XF0440S02	04-40 X 1/8 TYPE F HEX HD STAINLESS STIC	2.000 EA
MJ5004A05	#242-21 LOCTITE GENERAL PURPOSE MED. STR	0.001 EA
HA3101A22	THRUBOLT 1/4-20 X 9.000	4.000 EA
LB5040	INSTRUCTION TAG, AC & DC	1.000 EA
LB1119	WARNING LABEL	1.000 EA
LB1125C01	STD (STOCK) CARTON LABEL BALDOR WITH FLA	1.000 EA
LC0860	CONN. DIAGRAM-DC(SHUNT WOUND MOTOR)	1.000 EA
NP0111L	NP STD LASER ENGRAVED DC MOTORS, UL CSA	1.000 EA
27PA1001	PACKAGING GROUP	1.000 EA

Accessories		
Part Number	Description	Multiplier
TK3500	TACHO MOUTING KIT TK3500	A8

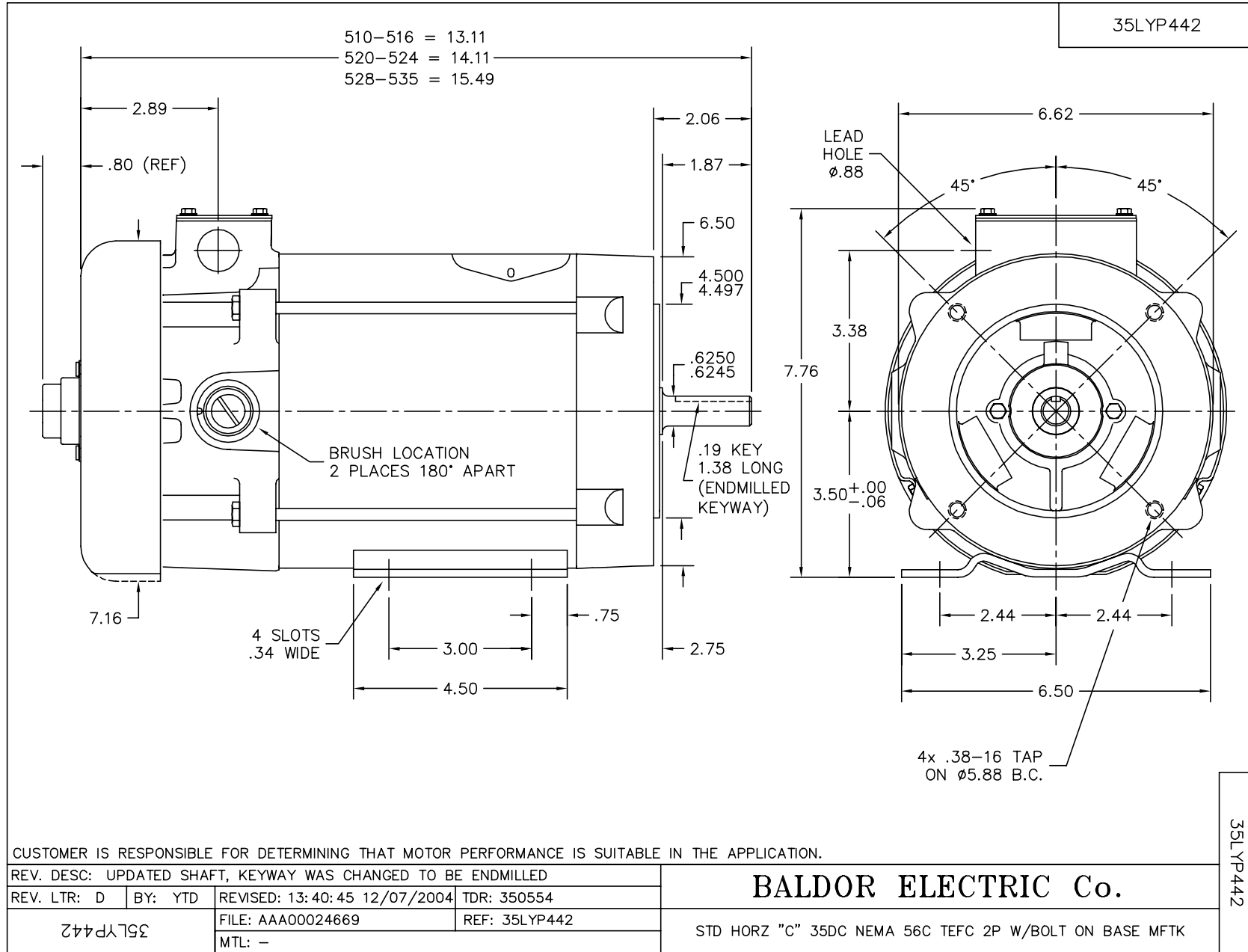

CD0860C01

SHUNT WOUND

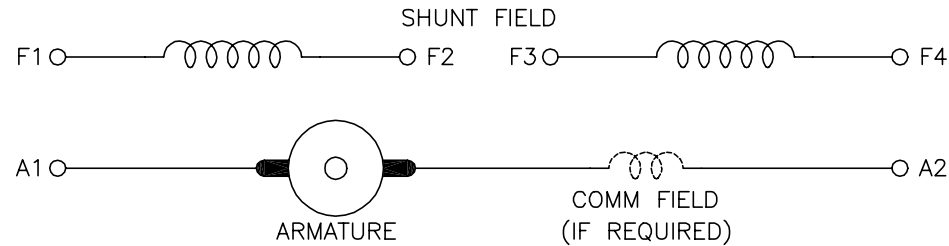

CONNECTION	DIRECTION OF ROTATION			
	CWDE		CCWDE	
	POS TERM (+)	NEG TERM (-)	POS TERM (+)	NEG TERM (-)
HIGH VOLTAGE	A1 F1 CONNECT F2 & F3	A2 F4	A2 F1 CONNECT F2 & F3	A1 F4
LOW VOLTAGE	A1 F1 & F3	A2 F2 & F4	A2 F1 & F3	A1 F2 & F4

NOTES:

1. LIMIT STARTING INRUSH CURRENT TO NOT MORE THAN 3 TIMES RATED AMPERES BY ENERGIZING THE FULL SHUNT FIELD BEFORE BRINGING THE ARMATURE VOLTAGE UP SLOWLY OR IN STEPS.
2. OPTIONAL FIELD REOSTAT MAY BE CONNECTED IN SERIES WITH THE SHUNT FIELD.
3. OPTIONAL THERMOSTAT LEADS ARE MARKED J,J.

REV. DESC: NEW, REPLACE CD0860			
REV. LTR: -	BY: JLP	REVISED: 15: 35: 22 11/03/2004	TDR: 347796
100098000		FILE: AAA00121477	REF: CD0860C01
		MTL: -	

BALDOR ELECTRIC Co.

DC CONNECTION DIAGRAM, SHUNT FIELD, 6 LEAD, DUAL VOLTAGE

CD0860C01