

BALDOR® • ***RELIANCE***

Product Information Packet

CDP3326

.5HP,1750RPM,DC,56C,3336P,TENV,F1

Copyright © All product information within this document is subject to Baldor Electric Company copyright © protection, unless otherwise noted.

Part Detail							
Revision:	X	Status:	PRD/A	Change #:		Proprietary:	No
Type:	DC	Prod. Type:		Elec. Spec:	33WGZ139	CD Diagram:	
Enclosure:	TENV	Mfg Plant:		Mech. Spec:	33-2051	Layout:	
Frame:	56C	Mounting:	F1	Poles:	///	Created Date:	
Base:	RG	Rotation:	R	Insulation:	F	Eff. Date:	05-17-2012
Field Type:		Literature:		Elec. Diagram:		Replaced By:	

Nameplate NP0891L								
CAT.NO.	CDP3326							
SPEC.	33-2051Z139							
HP	.5	ENCL			TENV			
RPM	1750							
FRAME	56C	TYPE			3336P			
ARM V	180	ARM A			2.5			
FLD V		FLD A						
INSUL	F	AMB.			40			
DUTY	CONT	SUPPLY			1.3			
BRG/DE	6203	BRG/ODE			6203			
BRUSHES	2/BP5011CV01							
	BLANK							
SER.								
BLANK	IP44							
APRV-CE	Y	APRV-CSA			Y	APRV-UL		Y

Parts List		
Part Number	Description	Quantity
SA005043	SA 33-2051Z139	1.000 EA
AA002692	AA 33-2051Z139	1.000 EA
BP5011CV01SP	CARBON BRUSH - 33P, 180V	1.000 EA
BP5012A04SP	BRUSH SPRING FOR DC MOTORS	1.000 EA
33CB5000A03	33P BOX & LEAD ASSY	1.000 EA
33GS1006A01	GASKET CONDUIT BOX (LEXIDE)	1.000 EA
51XT0832A08	8-32 X 1/2 TY23 HXWS SLDSR	3.000 EA
51XW0832G07	8-32 X 7/16 TY23 HXWS SLDSR GR	1.000 EA
51XW0832A07	8-32 X .44, TAPTITE II, HEX WSHR SLTD SE	4.000 EA
33EP3101A04	FR ENDPLATE, MACH	1.000 EA
33CB4501A01SP	BRUSH INSPECTION COVER	2.000 EA
33GS1005A01SP	GASKET, BRUSH INSP. COVERELECTRICLY NON-	2.000 EA
51XW0832A07	8-32 X .44, TAPTITE II, HEX WSHR SLTD SE	4.000 EA
HW5100A03SP	WAVY WASHER (W1543-017)	1.000 EA
33EP3302A10	PU ENDPLATE, MACH	1.000 EA
51XN1032A20	10-32 X 1 1/4 HX WS SL SR	2.000 EA
HA6887	SHAFT PROTECTOR STAMPED STEEL 20 GA.	1.000 EA
10XN2520A06	1/4 20X3/8 HX HD CAP	2.000 EA
34CB4512	34 CB LID	1.000 EA
34GS1001	GASKET, STD CONDUIT BOX LID (LEXIDE)	1.000 EA
51XW0832A07	8-32 X .44, TAPTITE II, HEX WSHR SLTD SE	4.000 EA
HW2501D13SP	KEY, 3/16 SQ X 1.375	1.000 EA
HA7000A04	KEY RETAINER 0.625 DIA SHAFTS	1.000 EA
HW3001B02	BRASS CUP WASHER W/GROUND SYMBOL TAB,	1.000 EA

Parts List (continued)		
Part Number	Description	Quantity
MG1000G27	PAINT- S9282E CHARCOAL GREY	0.013 GA
10XF0440S02	04-40 X 1/8 TYPE F HEX HD STAINLESS STIC	2.000 EA
33RK5004SP	ROCKERARM	1.000 EA
HA3100S03	THRUBOLT- 10-32 X 10.625 302 OR 303 SS	2.000 EA
LB1119	WARNING LABEL	1.000 EA
LB1125C01	STD (STOCK) CARTON LABEL BALDOR WITH FLA	1.000 EA
LB5040	INSTRUCTION TAG, AC & DC	1.000 EA
LC0194	CONNECTION LABEL FOR TYPE PM-DC MOTOR W/	1.000 EA
NP0891L	NP STD LASER ENGRAVED DC MTRS, UL CSA CE	1.000 EA
27PA1001	PACKAGING GROUP	1.000 EA

Accessories		
Part Number	Description	Multiplier
TK3300	TACHO MOUNTING KIT TK3300	A8
TK3300-HPU	HPU10 MOUNTING KIT 33P/34P TENV	A8

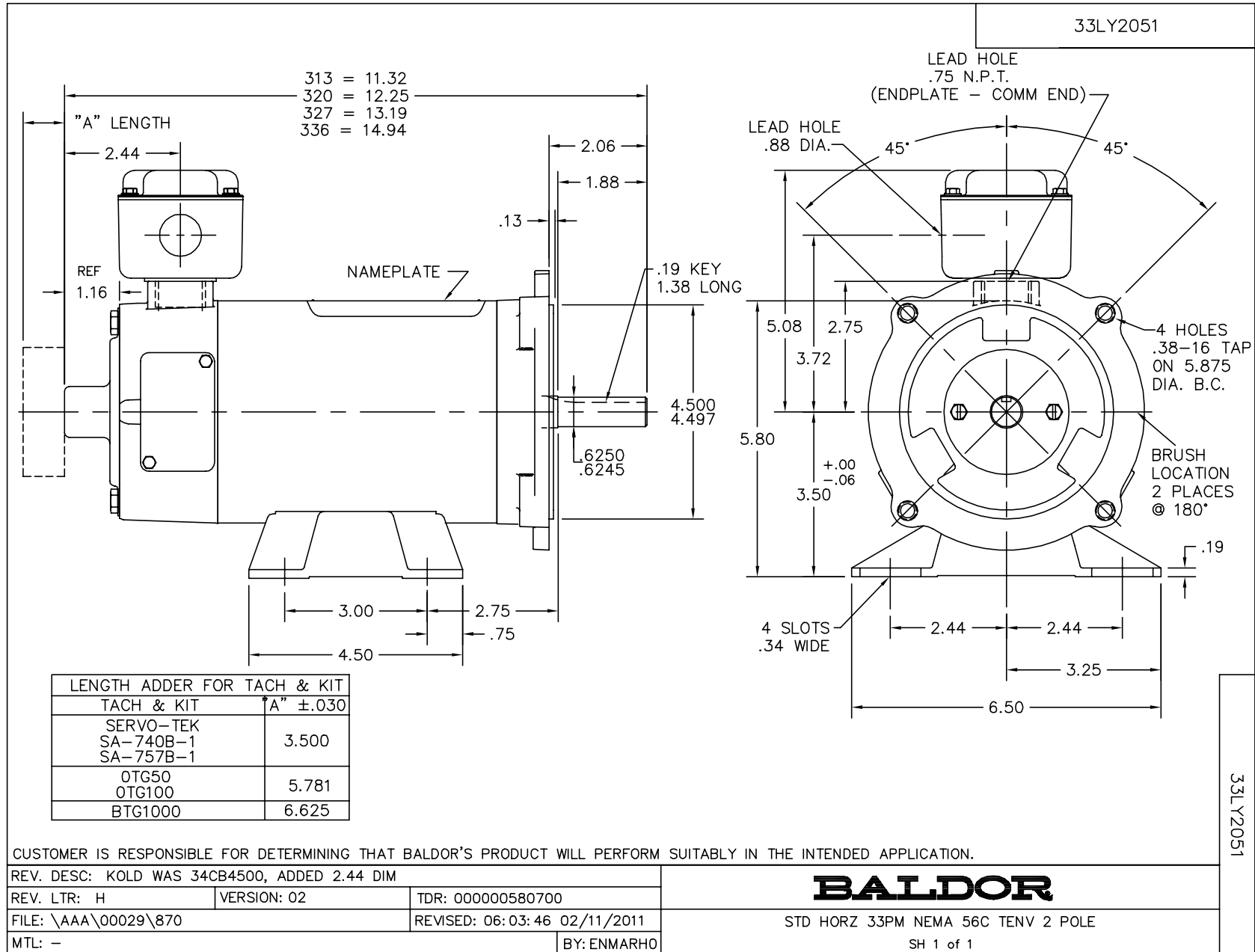

CD0194

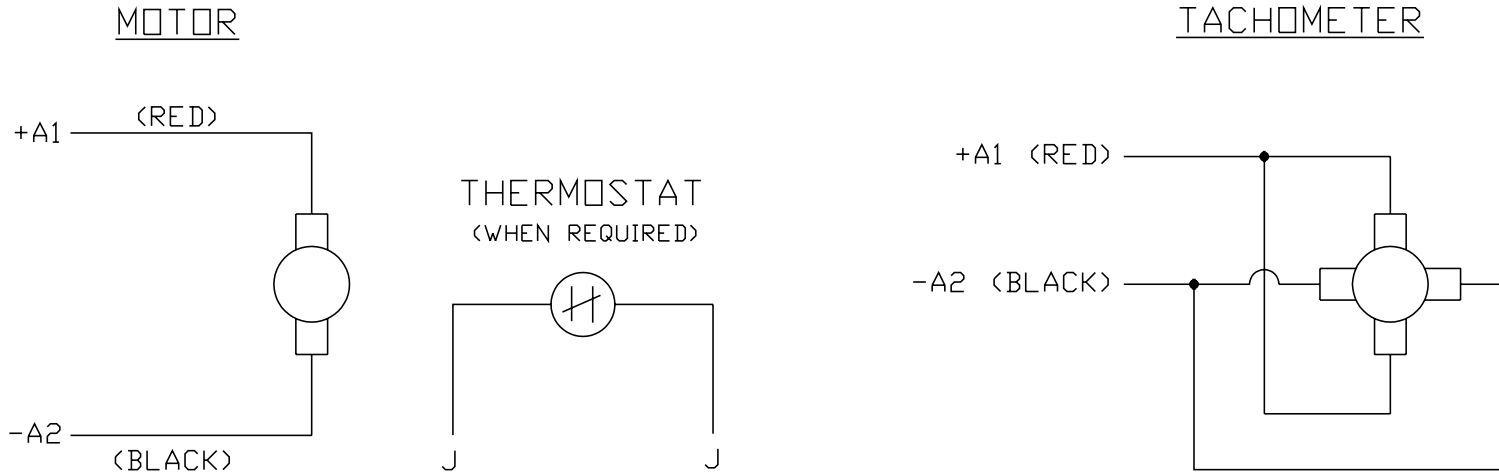

NOTES:

1. CCW ROTATION AS SHOWN FACING COMMUTATOR END. TO REVERSE MOTOR ROTATION OR TACHOMETER OUTPUT POLARITY INTERCHANGE LEADS A1(RED) & A2(BLACK)
2. LEAD COLORS FOR REFERENCE ONLY & NOT SPECIFIED BY THIS DRAWING. LEAD COLORS SPECIFIED BY LAYOUT DRAWING & BILL OF MATERIAL ONLY.

MATL: -			
REV: E	ADDED NOTE "LEAD COLORS FOR REFERENCE ONLY &..."		
CD0194	SCALE: -	BY: CK	REVISED: 07/28/95
	FILE: AAA00004503	TDR: 0078737	

BALDOR ELECTRIC Co.

CD TYPE P DC PERMANENT MAGNET MOTORS AND TACHOMETERS

CD0194