

BALDOR® • ***RELIANCE***

Product Information Packet

CDPT3445

1HP,1750RPM,DC,56C,3435P,TEFC,F1

Copyright © All product information within this document is subject to Baldor Electric Company copyright © protection, unless otherwise noted.

Part Detail							
Revision:	M	Status:	PRD/A	Change #:		Proprietary:	No
Type:	DC	Prod. Type:		Elec. Spec:	34WG3675	CD Diagram:	
Enclosure:	TEFC	Mfg Plant:		Mech. Spec:	34-6432	Layout:	
Frame:	56C	Mounting:	F1	Poles:	///	Created Date:	
Base:	RG	Rotation:	R	Insulation:	F	Eff. Date:	10-20-2008
Field Type:		Literature:		Elec. Diagram:		Replaced By:	

Nameplate NP0891L

CAT.NO.	CDPT3445							
SPEC.	34-6432-3675							
HP	1	ENCL			TEFC			
RPM	1750							
FRAME	56C	TYPE			3435P			
ARM V	90	ARM A			10			
FLD V		FLD A						
INSUL	F	AMB.			40C			
DUTY	CONT	SUPPLY			1.5			
BRG/DE	6203	BRG/ODE			6203			
BRUSHES	2/BP5000BK08							
	BLANK							
SER.								
BLANK								
APRV-CE	Y	APRV-CSA			Y	APRV-UL		Y

Parts List		
Part Number	Description	Quantity
SA005394	SA 34-6432-3675	1.000 EA
AA003043	AA 34-6432-3675	1.000 EA
BP5000BK08SP	CARBON BRUSH - GRADE SA-35	1.000 EA
HA3210B66	.125 DIA X .281 (AUTO)	2.000 EA
11XW1032G06	10-32 X .38, TAPTITE II, HEX WSHR SLTD U	1.000 EA
HW3001B01	003SS CUP WASHER, FOR #8 SCREW	1.000 EA
34EP3103B03	FR. ENDPLATE, MACH	1.000 EA
HA6341A01	TG-300 TACH. ADAPTER MACH'D FOR 34 FRAME	1.000 EA
84XN2520J12	1/4-20 X 3/4 SOC.HD CAP SCR	4.000 EA
HW1002A25	WASHER, 1/4 HI-COLLAR LCKWSHR	4.000 EA
HW1001A04	WASHER, #4 SPLT LK ZINC	2.000 EA
34CB4510	COVER- 34 TACH. ADAP(CLOWTDR10478 ORDER	1.000 EA
34GS5002	GASKET-COVER 34 TACH ADAPTER	1.000 EA
51XW0832A07	8-32 X .44, TAPTITE II, HEX WSHR SLTD SE	3.000 EA
WD4100A26	HEYCO UNIVERSAL BUSHING P/N 2089, MTG HO	1.000 EA
12XN0440A12	4-40X.750 SLOTTED HEX HD CAP ZN	2.000 EA
WD4100A17	PLUG STIMPSON D4036	1.000 EA
HW5100A03SP	WAVY WASHER (W1543-017)	1.000 EA
34EP3300A29	PU ENDPLATE, MACH	1.000 EA
51XN1032A20	10-32 X 1 1/4 HX WS SL SR	2.000 EA
BP5201A11SP	BRUSH HOLDER ASSY W/BP4511A01 & BP3000A0	1.000 EA
80XN1032A03	10-32 X 3/16 SET SCREW	2.000 EA
34FN3002A01SP	EXTERNAL FAN, PLASTIC, .637/.639 HUB W/	1.000 EA
34FH4002A01	IEC FH NO GREASER	1.000 EA

Parts List (continued)		
Part Number	Description	Quantity
51XW1032A06	10-32 X .38, TAPTITE II, HEX WSHR SLTD S	3.000 EA
34CB4504SP	CONDUIT BOX LID, STAMPED	1.000 EA
34GS1011SP	GASKET, CONDUIT BOX LID	1.000 EA
51XW0832A07	8-32 X .44, TAPTITE II, HEX WSHR SLTD SE	2.000 EA
HW2501D13SP	KEY, 3/16 SQ X 1.375	1.000 EA
HA7000A04	KEY RETAINER 0.625 DIA SHAFTS	1.000 EA
X3B003Z029	TACH TG-300 50V .625BORE W/NOTCH CW	1.000 EA
18XN0632A16	FLAT HEAD SCREW	2.000 EA
WD4102A01	SR-6L-1 HEYCO STRN RELIEF OR 23MPO6L10 M	1.000 EA
MG1000G27	PAINT- S9282E CHARCOAL GREY	0.014 GA
MJ5004A05	#242-21 LOCTITE GENERAL PURPOSE MED. STR	0.001 EA
10XF0440S02	04-40 X 1/8 TYPE F HEX HD STAINLESS STIC	2.000 EA
HA6345A02	SHAFT ADAPTER,34 & 35 MTRTG200 & TG300 T	1.000 EA
HW1005W01	IOCKWASHER, 201 BEARING MO	1.000 EA
ML1424B14	UL3321,150C,14 GA,BLACK, #A1	8.500 IN
ML1425B14	UL3321,150C,14 GA,BLACK, #A2	8.500 IN
HA3100A37	THRUBOLT 10-32 X 8.500	4.000 EA
LB1119	WARNING LABEL	1.000 EA
LB1125C01	STD (STOCK) CARTON LABEL BALDOR WITH FLA	1.000 EA
LC0194	CONNECTION LABEL FOR TYPE PM-DC MOTOR W/	1.000 EA
LB5040	INSTRUCTION TAG, AC & DC	1.000 EA
NP0891L	NP STD LASER ENGRAVED DC MTRS, UL CSA CE	1.000 EA
35PA1007	PACKAGING GROUP	1.000 EA

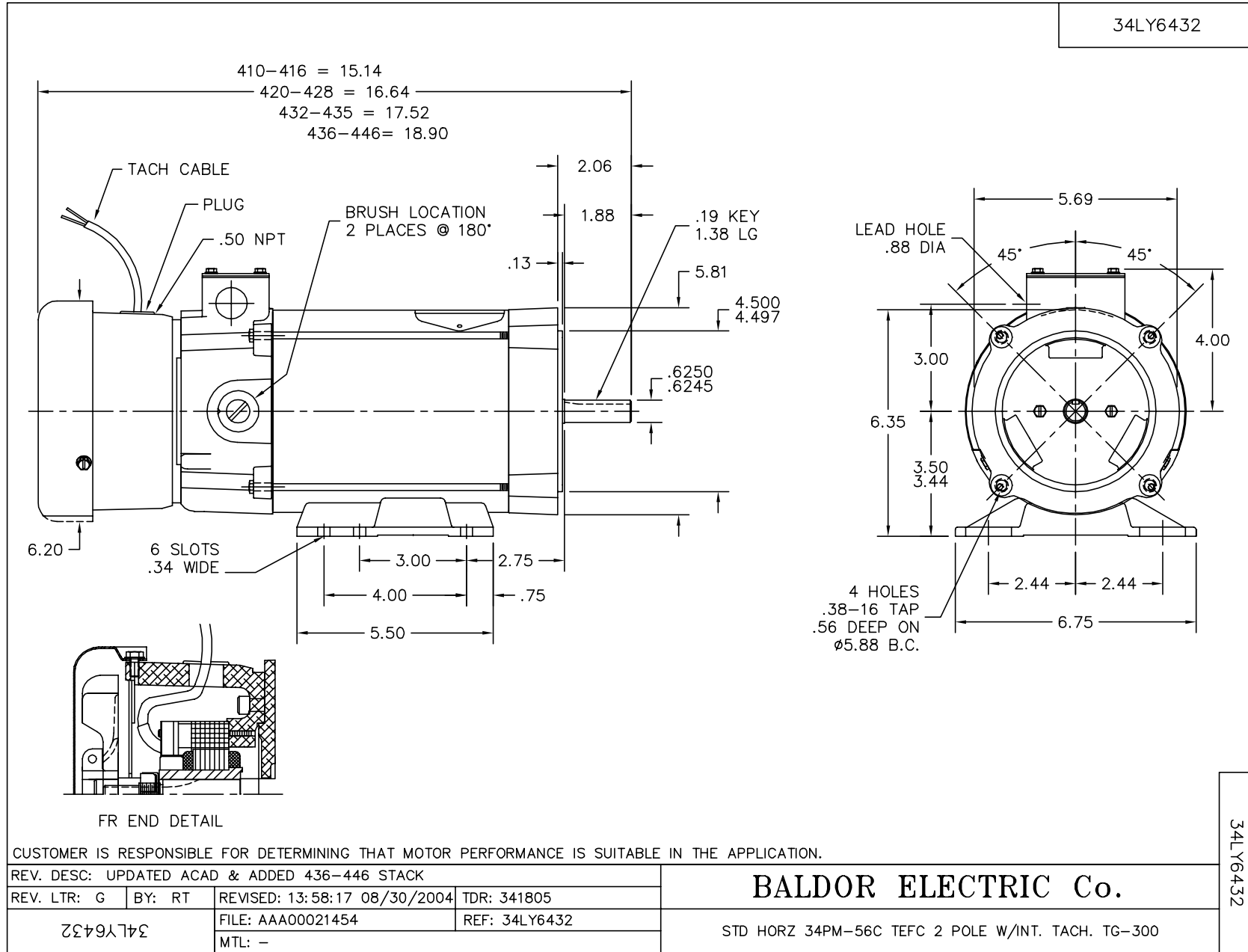

CD0194

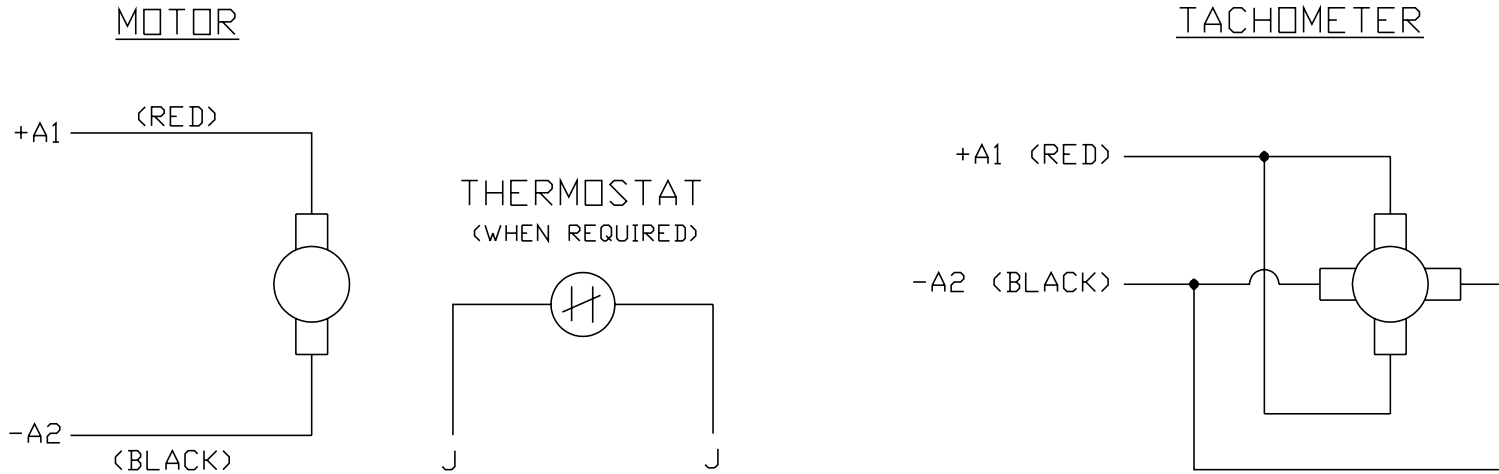

NOTES:

1. CCW ROTATION AS SHOWN FACING COMMUTATOR END. TO REVERSE MOTOR ROTATION OR TACHOMETER OUTPUT POLARITY INTERCHANGE LEADS A1(RED) & A2(BLACK)
2. LEAD COLORS FOR REFERENCE ONLY & NOT SPECIFIED BY THIS DRAWING. LEAD COLORS SPECIFIED BY LAYOUT DRAWING & BILL OF MATERIAL ONLY.

MATL: -			
REV: E	ADDED NOTE "LEAD COLORS FOR REFERENCE ONLY &..."		
761000	SCALE: -	BY: CK	REVISED: 07/28/95
	FILE: AAA00004503	TDR: 0078737	

BALDOR ELECTRIC Co.

CD TYPE P DC PERMANENT MAGNET MOTORS AND TACHOMETERS

CD0194