

BALDOR® • **RELIANCE**

Product Information Packet

CDPX3555

1HP,1750RPM,DC,56C,X3536P,XPFC,F1

Copyright © All product information within this document is subject to Baldor Electric Company copyright © protection, unless otherwise noted.

Part Detail							
Revision:	N	Status:	PRD/A	Change #:		Proprietary:	No
Type:	DC	Prod. Type:		Elec. Spec:	35WGZ164	CD Diagram:	
Enclosure:	XPFC	Mfg Plant:		Mech. Spec:	35P565	Layout:	
Frame:	56C	Mounting:	F1	Poles:	///	Created Date:	
Base:	RG	Rotation:	R	Insulation:	F	Eff. Date:	11-01-2012
Field Type:		Literature:		Elec. Diagram:		Replaced By:	

Nameplate NP0727XPSL

NO.			
SER.			
SPEC.	35P565Z164G1		
CAT.NO.	CDPX3555	T. CODE	T3C
HP	1	ENCL	XPFC
RPM	1750		
FRAME	56C	TYPE	3536P
ARM V	180	ARM A	4.9
FLD V		FLD A	
INSUL	F	AMB.	40
DUTY	CONT	SUPPLY	K
BRG/DE	6205	BRG/ODE	6203
BRUSHES	2/BP5035AB01		
BLANK			

Parts List		
Part Number	Description	Quantity
SA005562	SA 35P565Z164G1	1.000 EA
AA003211	AA 35P565Z164G1	1.000 EA
HW4002A02	1-11.5X2LG PIPE NIPPLE (F/S)	1.000 EA
11XW1032G06	10-32 X .38, TAPTITE II, HEX WSHR SLTD U	1.000 EA
HW3001B01	003SS CUP WASHER, FOR #8 SCREW	1.000 EA
HW1003A10	WASHER, #10 EX TH LK, ZN X	1.000 EA
35EP2700A01	FR EP-203 BRG- X35L-M	1.000 EA
HW4030A01	1-1/2" N.P.T. PIPE PLUG W/SQ.HEAD	2.000 EA
51XW0832A07	8-32 X .44, TAPTITE II, HEX WSHR SLTD SE	4.000 EA
HW5100A03SP	WAVY WASHER (W1543-017)	1.000 EA
35EP3702A06	PU EP-205 BRG-35X-56C-143-5TC	1.000 EA
51XN1032A20	10-32 X 1 1/4 HX WS SL SR	2.000 EA
HA3013A01	1/2-20X5/8 SPL.HX BOLT	2.000 EA
HW3021C06	3/32 DI X .625 PIN (F/S)	2.000 EA
XY3118A12	5/16-18 HEX NUT DIRECTIONAL SERRATION	4.000 EA
35FN3002A05SP	EXFN, PLASTIC, 6.376 OD, .638 ID	1.000 EA
51XB1214A16	12-14X1.00 HXWSSLD SERTYB	1.000 EA
51XW1032A06	10-32 X .38, TAPTITE II, HEX WSHR SLTD S	3.000 EA
35CB3500A01SP	CONDUIT BOX LID, MACH	1.000 EA
51XN2520A16	SCREW, HEX WS SLT, ZN, 1/4-20 X 1.00	4.000 EA
HW2501D13SP	KEY, 3/16 SQ X 1.375	1.000 EA
HA7000A04	KEY RETAINER 0.625 DIA SHAFTS	1.000 EA
NP0018	NP- XP CONDUIT BOX DO NOT MAKE SELLABLE	1.000 EA
NP0731	NAMEPLATE, CAUTION FOR DC EXPLOSION PROO	1.000 EA

Parts List (continued)		
Part Number	Description	Quantity
35RK5001	ROCKERARM ASSY X35PM W/TP1515A01 T'STAT	1.000 EA
35FH4005A01SP	IEC FH NO GREASER W/AUTOPHORETIC PRIMER	1.000 EA
MG1025G29	PAINT 789.205 DARK GRAY METALLIC (USE W/	0.014 GA
85XU0407A04	#4-7 X 1/4 DRIVE PIN	8.000 EA
BP5035AB01	BRUSH ASSY, GRADE AB	2.000 EA
BP5034	BRSH SPRG ASSY. "REV.B" 35X PM MTR(VULCA	2.000 EA
MJ5000A01	SEALANT, CHICO A COMPOUND	0.005 LB
35CB3001A02SP	EXPL PROOF CONDUIT BOX, 3/4"PIPE TAP LEA	1.000 EA
HA3104A11	THRUBOLT-5/16-18X10.50 F X	4.000 EA
LB5040	INSTRUCTION TAG, AC & DC	1.000 EA
LB1119	WARNING LABEL	1.000 EA
LB1125C01	STD (STOCK) CARTON LABEL BALDOR WITH FLA	1.000 EA
LB1161	LABEL,THERMOSTAT (ROLL LABEL)	1.000 EA
LC0194	CONNECTION LABEL FOR TYPE PM-DC MOTOR W/	1.000 EA
NP0727XPSL	SS XP DC UL CSA CC CL-I GP-D CL-II GP-F&	1.000 EA
G7PA1014	PACKAGING GROUP	1.000 EA

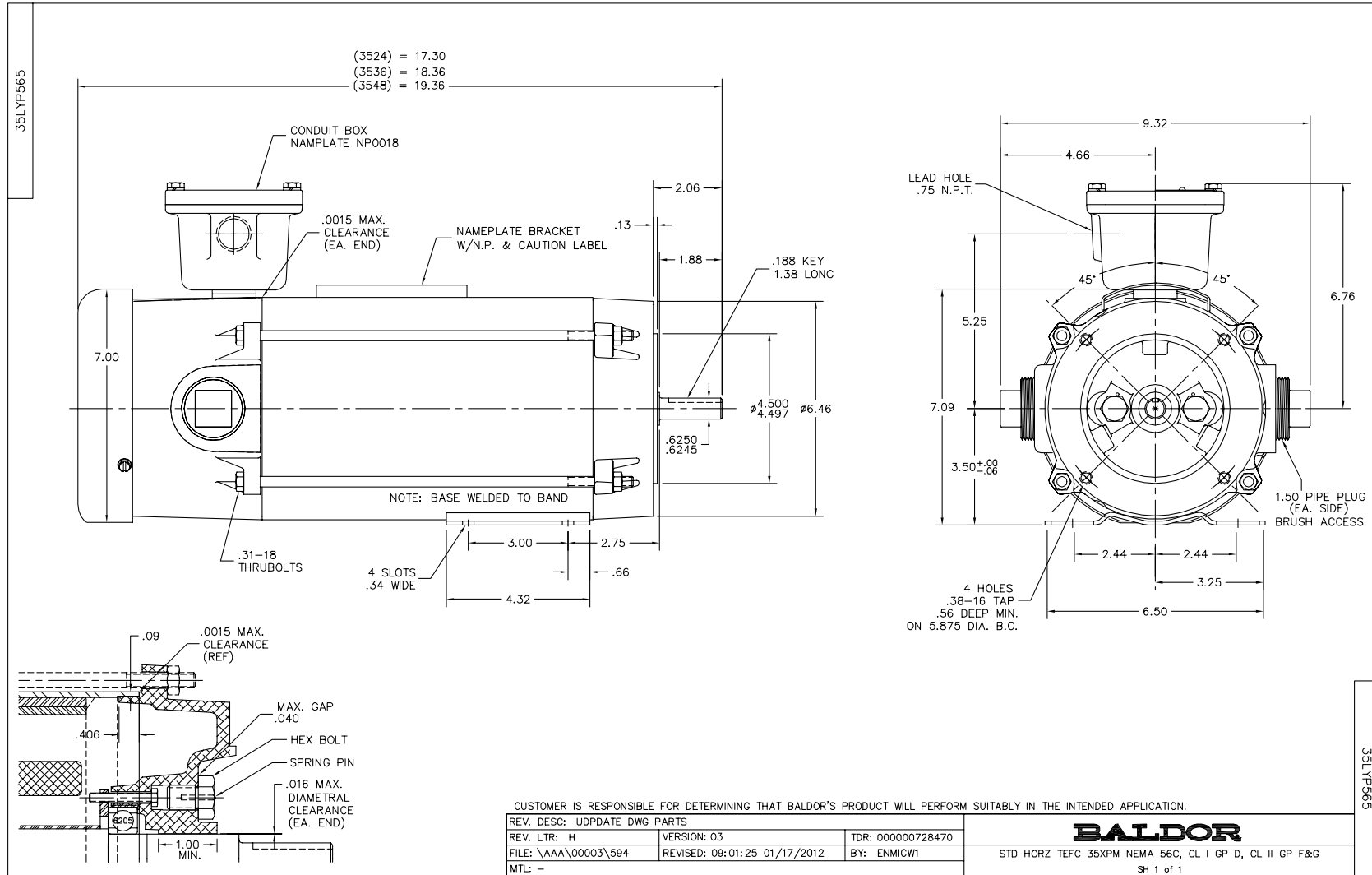

CD0194

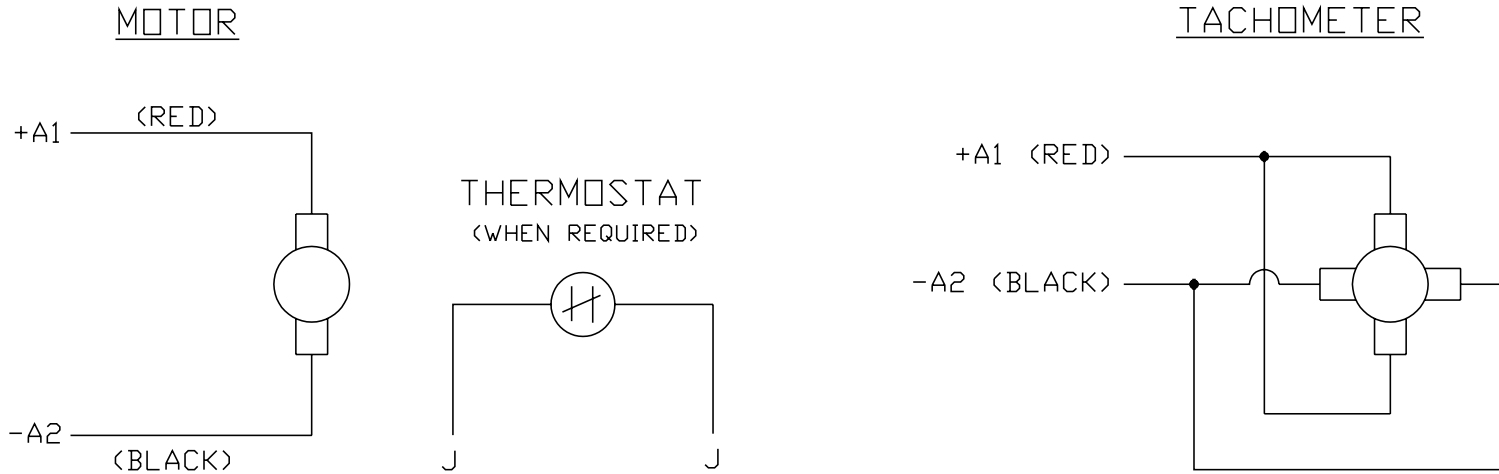

NOTES:

1. CCW ROTATION AS SHOWN FACING COMMUTATOR END. TO REVERSE MOTOR ROTATION OR TACHOMETER OUTPUT POLARITY INTERCHANGE LEADS A1(RED) & A2(BLACK)
2. LEAD COLORS FOR REFERENCE ONLY & NOT SPECIFIED BY THIS DRAWING. LEAD COLORS SPECIFIED BY LAYOUT DRAWING & BILL OF MATERIAL ONLY.

MATL: -			
REV: E	ADDED NOTE "LEAD COLORS FOR REFERENCE ONLY &..."		
761000	SCALE: -	BY: CK	REVISED: 07/28/95
	FILE: AAA00004503		TDR: 0078737

BALDOR ELECTRIC Co.

CD TYPE P DC PERMANENT MAGNET MOTORS AND TACHOMETERS

CD0194