

# **BALDOR**® • ***RELIANCE***

## **Product Information Packet**

# **CECP3587T**

**2HP,1755RPM,3PH,60HZ,145TC,0535M,TEFC,F1**

Copyright © All product information within this document is subject to Baldor Electric Company copyright © protection, unless otherwise noted.

Part Detail									
Revision:	E	Status:	PRD/A	Change #:		Proprietary:	No		
Type:	AC	Prod. Type:	0535M	Elec. Spec:	05WGX009	CD Diagram:			
Enclosure:	TEFC	Mfg Plant:		Mech. Spec:	05F007	Layout:			
Frame:	145TC	Mounting:	F1	Poles:	04	Created Date:	12-29-2008		
Base:	RG	Rotation:	R	Insulation:	F	Eff. Date:	08-20-2011		
Leads:	9#18	Literature:		Elec. Diagram:		Replaced By:			
Nameplate NP2069E									
CAT.NO.	CECP3587T								
SPEC.	05F007X009G1								
HP	2								
VOLTS	208-230/460								
AMP	6.1-5.6/2.8								
RPM	1755								
FRAME	145TC	HZ			60	PH	3		
SER.F.	1.15	CODE			L	DES	B	CL	F
NEMA-NOM-EFF	88.5	PF			75				
RATING	40C AMB-CONT								
CC	010A	USABLE AT 208V							
DE	6205	ODE			6205				
ENCL	TEFC	SN							

Parts List		
Part Number	Description	Quantity
SA178736	SA 05F007X009G1	1.000 EA
RA166809	RA 05F007X009G1	1.000 EA
34FN3002B01	EXTERNAL FAN, PLASTIC, .637/.639 HUB W/	1.000 EA
S/P107-000-001	SUPER E PROC'S-FS & WS PLTS-POLYREX EM G	1.000 EA
HW3201A05	3/8-16 EYEBOLT	1.000 EA
06CB1000A02G	CONDUIT BOX, MACH GRAY	1.000 EA
RM1016	LEAD SEPARATOR GASKET - 305/306 C.P.MOTO	1.000 EA
51XW2520A12	.25-20 X .75, TAPTITE II, HEX WSHR SLTD	2.000 EA
11XW1032G06	10-32 X .38, TAPTITE II, HEX WSHR SLTD U	1.000 EA
HW3001B01	003SS CUP WASHER, FOR #8 SCREW	1.000 EA
10XN2520S06	1/4 20X3/8 HX HD CAP S.S.	2.000 EA
WD1000B16	KPA-4C BURNDY TERMINAL	2.000 EA
35EP1102B03G	FREP TEFC 205 BRG,GRSR,RLF,.125 NPT DRAI	1.000 EA
HW4500A19	1/4-28X1/4 SLOTTED PLUG F/S	1.000 EA
HW4500A17	317400 ALEMITE GREASE RELIEF	1.000 EA
HA4001A01SP	DRAIN PLUG, PLASTIC (MICRO PLAS)	1.000 EA
HW5100A05	WVY WSHR F/205 & 304 BRGS	1.000 EA
35EP1329A16G	PUEP ENCL 143-5TC 205 BRG,GRSR,RLF,NPT D	1.000 EA
HW4500A19	1/4-28X1/4 SLOTTED PLUG F/S	1.000 EA
HW4500A17	317400 ALEMITE GREASE RELIEF	1.000 EA
HA4001A01SP	DRAIN PLUG, PLASTIC (MICRO PLAS)	1.000 EA
51XN1032A20	10-32 X 1 1/4 HX WS SL SR	2.000 EA
HA3100A28	THRUBOLT 10-32 X 8.187	4.000 EA
51XB1214A16	12-14X1.00 HXWSSLD SERTYB	1.000 EA

Parts List (continued)		
Part Number	Description	Quantity
35FH1000A01G	35FH1000A01 W/GRAY FLUIDIZ	1.000 EA
10XN2520A16	1/4-20 X 1 HEX HEAD CAP SCR, ZINC PLATED	3.000 EA
HW1001A25	LOCKWASHER 1/4, ZINC PLT .493 OD, .255 I	3.000 EA
WD4100A03	DE-750 HEYCO PLUG 62MP0750 MICRO PLASTIC	1.000 EA
06CB1502A01G	LIPPED CONDUIT BOX LID, MACH GRAY EPOXY	1.000 EA
06GS1003	GASKET, KOBX LID, 1/8" THICK BLACK NEOPR	1.000 EA
10XN2520A12	O1/4-20X 3/4 HEX HEAD CAP	2.000 EA
HW1001A25	LOCKWASHER 1/4, ZINC PLT .493 OD, .255 I	2.000 EA
HW4600B32SP	V-RING SLINGER 1.000 X 1.540 X 0.240	1.000 EA
HA1005A03SP	SLINGER, OD 1.750, ID .938, 205 BRG	1.000 EA
HW2501D13SP	KEY, 3/16 SQ X 1.375	1.000 EA
HA7000A01	KEY RETAINER 7/8" DIA SHAFT	1.000 EA
MJ5001A01	46-665 RED SEALER	0.001 QT
85XU0407S04	4X1/4 U DRIVE PIN STAINLESS	2.000 EA
LB1115	LABEL,LIFTING DEVICE	1.000 EA
LB1002	LABEL,MARINE DUTY (ON ROLLS)	1.000 EA
MJ1000A75	GREASE, POLYREX EM EXXON	0.050 LB
MG1025N19	PAINT, 778.50 WILKO, RELIANCE ELEC GREEN	0.022 GA
LB1125C02	SUPER-E (STOCK CTN LABEL SUPER-E WITH FL	1.000 EA
LC0005E01	CONN.DIA./WARNING LABEL (LC0005/LB1119)	1.000 EA
LB1357	ENERGY GUIDE LABEL (BOX LABEL)	1.000 SH
NP2069E	SS CP SUPER-E UL CSA-EEV CC REV MTG	1.000 EA
36PA1000	PACK GROUP W/LB5001	1.000 EA

**Performance Data at 460V, 60Hz, 2.0HP (Typical performance - Not guaranteed values)**

General Characteristics			
Full Load Torque:	6.01 LB-FT	Start Configuration:	DOL
No-Load Current:	1.64 Amps	Break-Down Torque:	26.6 LB-FT
Line-line Res. @ 25°C.:	6.46 Ohms A Ph / 0.0 Ohms B Ph	Pull-Up Torque:	20.5 LB-FT
Temp. Rise @ Rated Load:	38 C	Locked-Rotor Torque:	21.6 LB-FT
Temp. Rise @ S.F. Load:	47 C	Starting Current:	25.0 Amps

Load Characteristics							
% of Rated Load	25	50	75	100	125	150	S.F.
Power Factor:	34.0	54.0	67.0	75.0	80.0	83.0	78.0
Efficiency:	80.0	86.9	88.5	88.6	87.9	86.8	88.2
Speed:	1790.0	1779.0	1768.0	1756.0	1743.0	1729.0	1748.0
Line Amperes:	1.74	2.01	2.39	2.83	3.34	3.88	3.14

Performance Graph at 460V, 60Hz, 2.0HP Typical performance - Not guaranteed values

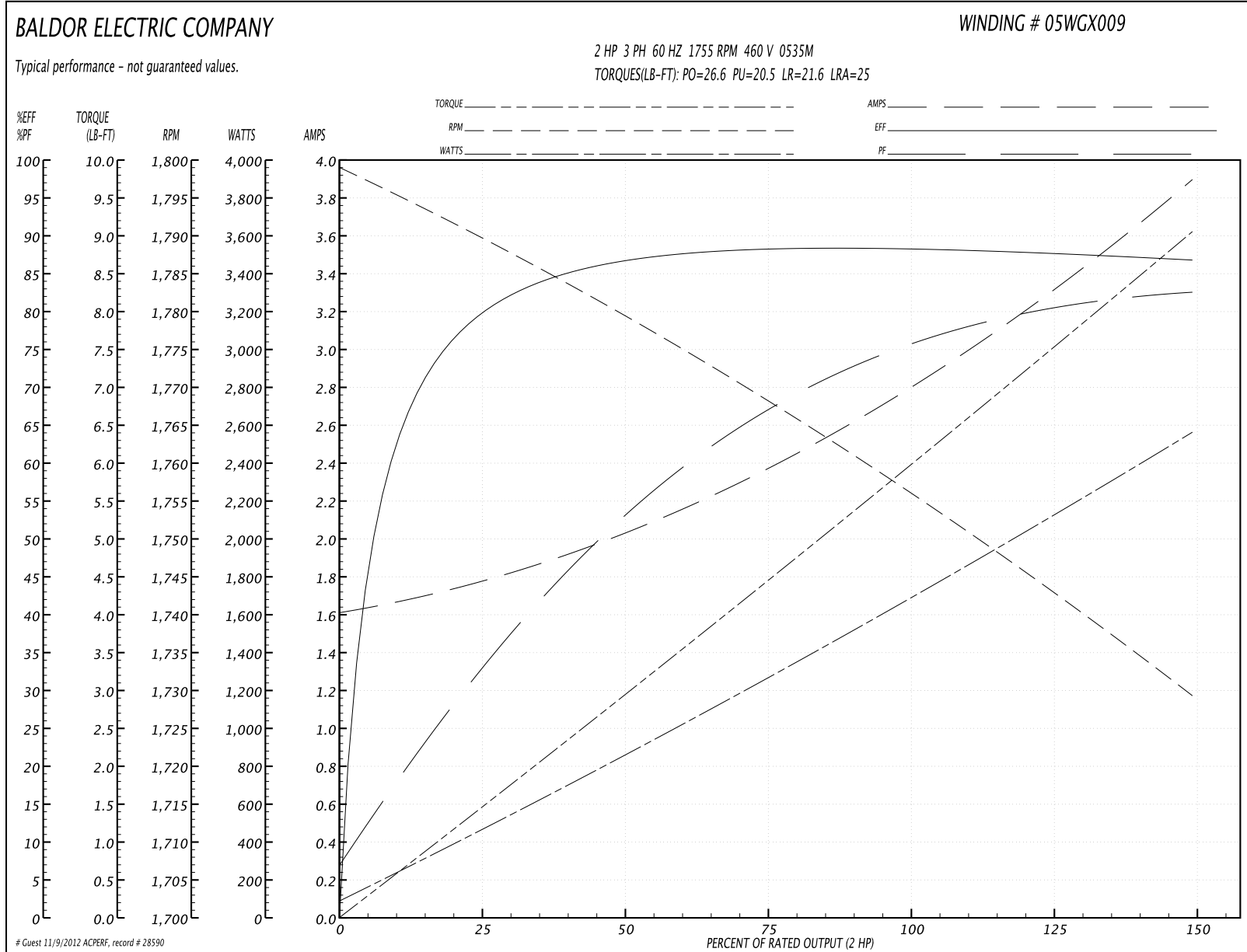

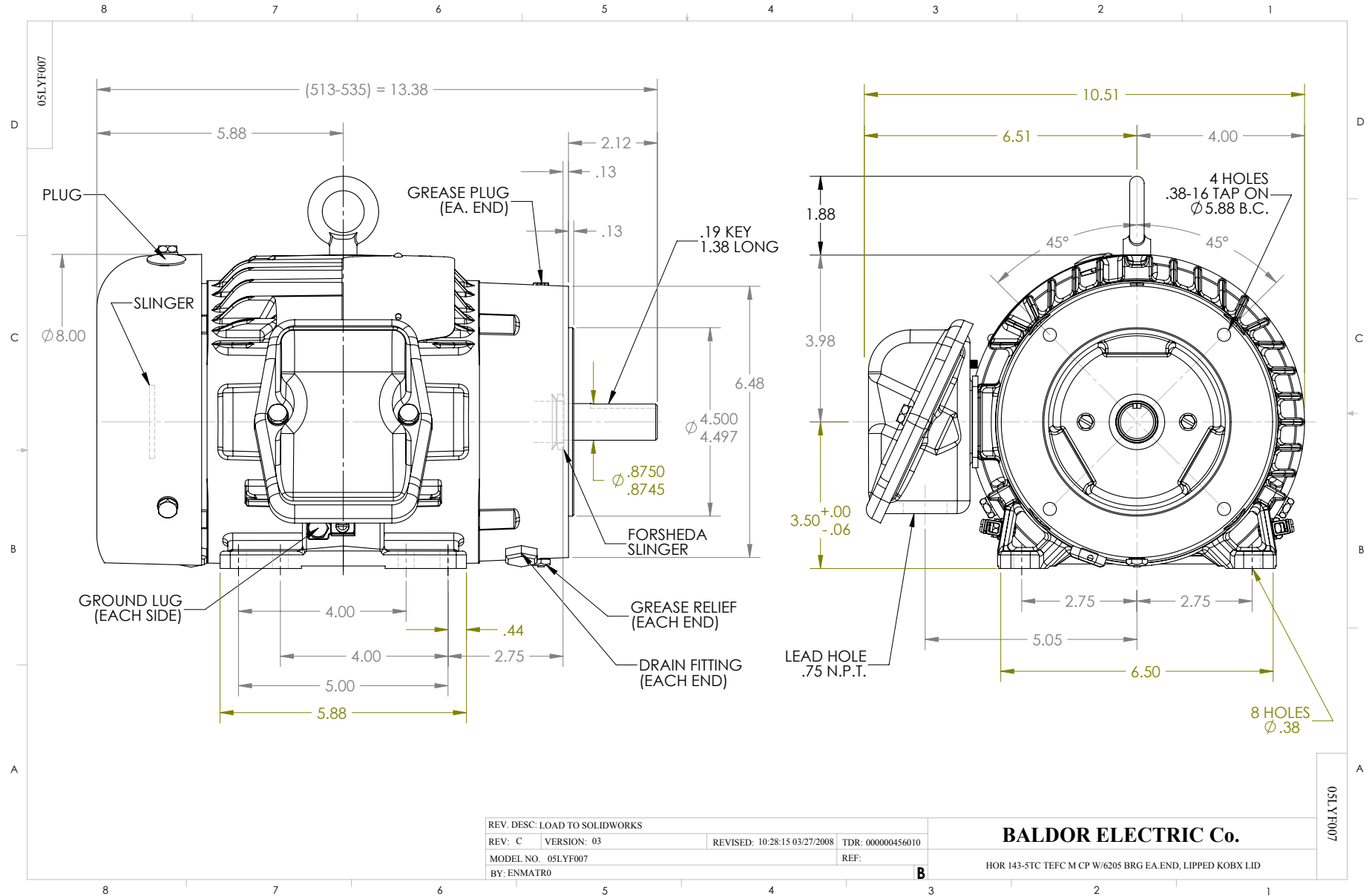

CD0005

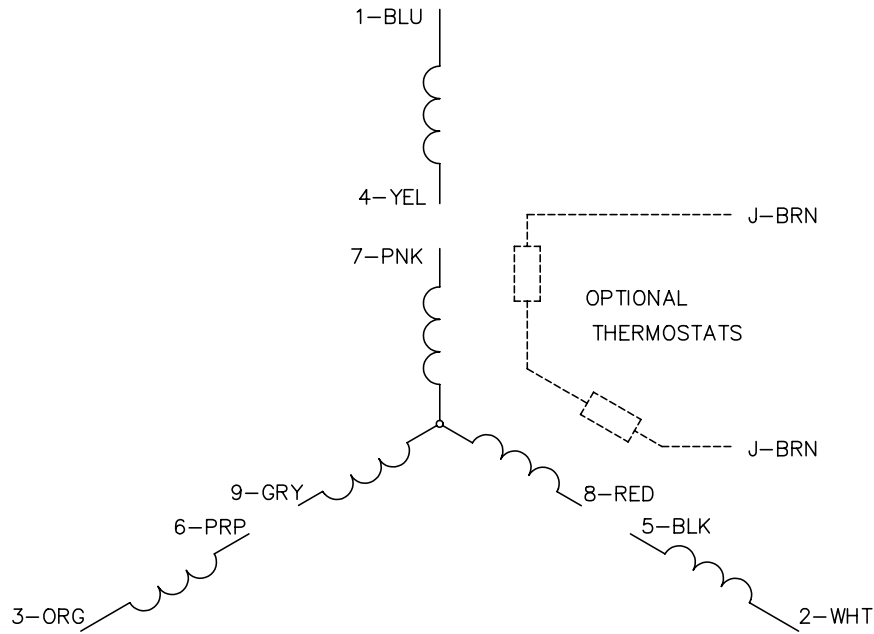

LOW VOLTAGE  
(2Y)



LINE

HIGH VOLTAGE  
(1Y)

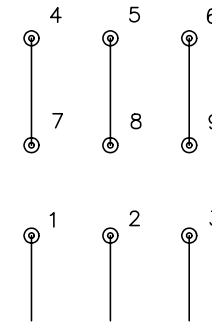

LINE

NOTES:

1. INTERCHANGE ANY TWO LINE LEADS TO REVERSE ROTATION.
2. OPTIONAL THERMOSTATS ARE PROVIDED WHEN SPECIFIED.
3. ACTUAL NUMBER OF INTERNAL PARALLEL CIRCUITS MAY BE A MULTIPLE OF THOSE SHOWN ABOVE.
4. LEAD COLORS ARE OPTIONAL. LEADS MUST ALWAYS BE NUMBERED AS SHOWN.

REV. DESC: REVISE TO SHOW OPTIONAL COLORS			
REV. LTR: E	BY: JLP	REVISED: 01/19/99 10:15	TDR: 0171435
90000		FILE: AAA00005140	MDL: -
		MTL: -	

**BALDOR ELECTRIC Co.**

3PH, DV, 9 LEADS

CD0005