

BALDOR® • RELIANCE

Product Information Packet

CECP4114T

50HP,3540RPM,3PH,60HZ,326TSC,1256M,TEFC

Copyright © All product information within this document is subject to Baldor Electric Company copyright © protection, unless otherwise noted.

Part Detail							
Revision:	B	Status:	PRD/A	Change #:		Proprietary:	No
Type:	AC	Prod. Type:	1256M	Elec. Spec:	12WGX911	CD Diagram:	
Enclosure:	TEFC	Mfg Plant:		Mech. Spec:	12F981	Layout:	
Frame:	326TSC	Mounting:	F1	Poles:	02	Created Date:	01-17-2011
Base:	RG	Rotation:	R	Insulation:	F	Eff. Date:	09-30-2011
Leads:	9#8	Literature:		Elec. Diagram:		Replaced By:	

Nameplate NP1260E							
CAT.NO.	CECP4114T						
SPEC.	12F981X911						
HP	50						
VOLTS	230/460						
AMP	112/56						
RPM	3540						
FRAME	326TSC	HZ	60	PH	3		
SER.F.	1.15	CODE	H	DES	B	CL	F
NEMA-NOM-EFF	94.1	PF	89				
RATING	40C AMB-CONT						
CC	010A	USABLE AT 208V	124				
DE	6312	ODE	6312				
ENCL	TEFC	SN					

Parts List		
Part Number	Description	Quantity
SA215251	SA 12F981X911	1.000 EA
RA202446	RA 12F981X911	1.000 EA
37FN3002C04	EXFN, PLASTIC, 6.00 OD, 2.000 ID	1.000 EA
S/P107-000-004	SUPER-E(284 FR. & UP)-CL PLANT,POLYREX E	1.000 EA
10CB1000A04P	CONDUIT BOX, MACH W/EPOXY PRIMER	1.000 EA
09GS1010	GASKET, DWG, LEADWIRE SEPERATOR	1.000 EA
10XN3118K16	5/16-18 X 1" GRADE #5, STL, ZINC PLATE	4.000 EA
HW1001A31	LOCKWASHER 5/16, ZINC PLT.591 OD, .319 I	4.000 EA
WD1000B16	KPA-4C BURNDY TERMINAL	1.000 EA
10XN2520K08	1/4-20 X .50 GRADE #5, STL, ZINC PLATE	1.000 EA
HW1001A25	LOCKWASHER 1/4, ZINC PLT .493 OD, .255 I	1.000 EA
HA4017A10	1/8X1.25 GREASE EXT (F/S)	1.000 EA
HA4024A02	1/8 DOUBLE FEMALE SS CPLG, MCM #4464K351	1.000 EA
HA4017A01	1/8 X 4 GREASE EXT (F/S)	1.000 EA
HA3400A13SP	STUD, 1/2-13 X 7" WELKER	4.000 EA
HW1001A50	LOCKWASHER 1/2, ZINC PLT,.879 OD, .509 I	3.000 EA
HA1005A04SP	SLINGER, OD 3.620, ID 1.98,	1.000 EA
HW5100A15	W4997-050 WVY WSHR (WB)	1.000 EA
HW4500A20	1/8NPT SL PIPE PLUG	1.000 EA
10XN3118K40	5/16-18 X 2.50" HEX HD, GRADE 5	2.000 EA
12EP1105A97P	PU EP, MACH, PLS W/EPOXY PRIMER	1.000 EA
10XN5013K28	1/2-13 X 1.75 HEX HEAD MACH SCREW,GRAD	4.000 EA
HW1001A50	LOCKWASHER 1/2, ZINC PLT,.879 OD, .509 I	4.000 EA
HW4500A20	1/8NPT SL PIPE PLUG	1.000 EA

Parts List (continued)		
Part Number	Description	Quantity
HW4600B41	V-RING SLINGER 2.125 X 2.880 X 0.280	1.000 EA
10XN3118K44	5/16-18 X 2.75" HEX HD, GRADE 5	4.000 EA
12FH1002A33P	FAN COVER, MACH ,EPOXY PRIMER	1.000 EA
HW1001A50	LOCKWASHER 1/2, ZINC PLT ,.879 OD, .509 I	4.000 EA
XY5013A12	NUT, 1/2-13,HEX,STEEL,ZINCPLATED	4.000 EA
10CB1503A01P	CONDUIT BOX LIPPED LID, MACH W/EPXY PRMR	1.000 EA
14GS1003	GASKET CONDUIT BOX LID, NEOP	1.000 EA
10XN2520K16	1/4-20 X 1" HX HD SCRW GRADE 5, ZINC P	4.000 EA
HW1001A25	LOCKWASHER 1/4, ZINC PLT .493 OD, .255 I	4.000 EA
HW2501H18	KEY, 1/2 SQ X 2.000	1.000 EA
MJ5001A01	46-665 RED SEALER	0.031 QT
MJ5001A14	DYNAPRO SEAL, CP MOTORS VC#2508050 (603	0.030 EA
LB1115	LABEL,LIFTING DEVICE	1.000 EA
LB1002	LABEL,MARINE DUTY (ON ROLLS)	1.000 EA
LB5040	INSTRUCTION TAG, AC & DC	1.000 EA
12EP1111A35GP6	FR ENDPLATE, MACH W/EPOXY PRIMER & RELIA	1.000 EA
HW4500A17	317400 ALEMITE GREASE RELIEF	1.000 EA
HW4500A21	1618BALEMITE FITTING 825 UNIVERSAL	1.000 EA
HA4051A00	PLASTIC CAP FOR GREASE FITTING	1.000 EA
HA4001A01SP	DRAIN PLUG, PLASTIC (MICRO PLAS)	1.000 EA
MJ1000A75	GREASE, POLYREX EM EXXON	0.200 LB
HW4500A17	317400 ALEMITE GREASE RELIEF	1.000 EA
HW4500A03	GREASE FITTING, .125 NPT 1610(ALEMITE) 8	1.000 EA
HA4051A00	PLASTIC CAP FOR GREASE FITTING	1.000 EA

Parts List (continued)		
Part Number	Description	Quantity
HA4001A01SP	DRAIN PLUG, PLASTIC (MICRO PLAS)	1.000 EA
HW2500A25	WOODRUFF KEY USA #1008 #BLOW CARBON STEE	1.000 EA
51XB1214A20	12-14X1.25 HXWSSLD SERTYB	1.000 EA
MG1025N19	PAINT, 778.50 WILKO, RELIANCE ELEC GREEN	0.080 GA
85XU0407S04	4X1/4 U DRIVE PIN STAINLESS	2.000 EA
LB1119	WARNING LABEL	1.000 EA
LB1125C02	SUPER-E (STOCK CTN LABEL SUPER-E WITH FL	4.000 EA
LB1357	ENERGY GUIDE LABEL (BOX LABEL)	1.000 SH
LC0181	CONNECTION LABEL	1.000 EA
NP1260E	SS CP SUPER-E UL CSA CC	1.000 EA
12PA1000	PACKAGING GROUP COMBINED PRINT PK1024A06	1.000 EA

Performance Data at 460V, 60Hz, 50.0HP (Typical performance - Not guaranteed values)

General Characteristics			
Full Load Torque:	74.1 LB-FT	Start Configuration:	DOL
No-Load Current:	16.6 Amps	Break-Down Torque:	292.0 LB-FT
Line-line Res. @ 25°C.:	0.099999 Ohms A Ph / 0.0 Ohms B Ph	Pull-Up Torque:	97.3 LB-FT
Temp. Rise @ Rated Load:	78 C	Locked-Rotor Torque:	134.0 LB-FT
Temp. Rise @ S.F. Load:	95 C	Starting Current:	403.0 Amps

Load Characteristics							
% of Rated Load	25	50	75	100	125	150	S.F.
Power Factor:	60.0	80.0	87.0	89.0	90.0	91.0	90.0
Efficiency:	90.8	94.0	94.5	94.3	93.8	93.2	94.0
Speed:	3584.7	3573.5	3562.3	3550.1	3538.9	3526.5	3543.0
Line Amperes:	21.6	31.3	42.9	55.7	69.3	82.9	63.9

Performance Graph at 460V, 60Hz, 50.0HP Typical performance - Not guaranteed values

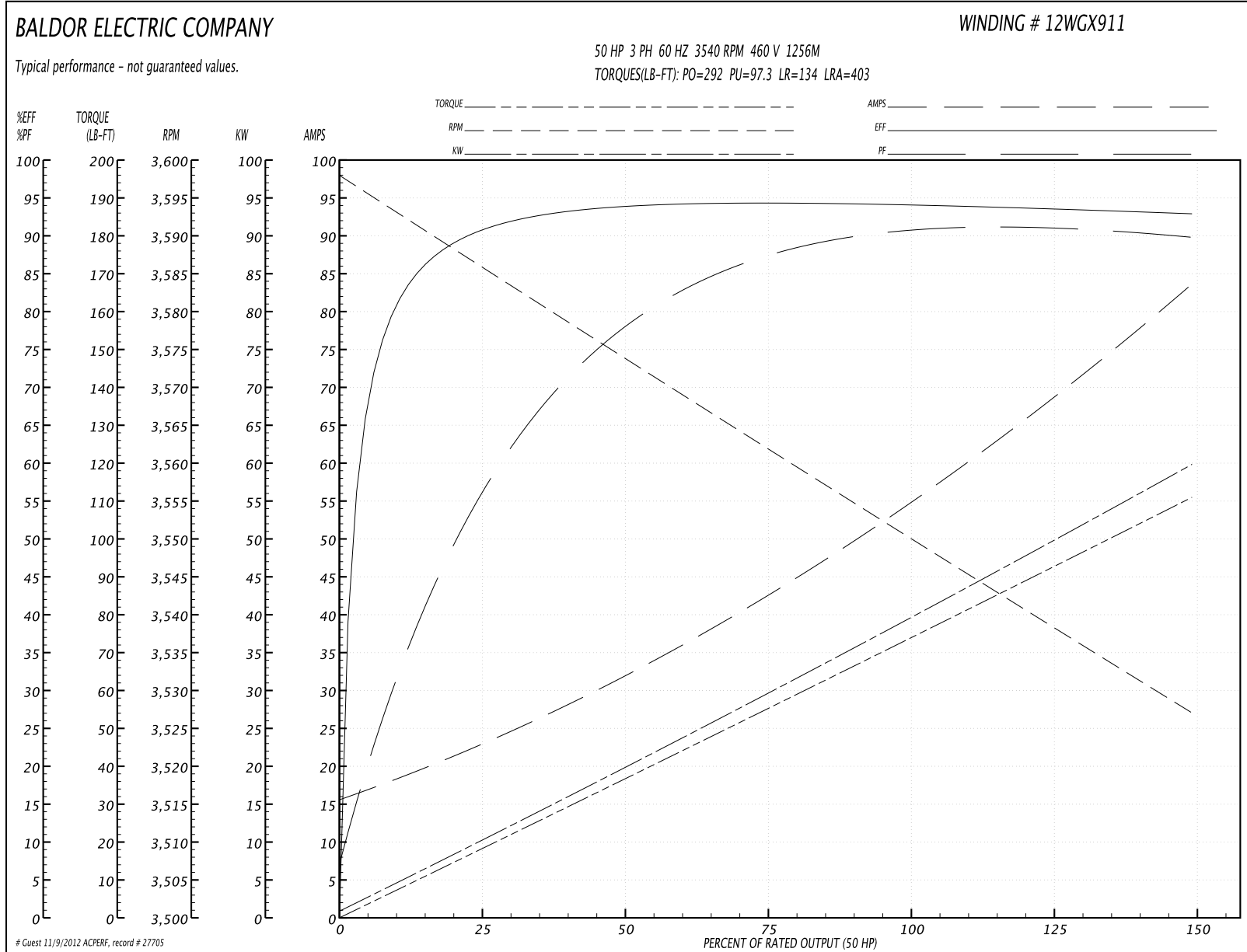

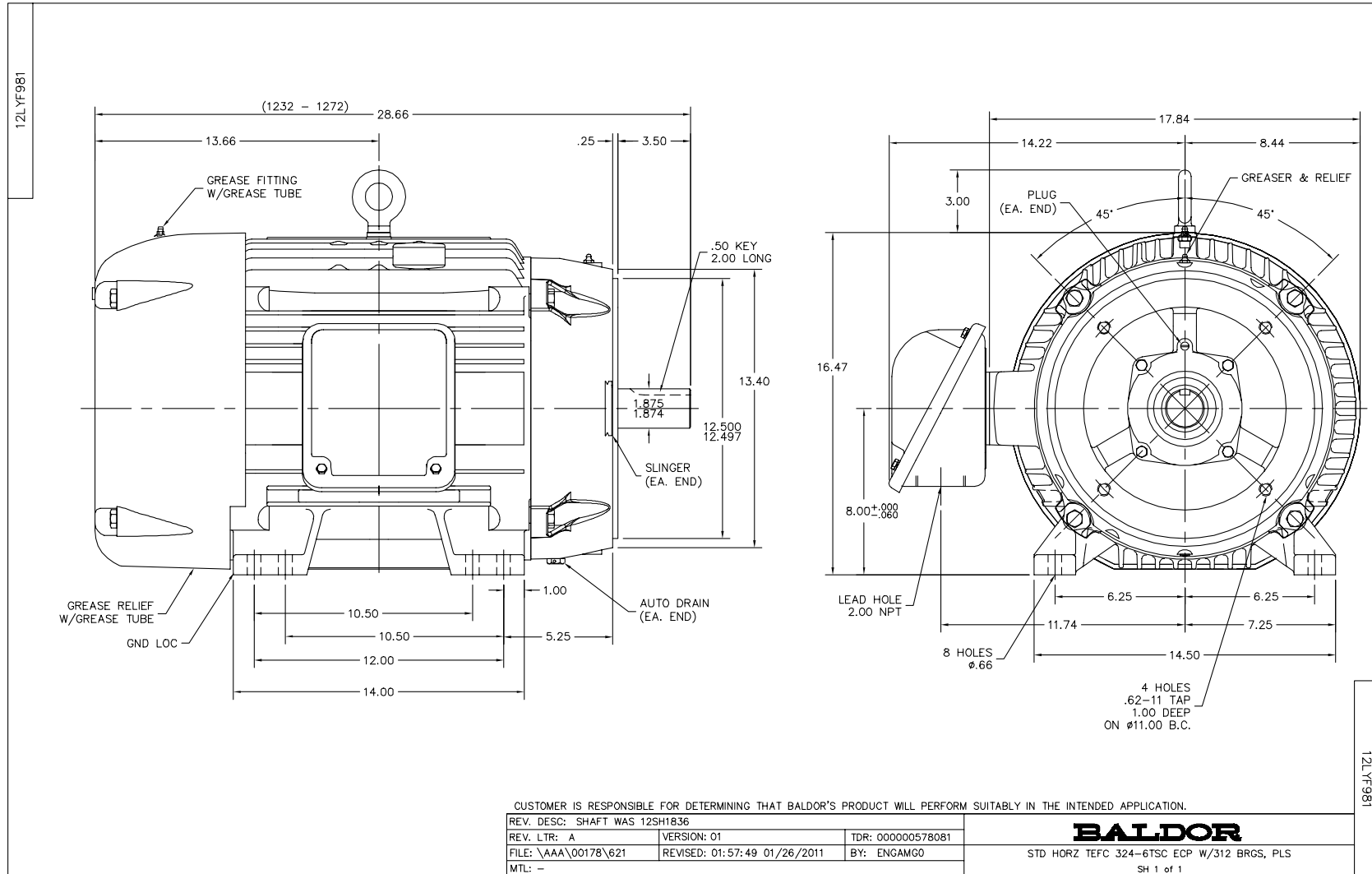

CD0180

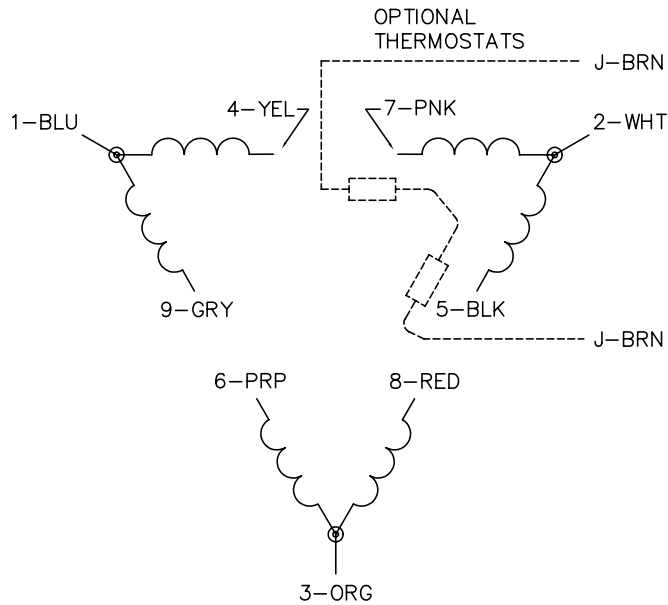

LOW VOLTAGE
(2D)

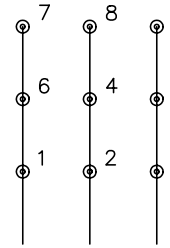

LINE

HIGH VOLTAGE
(1D)

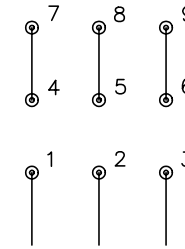

LINE

NOTES:

1. INTERCHANGE ANY TWO LINE LEADS TO REVERSE ROTATION.
2. OPTIONAL THERMOSTATS ARE PROVIDED WHEN SPECIFIED.
3. ACTUAL NUMBER OF INTERNAL PARALLEL CIRCUITS MAY BE A MULTIPLE OF THOSE SHOWN ABOVE.
4. LEAD COLORS ARE OPTIONAL. LEADS MUST ALWAYS BE NUMBERED AS SHOWN.

REV. DESC: REVISE TO SHOW OPTIONAL COLORS			
REV. LTR: C	BY: JLP	REVISED: 01/21/99 2:28	TDR: 0171435
0810D0		FILE: AAA00005148	MDL: -
		MTL: -	

BALDOR ELECTRIC Co.

3PH, DV, 9 LEADS, DELTA CONNECTION

CD0180