

# **BALDOR® • RELIANCE**

## **Product Information Packet**

# **CEM2543T**

**50HP, 1775RPM, 3PH, 60HZ, 326TC, 4256M, OPSB, F**

Copyright © All product information within this document is subject to Baldor Electric Company copyright © protection, unless otherwise noted.

Part Detail							
Revision:	D	Status:	PRD/A	Change #:		Proprietary:	No
Type:	AC	Prod. Type:	4256M	Elec. Spec:	42WGW387	CD Diagram:	
Enclosure:	OPSB	Mfg Plant:		Mech. Spec:	42D102	Layout:	
Frame:	326TC	Mounting:	F1	Poles:	04	Created Date:	08-03-2010
Base:	RG	Rotation:	R	Insulation:	F	Eff. Date:	01-03-2012
Leads:	9#8	Literature:		Elec. Diagram:		Replaced By:	

Nameplate NP2138L							
CAT.NO.	CEM2543T	P/N		ENCLOSURE	OPSB		
SPEC.	42D102W387G1	CC	010A	FRAME	326TC	S/N	
HP	50	CLASS	F	HZ	60		
RPM	1775	PH	3	DES	B		
VOLT	230/460	KVA-CODE	G	ODE BRG	6311	DE BRG	6312
AMP	114/57	USABLE AT 208V	121				
RATING	40C AMB-CONT	GREASE	POLYREX EM				
NEMA-NOM-EFF	94.5	PF	87	SER.F.	1.15		
HTR-VOLTS		HTR-AMPS		MAX. SPACE HEATER TEMP.			

Parts List		
Part Number	Description	Quantity
SA200900	SA 42D102W387G1	1.000 EA
RA188210	RA 42D102W387G1	1.000 EA
S/P107-000-004	SUPER-E(284 FR. & UP)-CL PLANT,POLYREX E	1.000 EA
HA6360	LIFTING LUG FOR 42 FRAME MOTORS.	2.000 EA
HA6017A01	CAST ADAPTOR	1.000 EA
19XW3118A12	.31-18 X .75 HEX WASHER HEAD TAPTITE II	2.000 EA
HW1001A31	LOCKWASHER 5/16, ZINC PLT.591 OD, .319 I	2.000 EA
10CB3001	CONDUIT BOX CAST W/2.500 LEAD HOLE	1.000 EA
19XW3118A12	.31-18 X .75 HEX WASHER HEAD TAPTITE II	4.000 EA
HW1001A31	LOCKWASHER 5/16, ZINC PLT.591 OD, .319 I	4.000 EA
WD1000B16	KPA-4C BURNDY TERMINAL	1.000 EA
51XF2520A08	SCREW, HEX SER SLT HD, ZN 1/4-20 X .50 L	1.000 EA
42EP3200A01	FR ENDPLATE, MACH 324-6T	1.000 EA
HA4051A00	PLASTIC CAP FOR GREASE FITTING	1.000 EA
HW5100A13	W4627-047 WVY WSHER	1.000 EA
42EP1300A20	PU ENDPLATE, MACH	1.000 EA
HA4051A00	PLASTIC CAP FOR GREASE FITTING	1.000 EA
10XN3118K40	5/16-18 X 2.50" HEX HD, GRADE 5	4.000 EA
HW1001A31	LOCKWASHER 5/16, ZINC PLT.591 OD, .319 I	4.000 EA
XY5013A12	NUT, 1/2-13,HEX,STEEL,ZINCPLATED	8.000 EA
10CB3500SP	CONDUIT BOX LID, CAST	1.000 EA
51XW2520A12	.25-20 X .75, TAPTITE II, HEX WSHR SLTD	4.000 EA
HW2501H33	KEY, 1/2 SQ X 3.875	1.000 EA
LB1115	LABEL,LIFTING DEVICE	1.000 EA

Parts List (continued)		
Part Number	Description	Quantity
HW4500A03	GREASE FITTING, .125 NPT 1610(ALEMITE) 8	1.000 EA
HW4500A20	1/8NPT SL PIPE PLUG	1.000 EA
MJ1000A75	GREASE, POLYREX EM EXXON	0.030 LB
HW4500A03	GREASE FITTING, .125 NPT 1610(ALEMITE) 8	1.000 EA
HW4500A20	1/8NPT SL PIPE PLUG	1.000 EA
MG1000Y03	WILKO 689.710 GOLD PAINT SUPER E	0.080 GA
85XU0407A04	#4-7 X 1/4 DRIVE PIN	4.000 EA
HA3151A03	THRUBOLT STUD 1/2-13 X 20.5	4.000 EA
42AD2001A01	BAFFLE PLATE 42 OPEN, SLOTTED BAND MTRS	1.000 EA
42AD2001A01	BAFFLE PLATE 42 OPEN, SLOTTED BAND MTRS	1.000 EA
LB1119	WARNING LABEL	1.000 EA
LB1125C02	SUPER-E (STOCK CTN LABEL SUPER-E WITH FL	4.000 EA
LB1357	ENERGY GUIDE LABEL (BOX LABEL)	1.000 SH
LC0181	CONNECTION LABEL	1.000 EA
NP2138L	ALUM SUPER-E UL CSA-EEV PREM CC (300	1.000 EA
40PA1000	PACKAGING GROUP	1.000 EA
LB5040	INSTRUCTION TAG, AC & DC	1.000 EA

**Performance Data at 460V, 60Hz, 50.0HP (Typical performance - Not guaranteed values)**

General Characteristics							
Full Load Torque:	148.0 LB-FT			Start Configuration:	DOL		
No-Load Current:	20.2 Amps			Break-Down Torque:	420.0 LB-FT		
Line-line Res. @ 25°C.:	0.1208 Ohms A Ph / 0.0 Ohms B Ph			Pull-Up Torque:	222.0 LB-FT		
Temp. Rise @ Rated Load:	36 C			Locked-Rotor Torque:	280.0 LB-FT		
Temp. Rise @ S.F. Load:	47 C			Starting Current:	378.0 Amps		
Load Characteristics							
% of Rated Load	25	50	75	100	125	150	S.F.
Power Factor:	53.0	75.0	84.0	87.0	88.0	88.0	87.0
Efficiency:	91.8	94.5	94.9	94.7	94.2	93.4	94.4
Speed:	1793.0	1787.0	1781.0	1775.0	1769.0	1762.0	1771.0
Line Amperes:	24.1	33.0	44.3	57.0	70.8	85.4	65.2

Performance Graph at 460V, 60Hz, 50.0HP Typical performance - Not guaranteed values

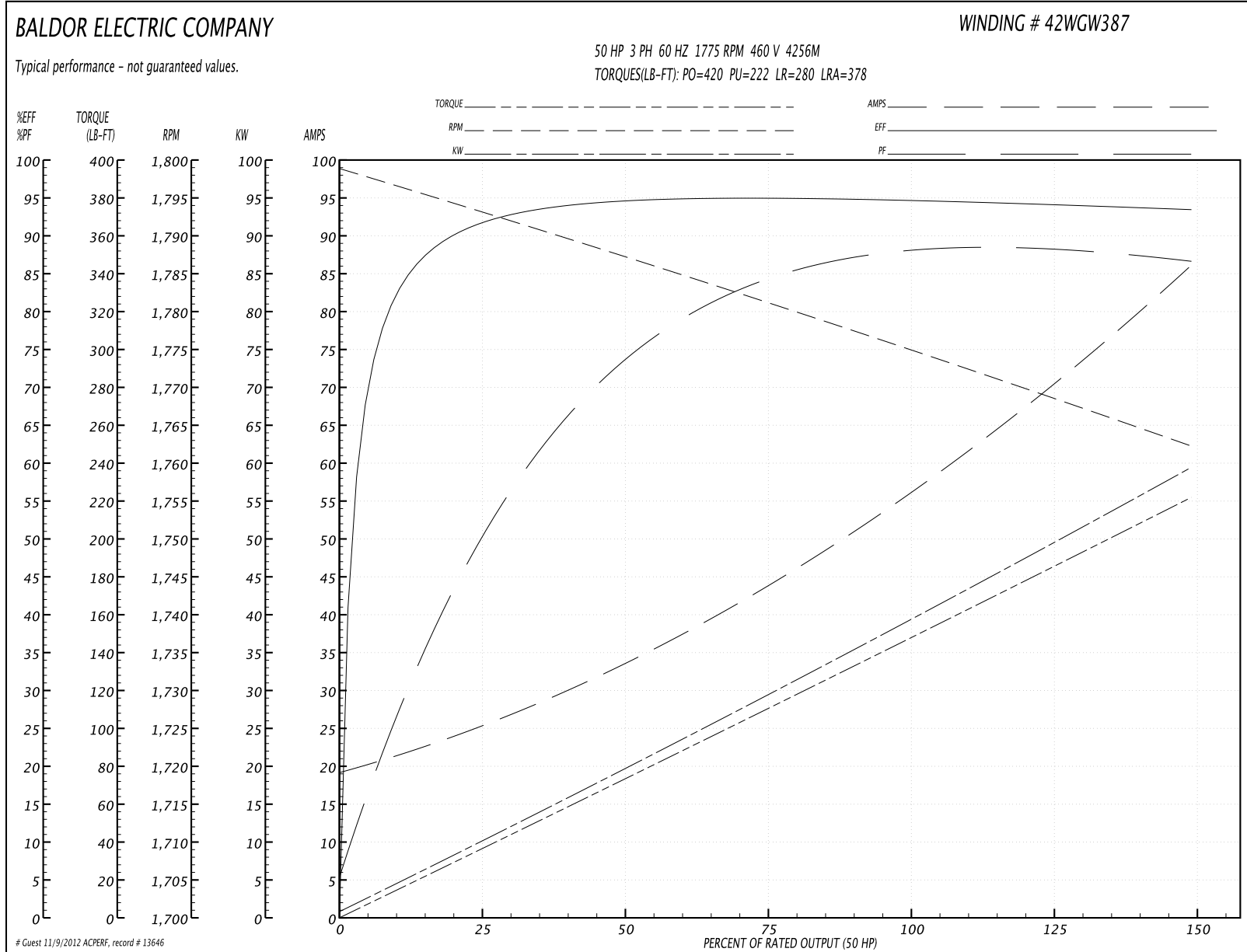

42LYD102

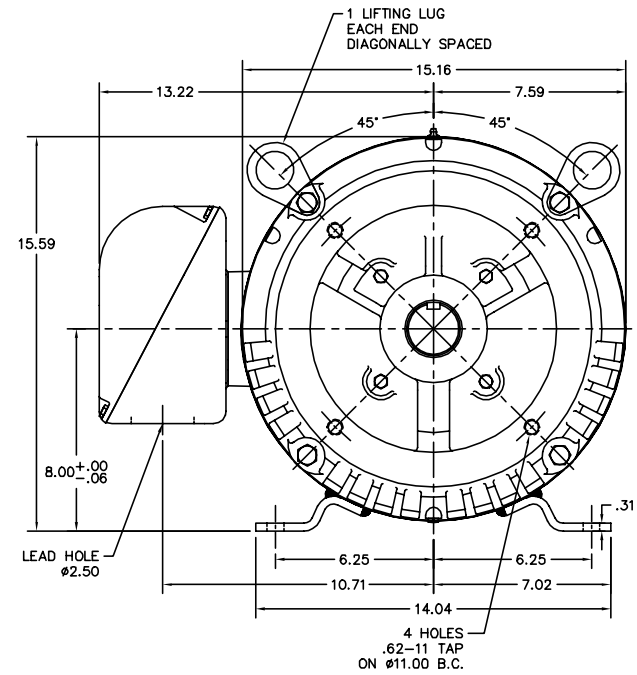
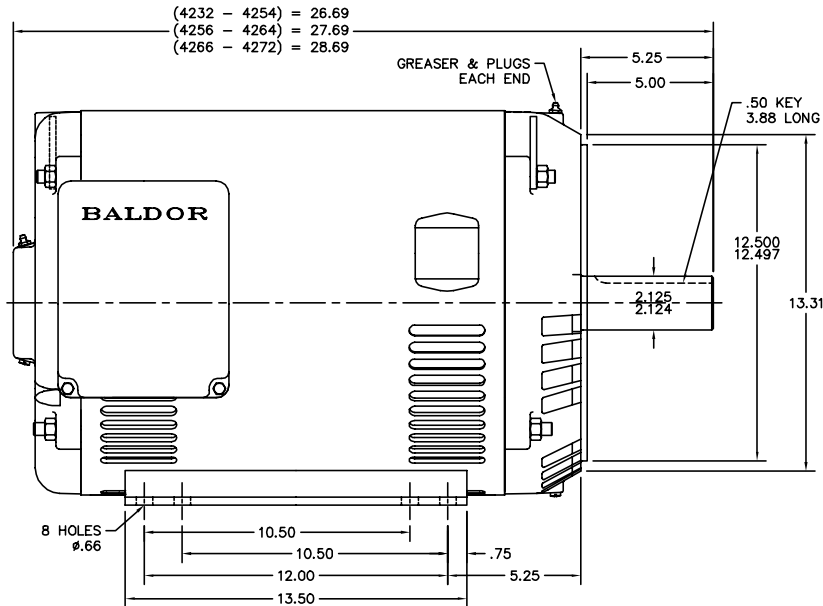

CUSTOMER IS RESPONSIBLE FOR DETERMINING THAT MOTOR PERFORMANCE IS SUITABLE IN THE APPLICATION.

REV. DESC:	CHG'D MAX STACK FOR "D-LENGTH" TO "4264" - EC09
REV. LTR:	F BY: DLS REVISED: 12:16:45 12/04/2002 TDR: 288494
FILE:	AAA00030747 REF: 42LYD102
MTL:	-

**BALDOR ELECTRIC Co.**

STD HOR OPSB 324-6TC

42LYD102

CD0180

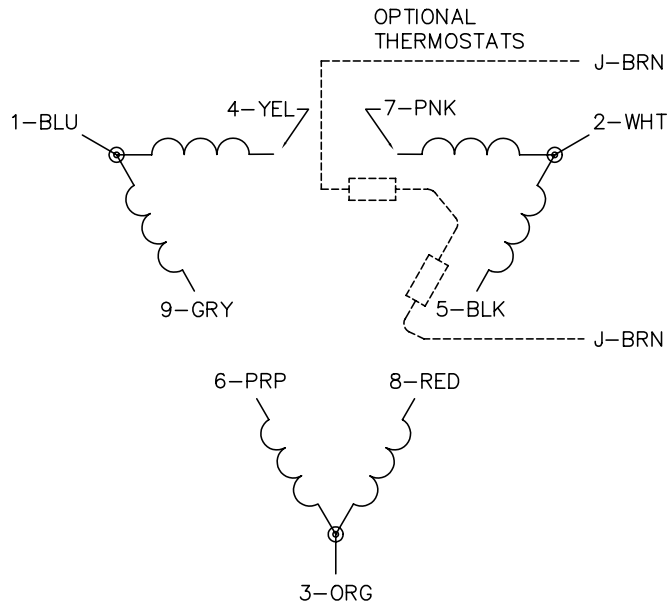

LOW VOLTAGE  
(2D)

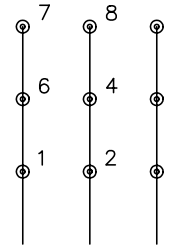

LINE

HIGH VOLTAGE  
(1D)

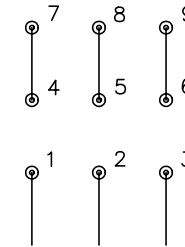

LINE

NOTES:

1. INTERCHANGE ANY TWO LINE LEADS TO REVERSE ROTATION.
2. OPTIONAL THERMOSTATS ARE PROVIDED WHEN SPECIFIED.
3. ACTUAL NUMBER OF INTERNAL PARALLEL CIRCUITS MAY BE A MULTIPLE OF THOSE SHOWN ABOVE.
4. LEAD COLORS ARE OPTIONAL. LEADS MUST ALWAYS BE NUMBERED AS SHOWN.

REV. DESC: REVISE TO SHOW OPTIONAL COLORS			
REV. LTR: C	BY: JLP	REVISED: 01/21/99 2:28	TDR: 0171435
0810D0		FILE: AAA00005148	MDL: -
		MTL: -	

**BALDOR ELECTRIC Co.**

3PH, DV, 9 LEADS, DELTA CONNECTION

CD0180