

BALDOR® • **RELIANCE**

Product Information Packet

CEM3581T

1HP,1760RPM,3PH,60HZ,143TC,0519M,TEFC,F1

Copyright © All product information within this document is subject to Baldor Electric Company copyright © protection, unless otherwise noted.

Part Detail									
Revision:	A	Status:	PRD/A	Change #:		Proprietary:	No		
Type:	AC	Prod. Type:	0519M	Elec. Spec:	05WGX122	CD Diagram:			
Enclosure:	TEFC	Mfg Plant:		Mech. Spec:	05C052	Layout:			
Frame:	143TC	Mounting:	F1	Poles:	04	Created Date:	08-03-2010		
Base:	RG	Rotation:	R	Insulation:	F	Eff. Date:	02-24-2011		
Leads:	9#18	Literature:		Elec. Diagram:		Replaced By:			
Nameplate NP1259L									
CAT.NO.	CEM3581T								
SPEC.	05C052X122G1								
HP	1								
VOLTS	208-230/460								
AMP	3.1-3/1.5								
RPM	1760								
FRAME	143TC	HZ	60	PH	3				
SER.F.	1.15	CODE	L	DES	B	CL	F		
NEMA-NOM-EFF	85.5	PF	71						
RATING	40C AMB-CONT								
CC	010A	USABLE AT 208V	3.1						
DE	6205	ODE	6203						
ENCL	TEFC	SN							

Parts List		
Part Number	Description	Quantity
SA201057	SA 05C052X122G1	1.000 EA
RA188362	RA 05C052X122G1	1.000 EA
34FN3002B01	EXTERNAL FAN, PLASTIC, .637/.639 HUB W/	1.000 EA
S/P107-000-001	SUPER E PROC'S-FS & WS PLTS-POLYREX EM G	1.000 EA
06CB3000	CONDUIT BOX CAST	1.000 EA
06GS1000	GASKET, CONDUIT BOX	1.000 EA
51XW2520A12	.25-20 X .75, TAPTITE II, HEX WSHR SLTD	2.000 EA
11XW1032G06	10-32 X .38, TAPTITE II, HEX WSHR SLTD U	1.000 EA
HW3001B01	003SS CUP WASHER, FOR #8 SCREW	1.000 EA
35EP1100A02	FR ENDPLATE, TEFC W/GREASER	1.000 EA
HW4500A01	1641B(ALEMITE)400 UNIV, GREASE FITT	1.000 EA
HW5100A03SP	WAVY WASHER (W1543-017)	1.000 EA
35EP1329A01	PU EP ENCL 143-5TC 205 BRG W/GRSR & STD	1.000 EA
HW4500A01	1641B(ALEMITE)400 UNIV, GREASE FITT	1.000 EA
51XN1032A20	10-32 X 1 1/4 HX WS SL SR	2.000 EA
HA3100A28	THRUBOLT 10-32 X 8.187	4.000 EA
51XB1214A16	12-14X1.00 HXWSSLD SERTYB	1.000 EA
35FH4005A02SP	IEC FH W/GREASER - W/AUTOPHERETIC PRIMER	1.000 EA
51XW1032A06	10-32 X .38, TAPTITE II, HEX WSHR SLTD S	3.000 EA
06CB3500	CONDUIT BOX LID - ALUMINUM DIE CAST	1.000 EA
06GS1001	GASKET, CONDUIT BOX LID	1.000 EA
51XW2520A12	.25-20 X .75, TAPTITE II, HEX WSHR SLTD	2.000 EA
HW2501D13SP	KEY, 3/16 SQ X 1.375	1.000 EA
HA7000A01	KEY RETAINER 7/8" DIA SHAFT	1.000 EA

Parts List (continued)		
Part Number	Description	Quantity
85XU0407S04	4X1/4 U DRIVE PIN STAINLESS	2.000 EA
MJ1000A75	GREASE, POLYREX EM EXXON	0.050 LB
MG1000Y03	WILKO 689.710 GOLD PAINT SUPER E	0.022 GA
LC0005E01	CONN.DIA./WARNING LABEL (LC0005/LB1119)	1.000 EA
LB1125C02	SUPER-E (STOCK CTN LABEL SUPER-E WITH FL	1.000 EA
LB1357	ENERGY GUIDE LABEL (BOX LABEL)	1.000 SH
NP1259L	ALUM SUPER-E UL CSA-EEV CC NEMA PREMIUM	1.000 EA
36PA1000	PACK GROUP W/LB5001	1.000 EA

Performance Data at 460V, 60Hz, 1.0HP (Typical performance - Not guaranteed values)

General Characteristics			
Full Load Torque:	2.97 LB-FT	Start Configuration:	DOL
No-Load Current:	1.0 Amps	Break-Down Torque:	12.5 LB-FT
Line-line Res. @ 25°C.:	16.05 Ohms A Ph / 0.0 Ohms B Ph	Pull-Up Torque:	6.16 LB-FT
Temp. Rise @ Rated Load:	30 C	Locked-Rotor Torque:	8.49 LB-FT
Temp. Rise @ S.F. Load:	36 C	Starting Current:	12.1 Amps

Load Characteristics							
% of Rated Load	25	50	75	100	125	150	S.F.
Power Factor:	31.0	49.0	62.0	71.0	77.0	80.0	75.0
Efficiency:	72.2	82.1	84.8	85.6	85.3	84.4	85.4
Speed:	1790.9	1781.2	1771.5	1760.7	1749.1	1736.6	1754.0
Line Amperes:	1.05	1.15	1.33	1.54	1.79	2.07	1.69

Performance Graph at 460V, 60Hz, 1.0HP Typical performance - Not guaranteed values

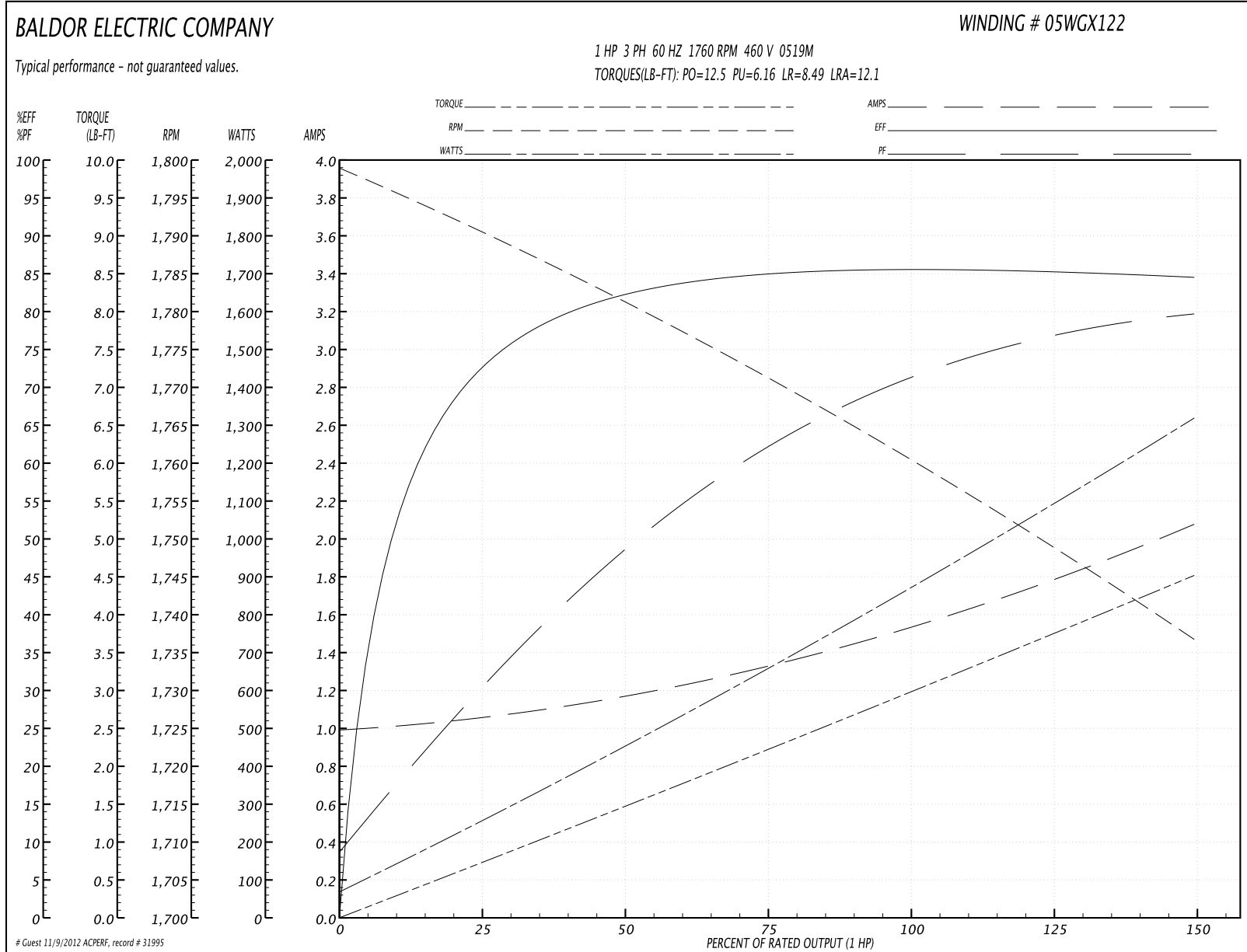

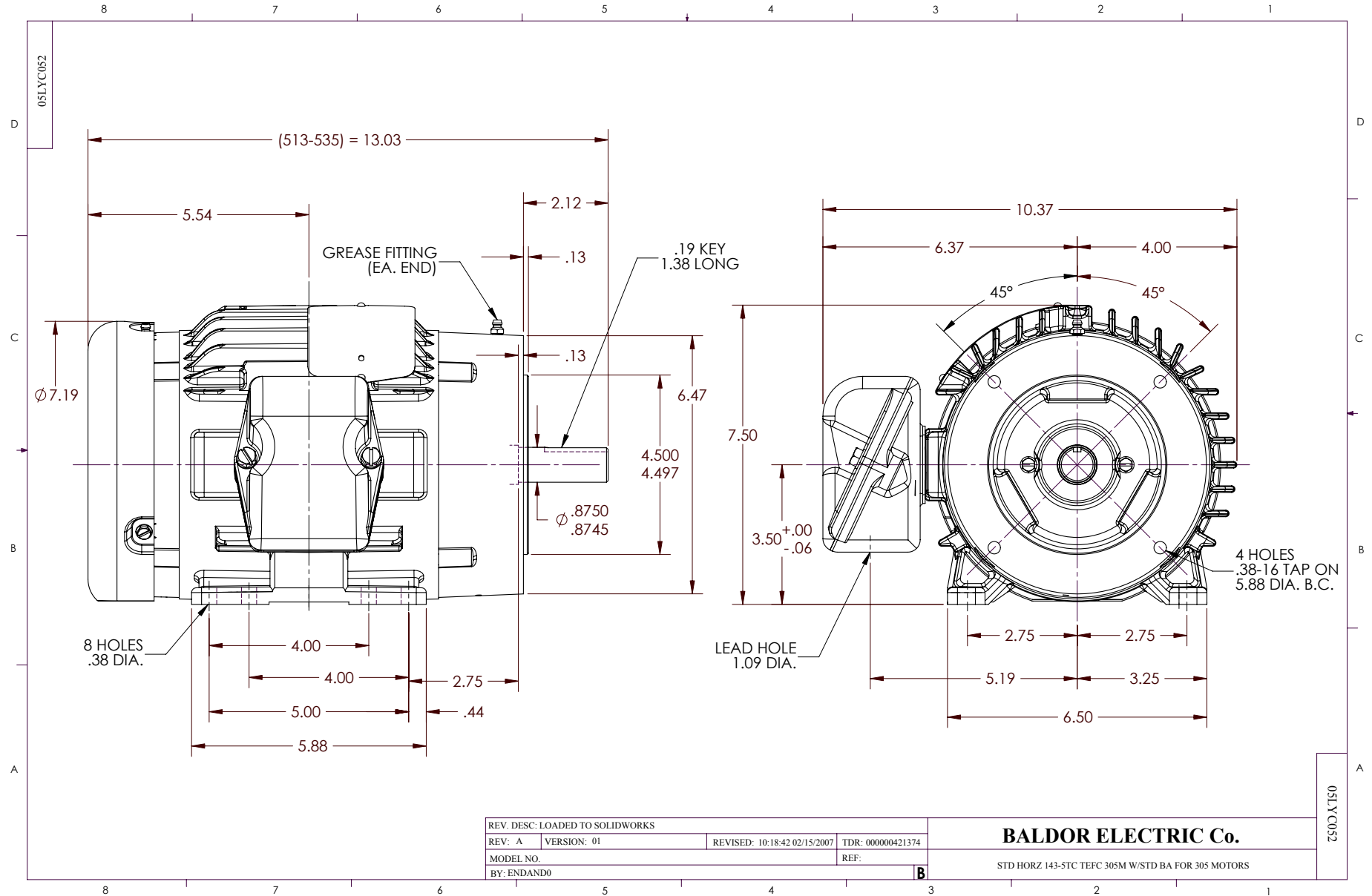

CD0005



LOW VOLTAGE
(2Y)

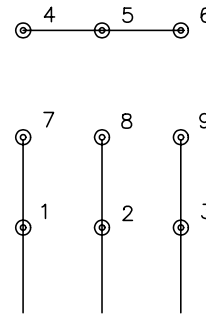

HIGH VOLTAGE
(1Y)

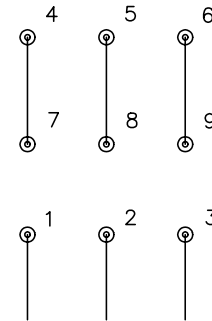

NOTES:

1. INTERCHANGE ANY TWO LINE LEADS TO REVERSE ROTATION.
2. OPTIONAL THERMOSTATS ARE PROVIDED WHEN SPECIFIED.
3. ACTUAL NUMBER OF INTERNAL PARALLEL CIRCUITS MAY BE A MULTIPLE OF THOSE SHOWN ABOVE.
4. LEAD COLORS ARE OPTIONAL. LEADS MUST ALWAYS BE NUMBERED AS SHOWN.

REV. DESC: REVISE TO SHOW OPTIONAL COLORS			
REV. LTR: E	BY: JLP	REVISED: 01/19/99 10:15	TDR: 0171435
90000		FILE: AAA00005140	MDL: -
		MTL: -	

BALDOR ELECTRIC Co.

3PH, DV, 9 LEADS

CD0005