

BALDOR® • RELIANCE

Product Information Packet

CEM3771T

10HP,3490RPM,3PH,60HZ,215TC,0729M,TEFC,F

Copyright © All product information within this document is subject to Baldor Electric Company copyright © protection, unless otherwise noted.

Part Detail									
Revision:	-	Status:	PRD/A	Change #:		Proprietary:	No		
Type:	AC	Prod. Type:	0729M	Elec. Spec:	07WGY855	CD Diagram:			
Enclosure:	TEFC	Mfg Plant:		Mech. Spec:	07H058	Layout:			
Frame:	215TC	Mounting:	F1	Poles:	02	Created Date:	01-27-2012		
Base:	RG	Rotation:	R	Insulation:	F	Eff. Date:	02-02-2012		
Leads:	9#14	Literature:		Elec. Diagram:		Replaced By:			
Nameplate NP1259L									
CAT.NO.	CEM3771T								
SPEC.	07H058Y855G1								
HP	10								
VOLTS	230/460								
AMP	23.6/11.8								
RPM	3490								
FRAME	215TC	HZ	60			PH	3		
SER.F.	1.15	CODE	G			DES	B	CL	F
NEMA-NOM-EFF	90.2	PF	87						
RATING	40C AMB-CONT								
CC	010A	USABLE AT 208V							
DE	6307	ODE	6206						
ENCL	TEFC	SN							

Parts List		
Part Number	Description	Quantity
SA238142	SA 07H058Y855G1	1.000 EA
RA225069	RA 07H058Y855G1	1.000 EA
36FN3000C02	EXFN, PLASTIC, 5.25 OD, 1.175 ID	1.000 EA
S/P107-000-001	SUPER E PROC'S-FS & WS PLTS-POLYREX EM G	1.000 EA
HW3201A05	3/8-16 EYEBOLT	1.000 EA
09CB3002SP	CB W/1.38 LEAD HOLE FOR 37, 39, 307 & 30	1.000 EA
09GS1000SP	GASKET-CONDUIT BOX, 1/16 THICK LEXIDE	1.000 EA
51XW2520A12	.25-20 X .75, TAPTITE II, HEX WSHR SLTD	2.000 EA
11XW1032G06	10-32 X .38, TAPTITE II, HEX WSHR SLTD U	1.000 EA
HW3001B02	BRASS CUP WASHER W/GROUND SYMBOL TAB,	1.000 EA
37EP1100A41	FR ENDPLATE MACH FOR GREASER & RELIEF	1.000 EA
HW4500A17	317400 ALEMITE GREASE RELIEF	1.000 EA
HW4500A01	1641B(ALEMITE)400 UNIV, GREASE FITT	1.000 EA
HW5100A06	W2420-025 WVY WSHR (WB)	1.000 EA
37EP1300A10	FACE MTD EP,307BRG,213-5TC,GRSR,RELIEF &	1.000 EA
HW4500A17	317400 ALEMITE GREASE RELIEF	1.000 EA
HW4500A01	1641B(ALEMITE)400 UNIV, GREASE FITT	1.000 EA
10XN2520A30	HEX HD CAP SCREW-STD THD-.25 X 20 THD PE	4.000 EA
HW1001A25	LOCKWASHER 1/4, ZINC PLT .493 OD, .255 I	4.000 EA
XY3118A12	5/16-18 HEX NUT DIRECTIONAL SERRATION	4.000 EA
51XB1214A20	12-14X1.25 HXWSSLD SERTYB	1.000 EA
07FH4007SP	IEC FH W/GRSR, NOTCH @ 6:00 & 3 FAN CVR	1.000 EA
51XW1032A06	10-32 X .38, TAPTITE II, HEX WSHR SLTD S	3.000 EA
09CB3501SP	CONDUIT BOX LID FOR 09CB3001 & 09CB3002	1.000 EA

Parts List (continued)		
Part Number	Description	Quantity
09GS1013SP	09 GS FOR 09CB3501 LID - LEXIDE	1.000 EA
51XW2520A12	.25-20 X .75, TAPTITE II, HEX WSHR SLTD	2.000 EA
HW2501F21	KEY, 5/16 SQ X 2.375	1.000 EA
HA7000A02	KEY RETAINER RING, 1 1/8 DIA, 1 3/8 DIA	1.000 EA
85XU0407S04	4X1/4 U DRIVE PIN STAINLESS	2.000 EA
LB1115	LABEL,LIFTING DEVICE	1.000 EA
MJ1000A75	GREASE, POLYREX EM EXXON	0.050 LB
HA3104A32	THRUBOLT- 5/16-18 X12.750	4.000 EA
MG1000Y03	WILKO 689.710 GOLD PAINT SUPER E	0.036 GA
LC0005E01	CONN.DIA./WARNING LABEL (LC0005/LB1119)	1.000 EA
LB1125C02	SUPER-E (STOCK CTN LABEL SUPER-E WITH FL	1.000 EA
LB1357	ENERGY GUIDE LABEL (BOX LABEL)	1.000 SH
NP1259L	ALUM SUPER-E UL CSA-EEV CC NEMA PREMIUM	1.000 EA
07PA1011	PKG GRP, 07 CAST IRON PK1181	1.000 EA

Performance Data at 460V, 60Hz, 10.0HP (Typical performance - Not guaranteed values)

General Characteristics							
Full Load Torque:	15.1 LB-FT			Start Configuration:	DOL		
No-Load Current:	4.0 Amps			Break-Down Torque:	53.8 LB-FT		
Line-line Res. @ 25°C.:	1.0281 Ohms A Ph / 0.0 Ohms B Ph			Pull-Up Torque:	20.7 LB-FT		
Temp. Rise @ Rated Load:	61 C			Locked-Rotor Torque:	28.8 LB-FT		
Temp. Rise @ S.F. Load:	77 C			Starting Current:	77.6 Amps		
Load Characteristics							
% of Rated Load	25	50	75	100	125	150	S.F.
Power Factor:	57.0	77.0	86.0	89.0	90.0	90.0	90.0
Efficiency:	88.1	91.5	91.7	90.8	89.4	87.7	90.0
Speed:	3576.4	3552.0	3526.4	3496.4	3463.3	3425.3	3477.0
Line Amperes:	4.73	6.58	8.97	11.6	14.6	17.8	13.4

Performance Graph at 460V, 60Hz, 10.0HP Typical performance - Not guaranteed values

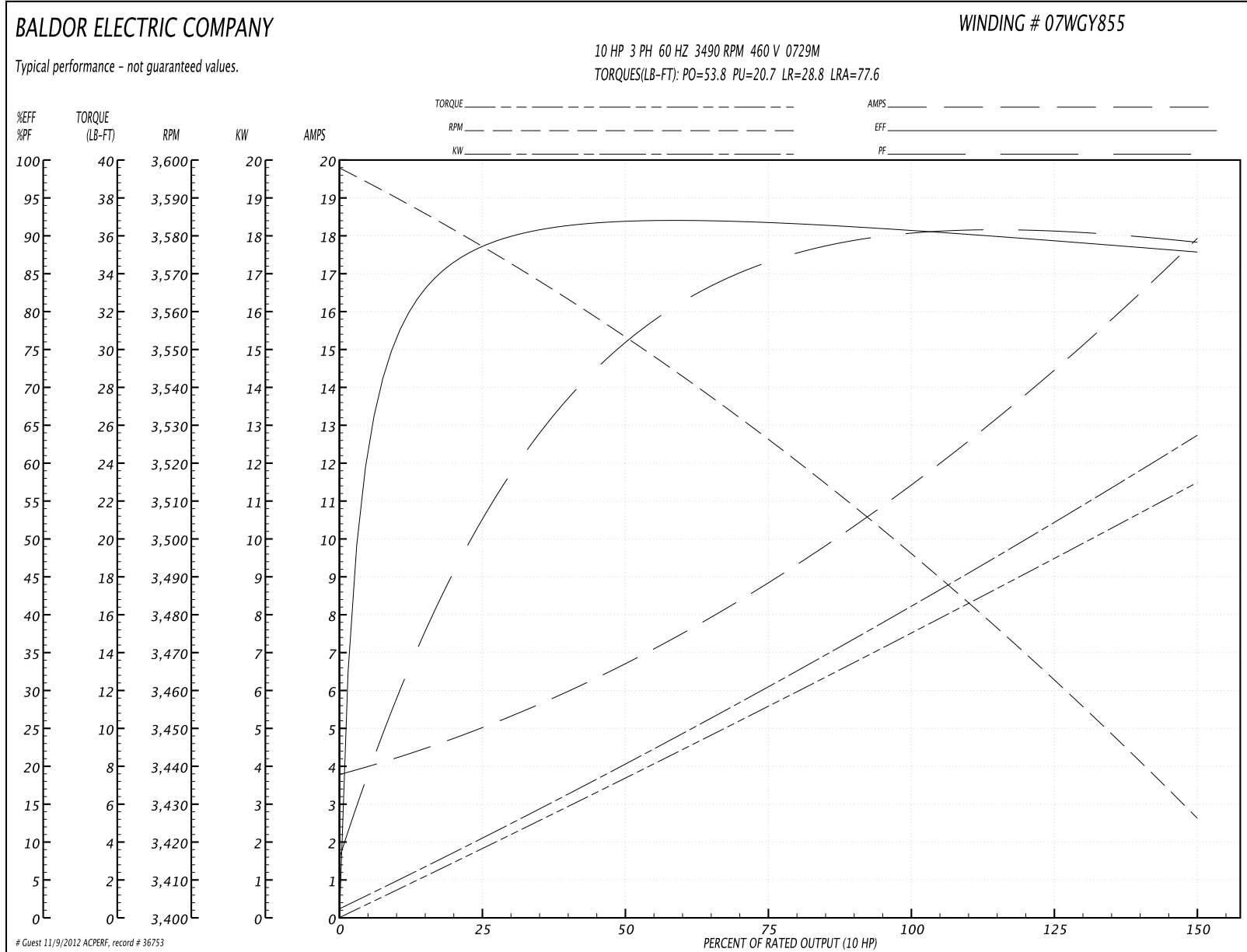

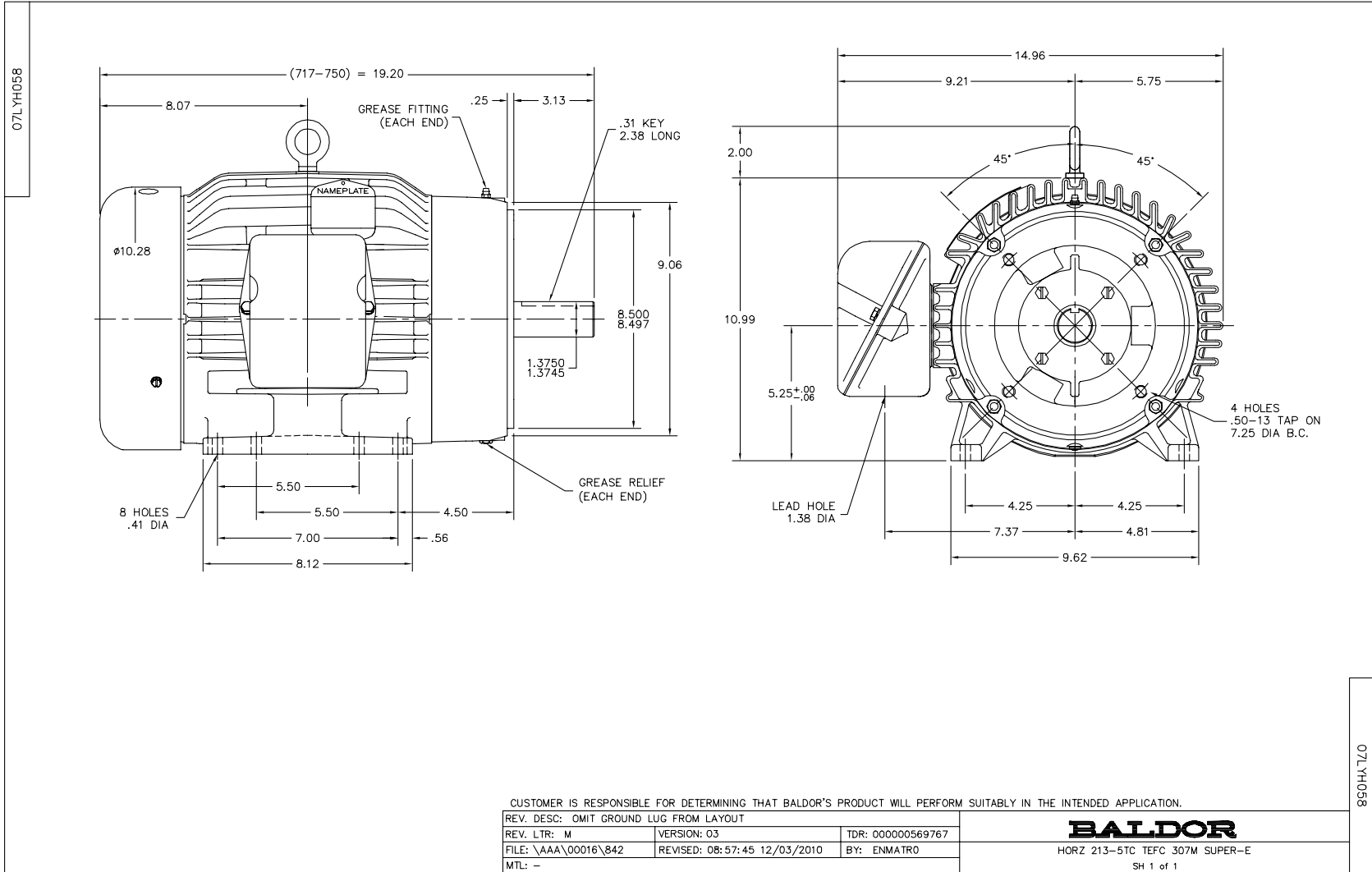

CD0005

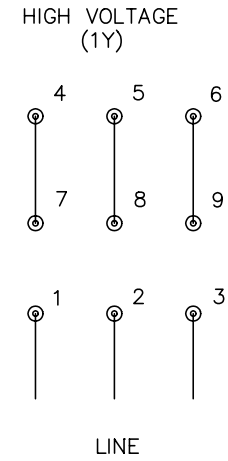
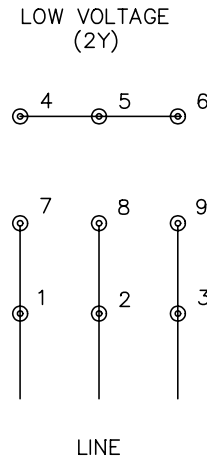

NOTES:

1. INTERCHANGE ANY TWO LINE LEADS TO REVERSE ROTATION.
2. OPTIONAL THERMOSTATS ARE PROVIDED WHEN SPECIFIED.
3. ACTUAL NUMBER OF INTERNAL PARALLEL CIRCUITS MAY BE A MULTIPLE OF THOSE SHOWN ABOVE.
4. LEAD COLORS ARE OPTIONAL. LEADS MUST ALWAYS BE NUMBERED AS SHOWN.

REV. DESC: REVISE TO SHOW OPTIONAL COLORS			
REV. LTR: E	BY: JLP	REVISED: 01/19/99 10:15	TDR: 0171435
90000		FILE: AAA00005140	MDL: -
		MTL: -	

BALDOR ELECTRIC Co.

3PH, DV, 9 LEADS

CD0005