

# **BALDOR**® • ***RELIANCE***

## **Product Information Packet**

# **CESSWDM23994T**

**15HP,3520RPM,3PH,60HZ,254TC,3952M,TEFC,F**

Copyright © All product information within this document is subject to Baldor Electric Company copyright © protection, unless otherwise noted.

Part Detail							
Revision:	P	Status:	PRD/A	Change #:		Proprietary:	No
Type:	AC	Prod. Type:	3952M	Elec. Spec:	39WGX633	CD Diagram:	
Enclosure:	TEFC	Mfg Plant:		Mech. Spec:	39E119	Layout:	
Frame:	254TC	Mounting:	F1	Poles:	02	Created Date:	03-18-2008
Base:	RG	Rotation:	R	Insulation:	F	Eff. Date:	01-19-2012
Leads:	9#12	Literature:		Elec. Diagram:		Replaced By:	

Parts List		
Part Number	Description	Quantity
SA169249	SA 39E119X633G1	1.000 EA
RA157525	RA 39E119X633G1	1.000 EA
09FN3001C01SP	EXTERNAL FAN, PLASTIC	1.000 EA
S/P107-000-005	SUPER-E PROC'S(254/6 FR.) ZK PLANT - POL	1.000 EA
WD1000B17	KPA-8C BURNDY TERMINAL	1.000 EA
11XW1032S06	10-32 X .38, TAPTITE II, HEX WSHR SLTD U	1.000 EA
39EP1901A01	S.S. FR ENDPLATE, MACH	1.000 EA
HW5100A08	W3118-035 WVY WSHR (WB)	1.000 EA
HW4606A16	JM CLIPPER/SEAL (WDE-1575-2125-BG38)	1.000 EA
39EP1903A01	S.S. C-FACE PU ENDPLATE, MACH	1.000 EA
10XN2520S28	1/4-20X 1 3/4 HEX HD SS X	4.000 EA
HW4606A15	JM CLIPPER/SEAL (WDE-1688-2250-BG37)	1.000 EA
XY3816S12	3/8-16 HEX FINISHED NUT SS	8.000 EA
09FH4014A01	304 S.S. FAN COVER & GRILL W/#4 FINISH	1.000 EA
10XN2520S08	SCREW, 1/4-20 X 1/2 HHCS SS	3.000 EA
HW1001S25	WASHER, 1/4 SPLT LK, STAINLESS STEEL	3.000 EA
09CB1505A01	S.S. LIPPED KOBX LID	1.000 EA
12GS1002	GASKET, CONDUIT BOX LID, NEOP	1.000 EA
10XN3118S12	5/16-18 X 3/4 HEX HEAD CAP, STAINLESS ST	2.000 EA
HW1001S31	WASHER, 5/16 SPLT LK, STAINLESS STEEL	2.000 EA
HW2502G25	#303 SS,SQ KEY 3/8 X 2.880	1.000 EA
MJ5002A02	NON-CORROSIVE SILICONE, DOW 748, 10.3 OZ	0.031 EA
LB5040	INSTRUCTION TAG, AC & DC	1.000 EA
HW4032A01	BLACK DRAIN PLUG FOR WASH DOWN MOTORS	3.000 EA

Parts List (continued)		
Part Number	Description	Quantity
MJ1000A75	GREASE, POLYREX EM EXXON	0.030 LB
HW4032A01	BLACK DRAIN PLUG FOR WASH DOWN MOTORS	3.000 EA
HA3154S06	THRUBOLT STUD 3/8-16 X 16.875 SS	4.000 EA
HW2500S25	USA#1008-WOODRUFF KEY#B STAINLESS:	1.000 EA
51XB1214A20	12-14X1.25 HXWSSLD SERTYB	1.000 EA
LB1125C02	SUPER-E (STOCK CTN LABEL SUPER-E WITH FL	4.000 EA
LB1357	ENERGY GUIDE LABEL (BOX LABEL)	1.000 SH
39PA1000	PACKAGING GROUP 39 PRINT	1.000 EA

**Performance Data at 460V, 60Hz, 15.0HP (Typical performance - Not guaranteed values)**

General Characteristics							
Full Load Torque:	22.1 LB-FT			Start Configuration:	DOL		
No-Load Current:	4.77 Amps			Break-Down Torque:	100.0 LB-FT		
Line-line Res. @ 25°C.:	0.467 Ohms A Ph / 0.0 Ohms B Ph			Pull-Up Torque:	36.4 LB-FT		
Temp. Rise @ Rated Load:	73 C			Locked-Rotor Torque:	47.4 LB-FT		
Temp. Rise @ S.F. Load:	87 C			Starting Current:	145.0 Amps		
Load Characteristics							
% of Rated Load	25	50	75	100	125	150	S.F.
Power Factor:	66.0	84.0	90.0	92.0	93.0	93.0	93.0
Efficiency:	83.9	89.6	91.1	91.3	90.8	90.1	91.0
Speed:	3579.0	3563.0	3546.0	3528.0	3507.0	3486.0	3515.0
Line Amperes:	6.39	9.25	12.8	16.5	20.6	24.9	19.0

Performance Graph at 460V, 60Hz, 15.0HP Typical performance - Not guaranteed values

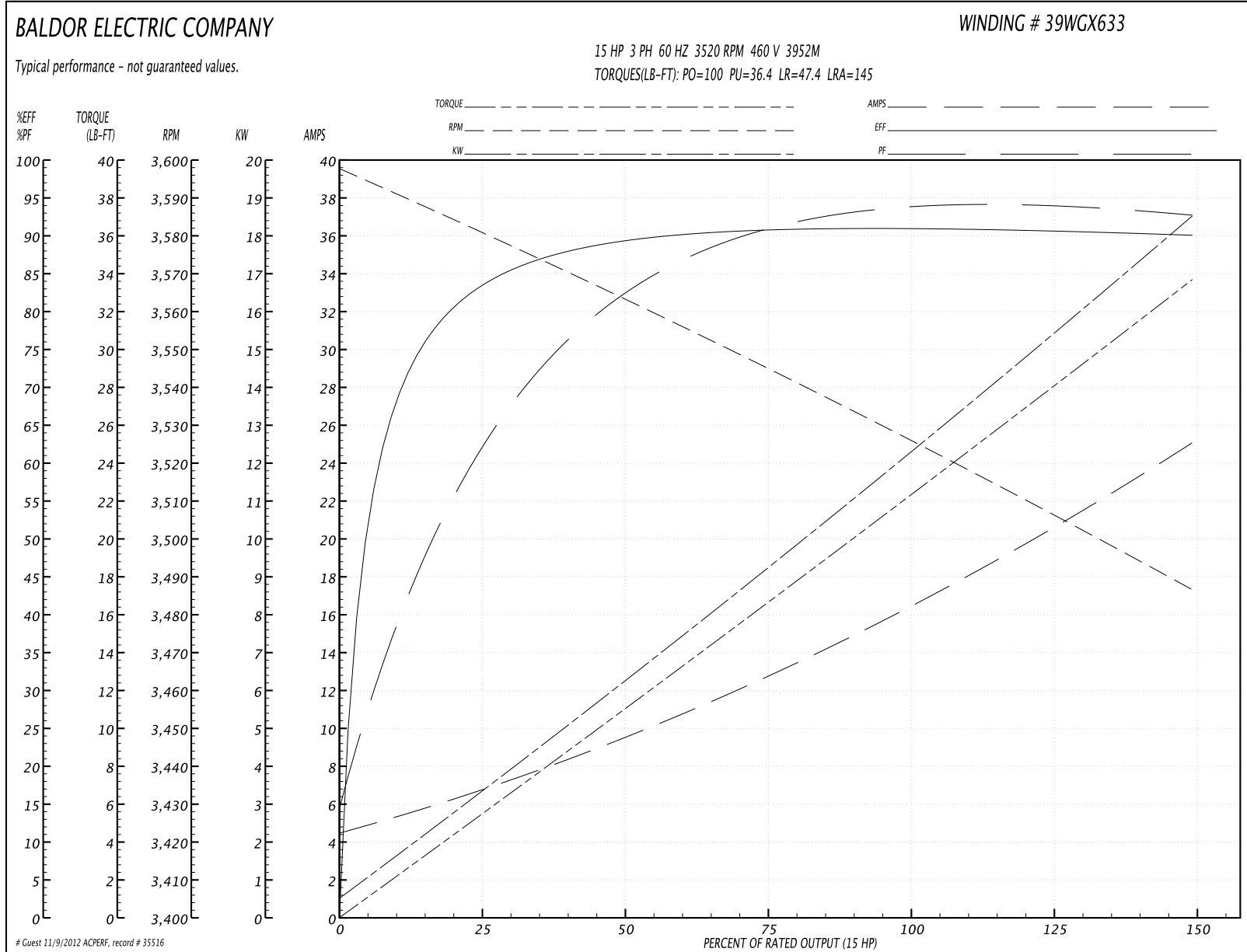

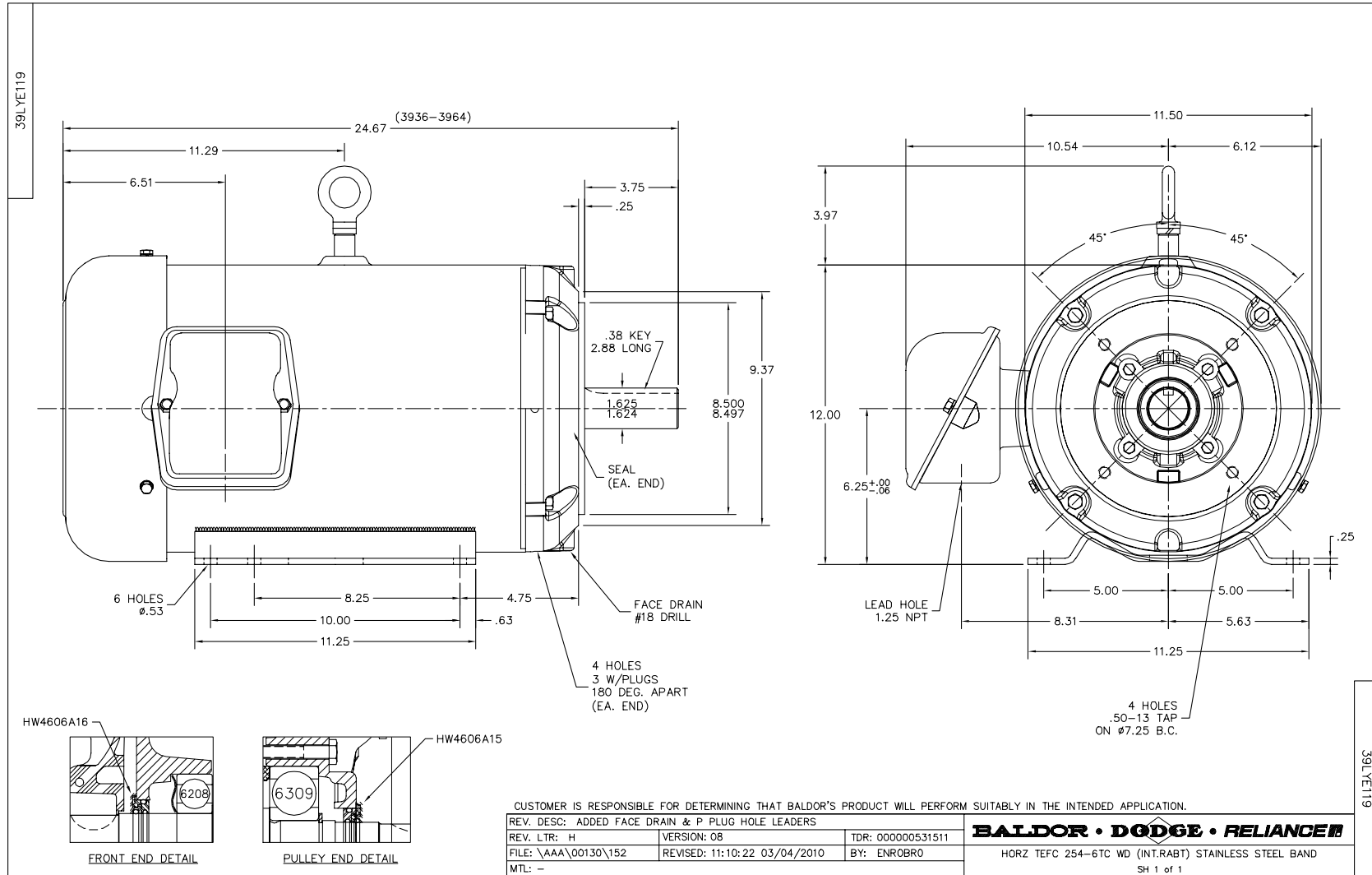

CD0005



LOW VOLTAGE  
(2Y)

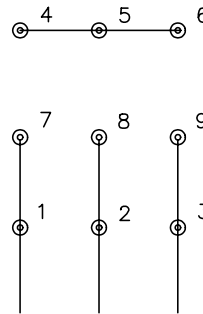

LINE

HIGH VOLTAGE  
(1Y)

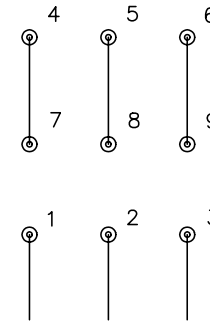

LINE

NOTES:

1. INTERCHANGE ANY TWO LINE LEADS TO REVERSE ROTATION.
2. OPTIONAL THERMOSTATS ARE PROVIDED WHEN SPECIFIED.
3. ACTUAL NUMBER OF INTERNAL PARALLEL CIRCUITS MAY BE A MULTIPLE OF THOSE SHOWN ABOVE.
4. LEAD COLORS ARE OPTIONAL. LEADS MUST ALWAYS BE NUMBERED AS SHOWN.

REV. DESC: REVISE TO SHOW OPTIONAL COLORS			
REV. LTR: E	BY: JLP	REVISED: 01/19/99 10:15	TDR: 0171435
90000		FILE: AAA00005140	MDL: -
		MTL: -	

**BALDOR ELECTRIC Co.**

3PH, DV, 9 LEADS

CD0005