

BALDOR® • *RELIANCE*

Product Information Packet

CESSWDM3546T

1HP, 1760RPM, 3PH, 60HZ, 143TC, 3524M, TEFC, F1

Copyright © All product information within this document is subject to Baldor Electric Company copyright © protection, unless otherwise noted.

Part Detail							
Revision:	E	Status:	PRD/A	Change #:		Proprietary:	No
Type:	AC	Prod. Type:	3524M	Elec. Spec:	35WGP529	CD Diagram:	
Enclosure:	TEFC	Mfg Plant:		Mech. Spec:	35VV818	Layout:	
Frame:	143TC	Mounting:	F1	Poles:	04	Created Date:	02-22-2010
Base:	RG	Rotation:	R	Insulation:	F	Eff. Date:	04-02-2012
Leads:	9#18	Literature:		Elec. Diagram:		Replaced By:	

Parts List		
Part Number	Description	Quantity
SA191170	SA 35VV818P529G1	1.000 EA
RA178832	RA 35VV818P529G1	1.000 EA
NS2512A01	INSULATOR, CONDUIT BOX X	1.000 EA
35CB5001A17	KOBX KIT, (ALL STAINLESS) W/ .75 NPT	1.000 EA
11XW1032G06	10-32 X .38, TAPTITE II, HEX WSHR SLTD U	1.000 EA
HW3001B01	003SS CUP WASHER, FOR #8 SCREW	1.000 EA
35EP1913A02	FR EP MADE FROM 35EP1913A01	1.000 EA
HW4500A33	1/8 NPT STAINLESS,HOLO-KROME #13002,PRES	3.000 EA
HW4606A01	JM CLIPPER/SEAL (WDE-0667-1064-BH49)	1.000 EA
HW5100A03SP	WAVY WASHER (W1543-017)	1.000 EA
35PE1914A02	PU EP ASSY. FOR LOCKED BRG	1.000 EA
HW4606A02	JM CLIPPER/SEAL (LWE-0938-1624-AL23)	1.000 EA
12XN1032S22	10-32 X 1 3/8 SLOT HEX, STAINLESS STEEL	2.000 EA
HA1049A01	DUBO LOK WASHER SIZE 10 (NYLON LOCK SEAL	2.000 EA
HA1049A01	DUBO LOK WASHER SIZE 10 (NYLON LOCK SEAL	4.000 EA
51XB1214A16	12-14X1.00 HXWSSLD SERTYB	1.000 EA
35FH4005A39	IEC FH NO GREASER (#304 SS)CLEAN ONLY	1.000 EA
10XN1032S06	HEX HD CAP SCREW, SS	3.000 EA
HW2502D13	SS KEY, 3/16 SQ X 1.375	1.000 EA
HA7000A01	KEY RETAINER 7/8" DIA SHAFT	1.000 EA
MJ5001A02	732 CL SEALANT 3 OZ DIXIE BEARING 289100	0.001 EA
MJ1000A75	GREASE, POLYREX EM EXXON	0.050 LB
35FN3002A05SP	EXFN, PLASTIC, 6.376 OD, .638 ID	1.000 EA
HA3100S14	THRUBOLT 10X32 X 8.875 302 OR 303 SS	4.000 EA

Parts List (continued)		
Part Number	Description	Quantity
LB1357	ENERGY GUIDE LABEL (BOX LABEL)	1.000 SH
LB1125C02	SUPER-E (STOCK CTN LABEL SUPER-E WITH FL	1.000 EA
36PA1000	PACK GROUP W/LB5001	1.000 EA

Performance Data at 460V, 60Hz, 1.0HP (Typical performance - Not guaranteed values)

General Characteristics			
Full Load Torque:	2.98 LB-FT	Start Configuration:	DOL
No-Load Current:	1.01 Amps	Break-Down Torque:	15.8 LB-FT
Line-line Res. @ 25°C.:	11.859 Ohms A Ph / 0.0 Ohms B Ph	Pull-Up Torque:	9.1 LB-FT
Temp. Rise @ Rated Load:	67 C	Locked-Rotor Torque:	11.0 LB-FT
Temp. Rise @ S.F. Load:	78 C	Starting Current:	15.0 Amps

Load Characteristics							
% of Rated Load	25	50	75	100	125	150	S.F.
Power Factor:	30.0	47.0	61.0	70.0	76.0	80.0	74.0
Efficiency:	74.6	83.5	86.5	87.3	87.2	86.7	87.2
Speed:	1791.9	1783.8	1775.4	1767.0	1757.7	1747.8	1761.0
Line Amperes:	1.05	1.18	1.34	1.55	1.78	2.04	1.69

Performance Graph at 460V, 60Hz, 1.0HP Typical performance - Not guaranteed values

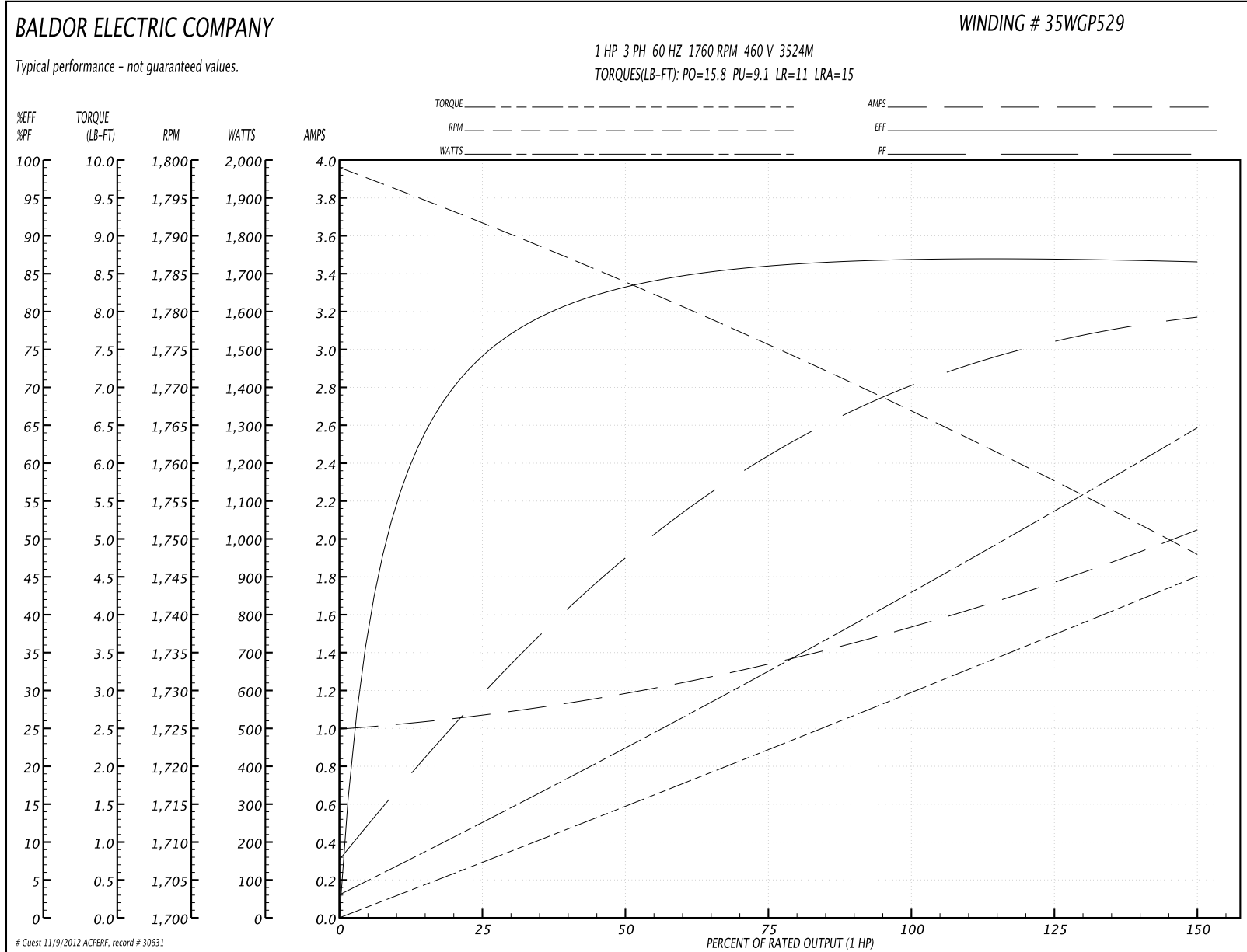

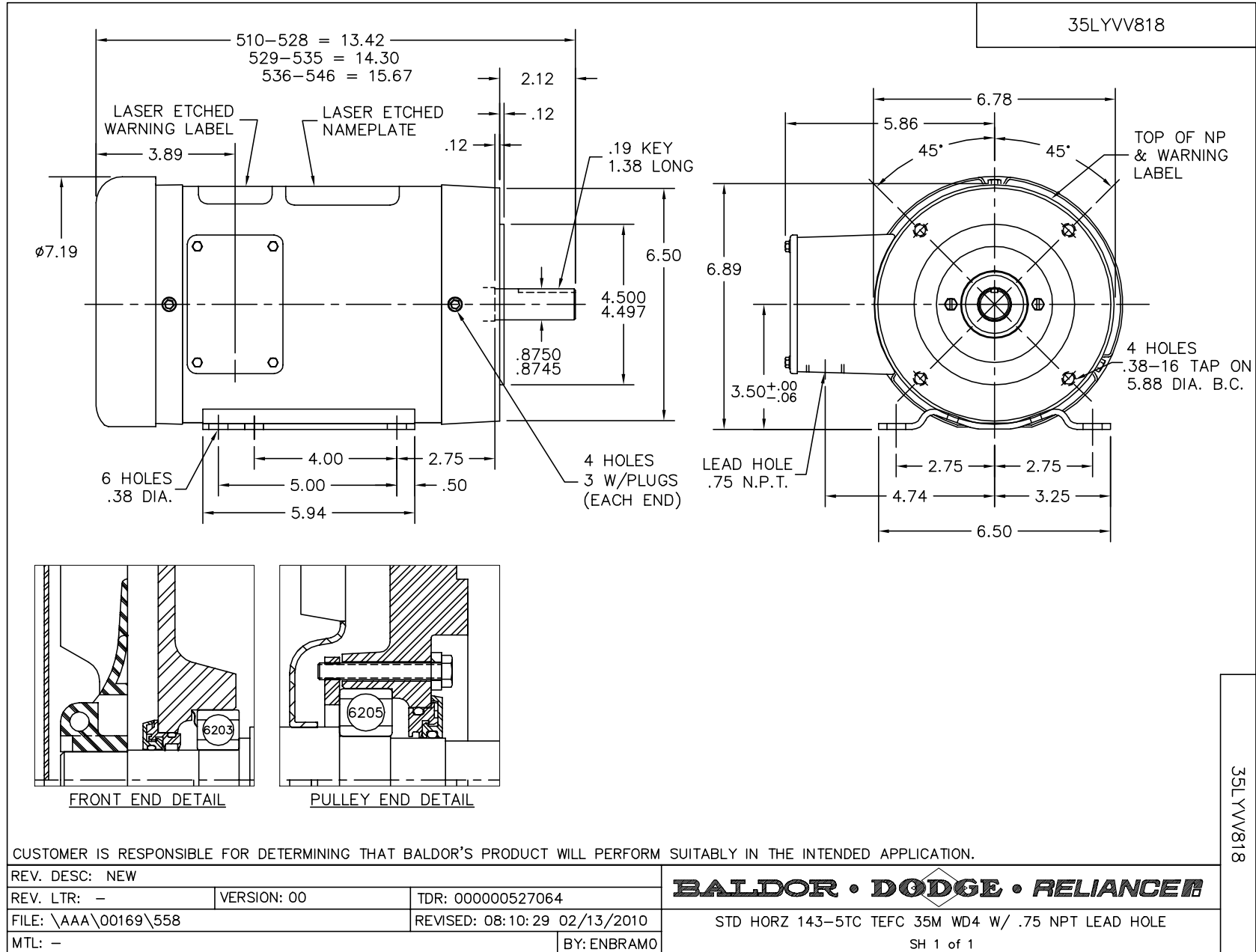

CD0005

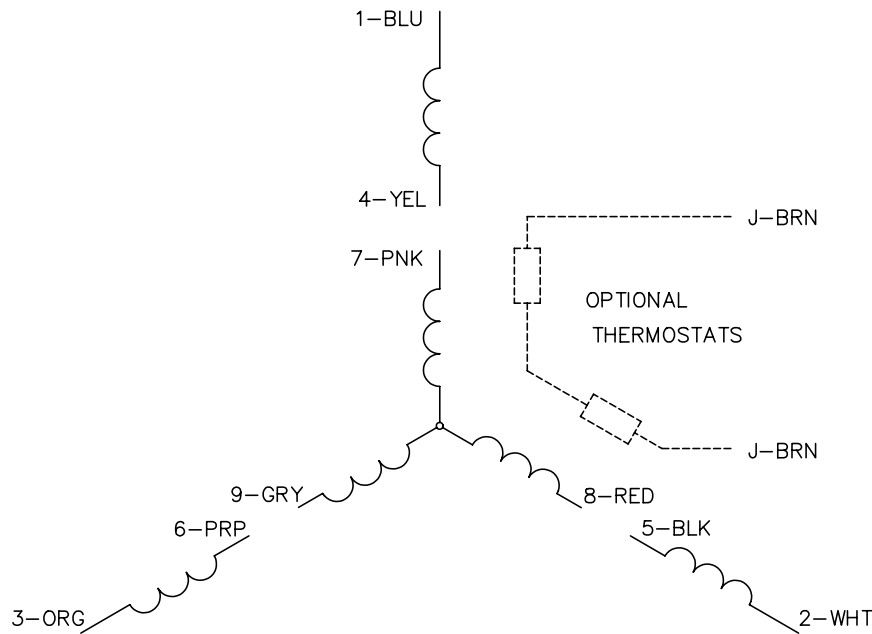

LOW VOLTAGE (2Y)

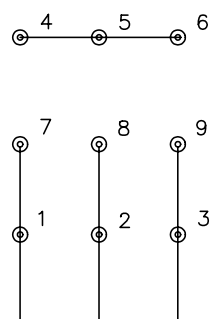

LINE

HIGH VOLTAGE (1Y)

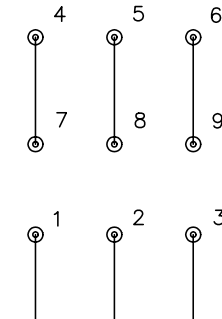

LINE

NOTES:

1. INTERCHANGE ANY TWO LINE LEADS TO REVERSE ROTATION.
2. OPTIONAL THERMOSTATS ARE PROVIDED WHEN SPECIFIED.
3. ACTUAL NUMBER OF INTERNAL PARALLEL CIRCUITS MAY BE A MULTIPLE OF THOSE SHOWN ABOVE.
4. LEAD COLORS ARE OPTIONAL. LEADS MUST ALWAYS BE NUMBERED AS SHOWN.

REV. DESC: REVISE TO SHOW OPTIONAL COLORS			
REV. LTR: E	BY: JLP	REVISED: 01/19/99 10:15	TDR: 0171435
90000		FILE: AAA00005140	MDL: -
		MTL: -	

BALDOR ELECTRIC Co.

3PH, DV, 9 LEADS

CD0005