

BALDOR® • **RELIANCE**

Product Information Packet

CEWDM23934T-5

20HP, 1765RPM, 3PH, 60HZ, 256TC, 3952M, TEFC, F

Copyright © All product information within this document is subject to Baldor Electric Company copyright © protection, unless otherwise noted.

Part Detail							
Revision:	T	Status:	PRD/A	Change #:		Proprietary:	No
Type:	AC	Prod. Type:	3952M	Elec. Spec:	39WGX438	CD Diagram:	
Enclosure:	TEFC	Mfg Plant:		Mech. Spec:	39R098	Layout:	
Frame:	256TC	Mounting:	F1	Poles:	04	Created Date:	
Base:	RG	Rotation:	R	Insulation:	F	Eff. Date:	03-13-2012
Leads:	3#12	Literature:		Elec. Diagram:		Replaced By:	

Nameplate NP1669E

CAT.NO.	CEWDM23934T-5						
SPEC.	39R098X438G1						
HP	20						
VOLTS	575						
AMP	19						
RPM	1765						
FRAME	256TC	HZ	60	PH	3		
SER.F.	1.15	CODE	H	DES	B	CLASS	F
NEMA-NOM-EFF	93	PF	84				
RATING	40C AMB-CONT						
CC	010A	USABLE AT 208V					
DE	6309	ODE	6208				
ENCL	TEFC	SN					
BLANK							

Parts List		
Part Number	Description	Quantity
SA115919	SA 39R098X438G1	1.000 EA
RA106935	RA 39R098X438G1	1.000 EA
S/P107-000-005	SUPER-E PROC'S(254/6 FR.) ZK PLANT - POL	1.000 EA
MJ5002A01	SILICON RUBBER SEALANT, 732CL 10.3 OZ TU	0.025 EA
HA6016WHP	ADAPTER, CONDUIT BOX, W/WHITE EPOXY, PRIM	1.000 EA
09GS1006	GASKET, CONDUIT BOX, NEOP-1/16 THICK-BLA	1.000 EA
09CB3002A01P	CB MACH - 1.25 N.P.T. LEAD HOLE W/EPOXY	1.000 EA
51XW2520A12	.25-20 X .75, TAPTITE II, HEX WSHR SLTD	2.000 EA
HW1001A25	LOCKWASHER 1/4, ZINC PLT .493 OD, .255 I	2.000 EA
WD1000B17	KPA-8C BURNDY TERMINAL	1.000 EA
11XW1032G06	10-32 X .38, TAPTITE II, HEX WSHR SLTD U	1.000 EA
39EP1100A08WP	FR ENDPLATE, MACH W/WHITE EPOXY, PRIMED	1.000 EA
HW5100A08	W3118-035 WVY WSHR (WB)	1.000 EA
HW4600B44SP	V-RING SLINGER 1.500 X 2.290 X 0.280	1.000 EA
39EP1500A04P	PU ENDPLATE, MACH W/EPOXY PRIMER	1.000 EA
10XN2520S28	1/4-20X 1 3/4 HEX HD SS X	4.000 EA
HW4600B44SP	V-RING SLINGER 1.500 X 2.290 X 0.280	1.000 EA
HA3154S02	THRUBOLT STUD 3/8-16 X 15.875 SS	4.000 EA
XY3816S12	3/8-16 HEX FINISHED NUT SS	8.000 EA
HA2001B08	SPL SPACER FOR AIR DEFLECTOR .50 O.D. X	3.000 EA
09FH4000A23MWP	FAN COVER, MACH W/WHITE EPOXY	1.000 EA
10XN2520S16	41/4-20 X 1 HEX HEAD SS	3.000 EA
09CB3501P	CONDUIT BOX LID FOR 09CB3001 & 09CB3002	1.000 EA
12GS1002	GASKET, CONDUIT BOX LID, NEOP	1.000 EA

Parts List (continued)		
Part Number	Description	Quantity
19XT2520S12	1/4-20X3/4 HWH NO SLOT TY.23 18-8 S.S.	2.000 EA
HW1001S25	WASHER, 1/4 SPLT LK, STAINLESS STEEL	2.000 EA
HW4600B53	SEAL 1.688 X 2.275 X 0.312 SINGLE LIP DB	1.000 EA
HW2502G25	#303 SS,SQ KEY 3/8 X 2.880	1.000 EA
MJ5001A01	46-665 RED SEALER	0.031 QT
LB1115	LABEL,LIFTING DEVICE	1.000 EA
07GS1000SP	GASKET, CONDUIT BOX, .125 THICK BLACK NE	1.000 EA
HW4032A01	BLACK DRAIN PLUG FOR WASH DOWN MOTORS	3.000 EA
MJ1000A75	GREASE, POLYREX EM EXXON	0.085 LB
HW4032A01	BLACK DRAIN PLUG FOR WASH DOWN MOTORS	3.000 EA
09FN3001D01SP	EXTERNAL FAN, PLASTIC	1.000 EA
HW2500A25	WOODRUFF KEY USA #1008 #BLOW CARBON STEE	1.000 EA
51XB1214A20	12-14X1.25 HXWSSLD SERTYB	1.000 EA
MG1025W01	PAINT- 781-01 WILKOFASST WHITE EPOXY	0.050 GA
85XU0407S04	4X1/4 U DRIVE PIN STAINLESS	2.000 EA
LB1164	LABEL,WARNING AND DRAIN	1.000 EA
LB5040	INSTRUCTION TAG, AC & DC	1.000 EA
LB1119	WARNING LABEL	1.000 EA
LB1125C02	SUPER-E (STOCK CTN LABEL SUPER-E WITH FL	4.000 EA
LB1357	ENERGY GUIDE LABEL (BOX LABEL)	1.000 SH
LC0006	CONNECTION LABEL	1.000 EA
NP1669E	SS WD SUPER-E UL CSA CC REV MTG	1.000 EA
40PA1000	PACKAGING GROUP	1.000 EA

Performance Data at 575V, 60Hz, 20.0HP (Typical performance - Not guaranteed values)

General Characteristics							
Full Load Torque:	60.0 LB-FT			Start Configuration:	DOL		
No-Load Current:	6.62 Amps			Break-Down Torque:	189.0 LB-FT		
Line-line Res. @ 25°C.:	0.668 Ohms A Ph / 0.0 Ohms B Ph			Pull-Up Torque:	77.4 LB-FT		
Temp. Rise @ Rated Load:	71 C			Locked-Rotor Torque:	118.0 LB-FT		
Temp. Rise @ S.F. Load:	87 C			Starting Current:	134.0 Amps		
Load Characteristics							
% of Rated Load	25	50	75	100	125	150	S.F.
Power Factor:	54.0	75.0	83.0	85.0	89.0	89.0	87.0
Efficiency:	89.7	93.0	93.5	93.2	92.4	91.4	92.7
Speed:	1791.0	1784.0	1776.0	1767.0	1757.0	1747.0	1761.0
Line Amperes:	7.97	10.9	14.6	19.0	23.0	27.7	21.4

Performance Graph at 575V, 60Hz, 20.0HP Typical performance - Not guaranteed values

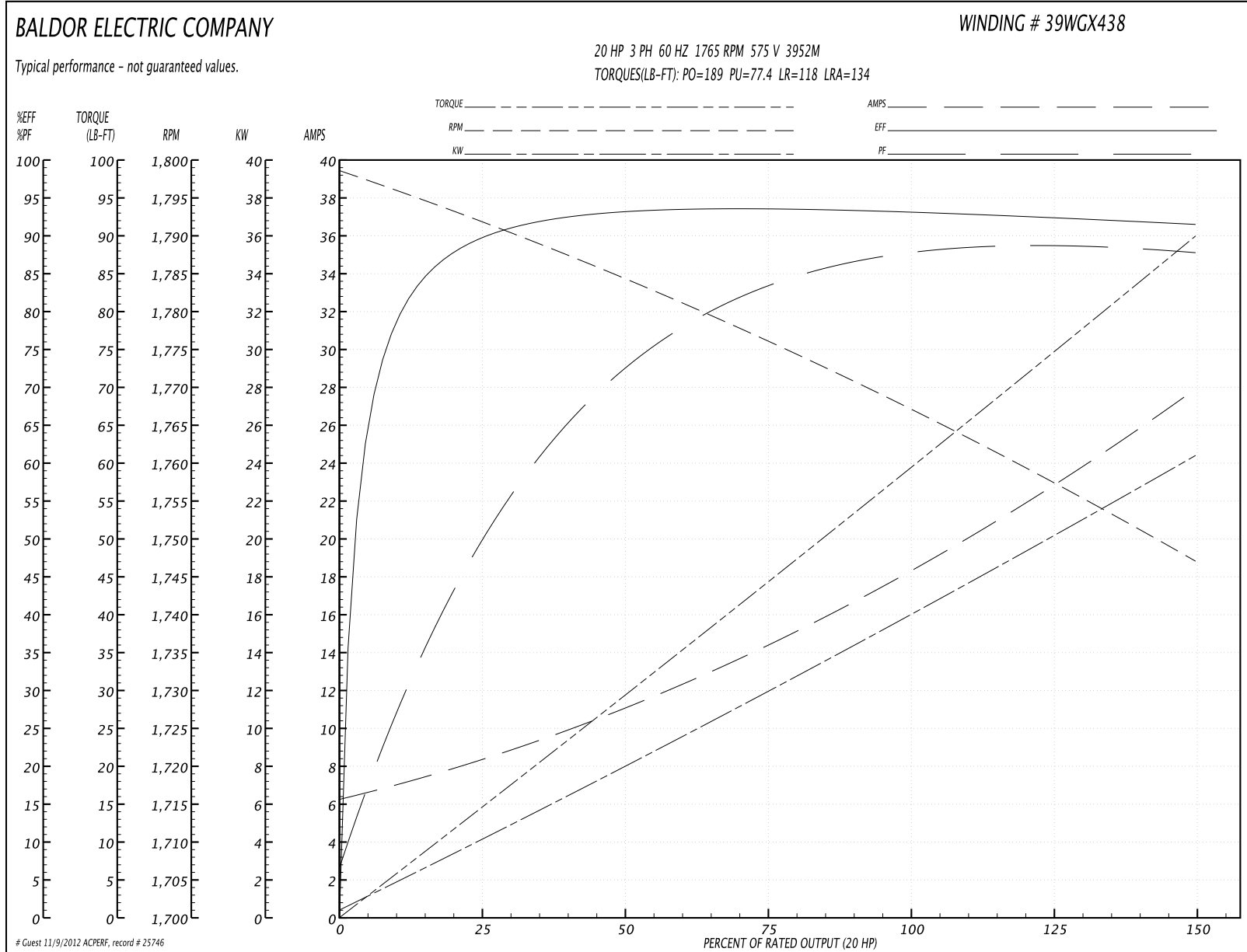

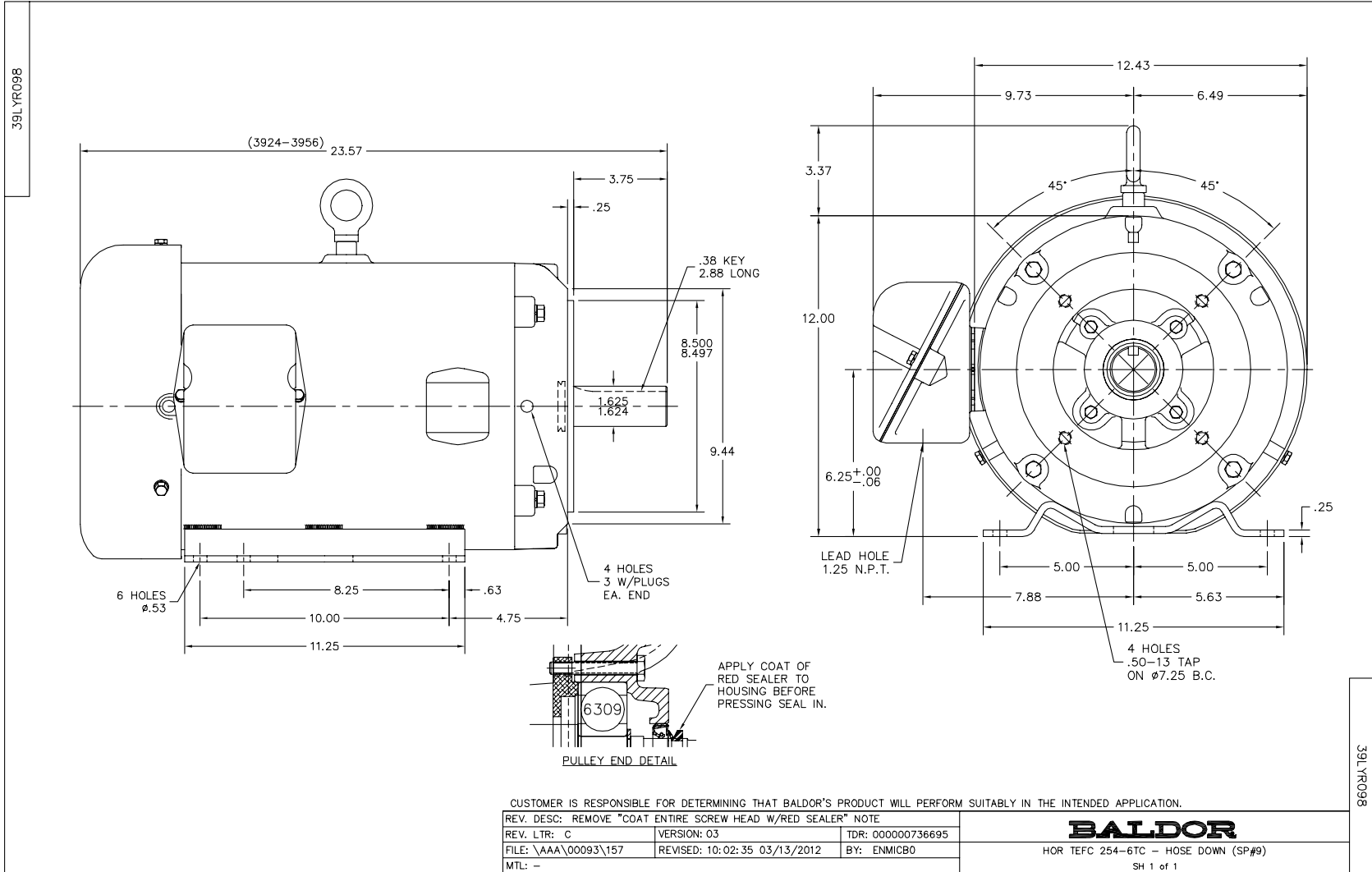

CD0006

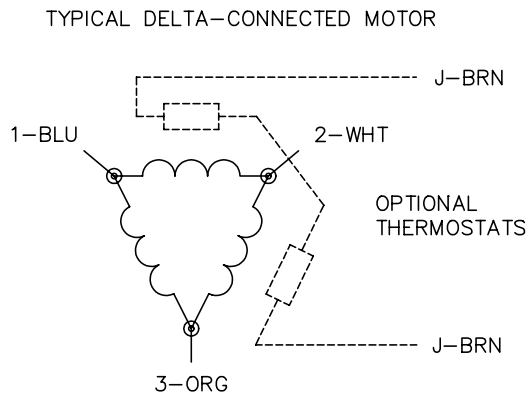
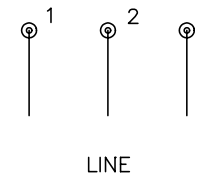
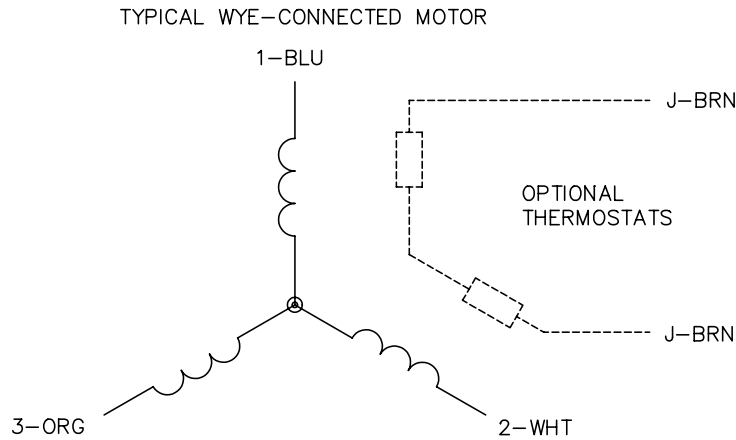

NOTES:

1. THREE LEAD MOTOR MAY BE EITHER WYE CONNECTED OR DELTA CONNECTED.
2. INTERCHANGE ANY TWO LINE LEADS TO REVERSE ROTATION.
3. OPTIONAL THERMOSTATS ARE PROVIDED WHEN SPECIFIED.
4. ACTUAL NUMBER OF INTERNAL PARALLEL CIRCUITS MAY VARY.
5. LEAD COLORS ARE OPTIONAL. LEADS MUST BE NUMBERED AS SHOWN.

REV. DESC: REVISE TO SHOW OPTIONAL COLORS			
REV. LTR: D	BY: JLP	REVISED: 01/21/99 4:02	TDR: 0171435
9000D		FILE: AAA00005141	MDL: -
		MTL: -	

BALDOR ELECTRIC Co.

3PH, SV, 3 LEADS, WYE OR DELTA CONNECTED

CD0006