

BALDOR® • *RELIANCE*

Product Information Packet

CEWDM3711T

10HP,3490RPM,3PH,60HZ,215TC,3729M,TEFC,F

Copyright © All product information within this document is subject to Baldor Electric Company copyright © protection, unless otherwise noted.

Part Detail							
Revision:	D	Status:	PRD/A	Change #:		Proprietary:	No
Type:	AC	Prod. Type:	3729M	Elec. Spec:	37WGS864	CD Diagram:	
Enclosure:	TEFC	Mfg Plant:		Mech. Spec:	37H887	Layout:	
Frame:	215TC	Mounting:	F1	Poles:	02	Created Date:	12-29-2010
Base:	RG	Rotation:	R	Insulation:	F	Eff. Date:	09-17-2012
Leads:	9#14	Literature:		Elec. Diagram:		Replaced By:	

Nameplate NP1669L									
CAT.NO.	CEWDM3711T								
SPEC.	37H887S864G1								
HP	10								
VOLTS	208-230/460								
AMP	24.9-23.6/11.8								
RPM	3490								
FRAME	215TC	HZ	60	PH	3				
SER.F.	1.15	CODE	G	DES	B	CLASS	F		
NEMA-NOM-EFF	90.2	PF	87						
RATING	40C AMB-CONT								
CC	010A	USABLE AT 208V							
DE	6307	ODE	6206						
ENCL	TEFC	SN							
BLANK									

Parts List		
Part Number	Description	Quantity
SA214691	SA 37H887S864G1	1.000 EA
RA201893	RA 37H887S864G1	1.000 EA
36FN3000C02	EXFN, PLASTIC, 5.25 OD, 1.175 ID	1.000 EA
S/P107-000-001	SUPER E PROC'S-FS & WS PLTS-POLYREX EM G	1.000 EA
HW3200A01	3/8-16X3/4 I-BLT WELDED F/S	1.000 EA
37CB3005A04W	CASTING W/.75 NPT@6(MACH WHITE)	1.000 EA
37GS1015	GASKET, FOR 37 WD KOBX'S (SANTOPRENE)	1.000 EA
51XW2520A12	.25-20 X .75, TAPTITE II, HEX WSHR SLTD	2.000 EA
11XW1032G06	10-32 X .38, TAPTITE II, HEX WSHR SLTD U	1.000 EA
37EP3101A94MW	FRONT TEFC L&M 206 BRG W/O GR SR (WHITE)	1.000 EA
HW4032A01	BLACK DRAIN PLUG FOR WASH DOWN MOTORS	3.000 EA
HW5100A06	W2420-025 WVY WSHR (WB)	1.000 EA
37EP3300A23MW	WHITE EPOXY EP MACH COMPL	1.000 EA
HW4032A01	BLACK DRAIN PLUG FOR WASH DOWN MOTORS	3.000 EA
HW4600B51SP	SEAL 1.375 X 2.125 X 0.313 SINGLE LIP DB	1.000 EA
10XN2520S30	1/4-20 X 1 7/8 HEX HEAD SS	4.000 EA
XY3118S12	5/16-18 HEX NUT, STAINLESS STEEL	4.000 EA
07FH4011	WASHDOWN IEC FH W/AUTOPHORETIC PRIMER	1.000 EA
11XW1032S06	SCREW, HXWSHR HD SLDTYF 410 SS	3.000 EA
HA1005A02SP	SLINGER, OD 2.00, ID 1.14, 206 BRG,	1.000 EA
HW4600B31SP	V-RING SLINGER #V38A,1.42/1.50 SH BORE	1.000 EA
37CB4512	CONDUIT BOX LID FOR WASHDOWN 37 FRAME	1.000 EA
37GS1008A02	37 GS FOR CB LID - WHITE NEOPRENE	1.000 EA
59XW0832S07	TAPTITE II,HEX WSHR UNSLTD SER,410 S.S.,	4.000 EA

Parts List (continued)		
Part Number	Description	Quantity
HW2502F21	#303 SS,SQ KEY 5/16 X 2.375	1.000 EA
HA7000A02	KEY RETAINER RING, 1 1/8 DIA, 1 3/8 DIA	1.000 EA
MJ5001A01	46-665 RED SEALER	0.001 QT
85XU0407S04	4X1/4 U DRIVE PIN STAINLESS	2.000 EA
LB1115	LABEL,LIFTING DEVICE	1.000 EA
LB1164	LABEL,WARNING AND DRAIN	1.000 EA
MJ1000A75	GREASE, POLYREX EM EXXON	0.050 LB
51XB1214A20	12-14X1.25 HXWSSLD SERTYB	1.000 EA
MG1025Z20	ACTIVATOR WILKOFAS 060.32	0.010 GA
MG1025W11	PAINT- 781-101 WILKOFAS WHITE EPOXY	0.028 GA
HA3104S14	300UBOLT 12.125LG SS	4.000 EA
LB1125C02	SUPER-E (STOCK CTN LABEL SUPER-E WITH FL	1.000 EA
LB1357	ENERGY GUIDE LABEL (BOX LABEL)	1.000 SH
LC0005	CONN.DIA.,TY M,9-LD,DUAL VOLT,REVERSING	1.000 EA
NP1669L	SS WD SUPER-E UL CSA-EEV PREM REV MTG	1.000 EA
G0PA1000	PACKAGING GROUP	1.000 EA

Performance Data at 460V, 60Hz, 10.0HP (Typical performance - Not guaranteed values)

General Characteristics							
Full Load Torque:	15.0 LB-FT			Start Configuration:	DOL		
No-Load Current:	4.17 Amps			Break-Down Torque:	47.2 LB-FT		
Line-line Res. @ 25°C.:	0.972 Ohms A Ph / 0.0 Ohms B Ph			Pull-Up Torque:	22.6 LB-FT		
Temp. Rise @ Rated Load:	78 C			Locked-Rotor Torque:	26.2 LB-FT		
Temp. Rise @ S.F. Load:	96 C			Starting Current:	78.5 Amps		
Load Characteristics							
% of Rated Load	25	50	75	100	125	150	S.F.
Power Factor:	53.0	74.0	84.0	87.0	89.0	89.0	88.0
Efficiency:	86.8	91.0	91.3	90.8	89.4	87.7	90.0
Speed:	3576.0	3549.0	3518.0	3486.0	3450.0	3408.0	3464.0
Line Amperes:	4.98	6.87	9.13	11.8	14.7	17.9	13.5

Performance Graph at 460V, 60Hz, 10.0HP Typical performance - Not guaranteed values

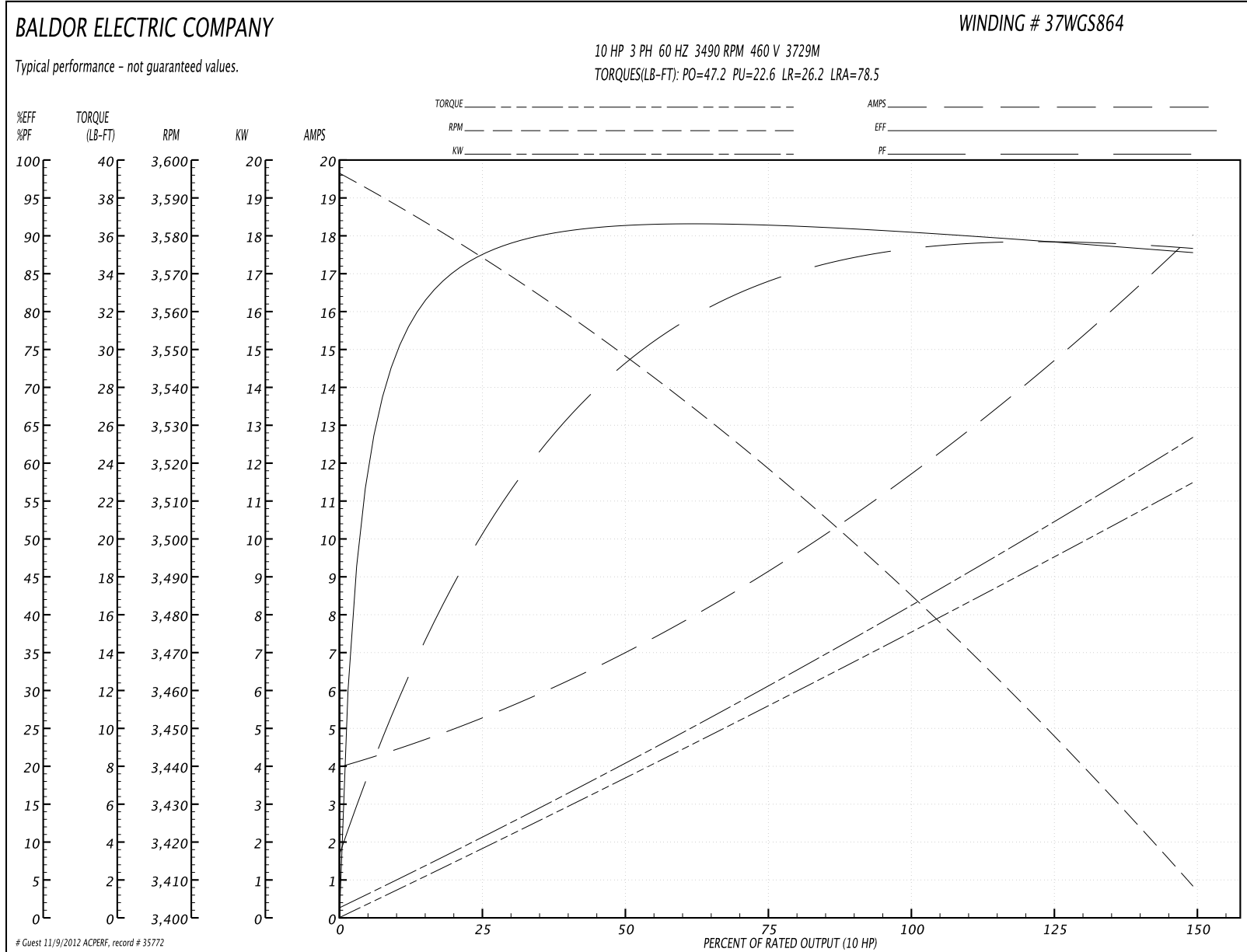

37LY1H887

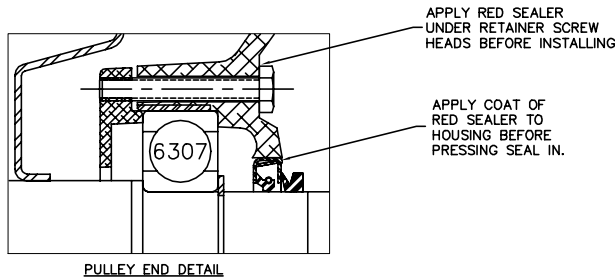
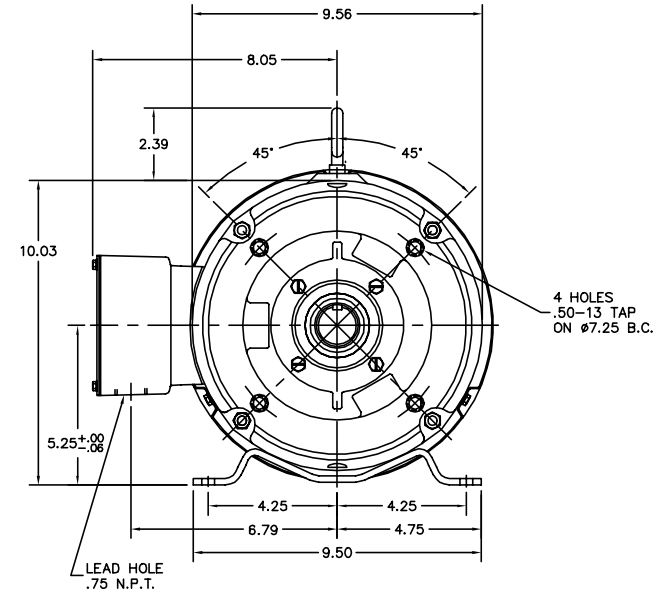
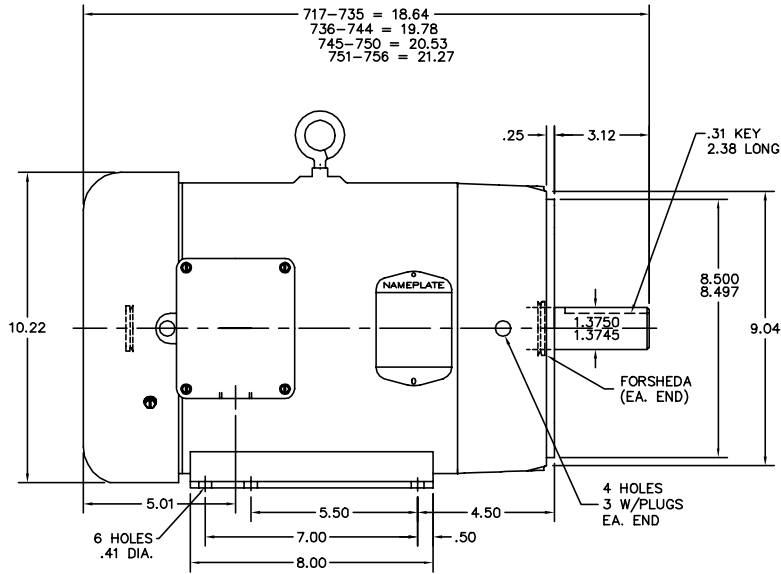

CUSTOMER IS RESPONSIBLE FOR DETERMINING THAT MOTOR PERFORMANCE IS SUITABLE IN THE APPLICATION.

REV. DESC: ADDED DRAIN PLUGS		
REV. LTR: A	VERSION: 01	TDR: 000000374458
FILE: \AAA\00093\297	REVISED: 08:38:56 08/26/2005	BY: ENKENTO
MTL: -		

BALDOR ELECTRIC Co.

STD HORZ 213-5TC TEFC 37M WD

37LY1H887

CD0005



LOW VOLTAGE
(2Y)



LINE

HIGH VOLTAGE
(1Y)

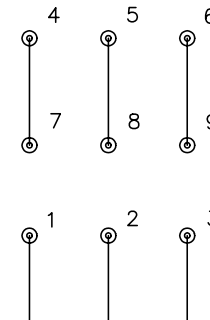

LINE

NOTES:

1. INTERCHANGE ANY TWO LINE LEADS TO REVERSE ROTATION.
2. OPTIONAL THERMOSTATS ARE PROVIDED WHEN SPECIFIED.
3. ACTUAL NUMBER OF INTERNAL PARALLEL CIRCUITS MAY BE A MULTIPLE OF THOSE SHOWN ABOVE.
4. LEAD COLORS ARE OPTIONAL. LEADS MUST ALWAYS BE NUMBERED AS SHOWN.

REV. DESC: REVISE TO SHOW OPTIONAL COLORS			
REV. LTR: E	BY: JLP	REVISED: 01/19/99 10:15	TDR: 0171435
90000		FILE: AAA00005140	MDL: -
		MTL: -	

BALDOR ELECTRIC Co.

3PH, DV, 9 LEADS

CD0005