

# **BALDOR® • RELIANCE**

## **Product Information Packet**

# **D2007R**

**7.5 1750 5 DPG C1811ATZ**

Copyright © All product information within this document is subject to Baldor Electric Company copyright © protection, unless otherwise noted.

Part Detail			
Type:	DC	Prod. Type:	TR
Power Code:	D-50/60	Weight:	197
Frame Group:	C 1811ATZ	Mounting Pos.:	F1
HP:	7.5	Enclosure:	DPG
RPM:	1750/2300	Wound:	STAB SHUNT
Service Factor:	1.0	Arm V:	240
Arm A:	28.00	Field V:	150
Field A:	1.95	Field A Hot:	1.38/.77
Insulation Class:	F	Ambient:	40
Duty:	CONT	DE Bearing:	40BC02J30X
ODE Bearing:	30BC02J30X	Brushes:	419904-51AD
Brush Qty.:			

609980-001

### INDUSTRIAL DIRECT CURRENT MOTORS AND GENERATORS - RPM III

ENCLOSURE: DRIP-PROOF FULLY-GUARDED  
SPLASHPROOF, TOTALLY ENCLOSED

MOUNTING: FOOT  
METHOD OF DRIVE: COUPLED OR BELTED

COOLING: SELF-VENTILATED  
NON-VENTILATED

ACCESSORIES: PROVISION FOR  
TACHOMETER MOUNTING  
ONLY WHEN SPECIFIED

**FRAMES C180ATZ**

DIMENSIONS ARE IN INCHES

FRAME	A	BK (1)	E	G	H	J	D	P	T	BA	K	FK	BK
C1811ATZ-C1812ATZ	9.00	4.50	3.75	.31	1.44	1.50	8.88	8.75	1.88	2.75	4.38	4.38	1.50

FRAME	C (8)	B	BS	2F	N	N-W	LK (2)	V	R (4)	SD	LGTH	FN	FN-FW	FUC (2)	FV	FR (4)	SD	LGTH	LBS.
C1811ATZ	23.94	14.00	11.00	12.50	3.00	2.75	1.3750	2.50	1.201	.312	1.75	2.44	2.25	1.1250	2.00	.986	2.50	1.38	175
C1812ATZ	25.44	15.50	12.50	14.00	3.00	2.75	1.3750	2.50	1.201	.312	1.75	2.44	2.25	1.1250	2.00	.986	2.50	1.38	175

FRAME	MAX AMPS	AA (5)	AB	AC	AF	X	Y	PART NUMBER	ONE SIZE LARGER PART NUMBER
C180ATZ	40	3/4 & 1"	7.31	5.75	1.94	4.38	5.00	705028-1-R	1-1/4 & 1-1/2
	96	1-1/4 & 1-1/2	8.31	6.31	2.50	5.00	6.12	705029-1-R	2" & 2-1/2"

FRAME	MAX AMPS	AA (6)	AB	AC	AF	X	Y	PART NUMBER	ONE SIZE LARGER PART NUMBER
C180ATZ	18	3/4	9.38	7.38	2.50	5.00	5.75	705028-2-S	1
	40	1	9.38	7.38	2.50	5.00	5.75	705028-2-T	1-1/2
	96	1-1/2	10.31	7.88	3.00	6.00	7.00	705029-2-R	2

(1) 'B' DIMENSION WILL NOT BE EXCEEDED. SHIMS UP TO .03 INCHES IN THICKNESS ARE USUALLY REQUIRED FOR COUPLED OR GEARED MACHINES.

(2) 'U' AND 'FU' VARY +.0000 - .0005

(3) TERMINAL BOX CAN BE ROTATED FOR LEAD OUTLET AT TOP, SIDES OR BOTTOM.

(4) 'R' AND 'FR' VARY +.0000 - .015

(5) AA CONDUIT. TERMINAL BOX PROVIDED WITH DOUBLE KNOCKOUT.

(6) AA PIPE TAP

(7) OPPOSITE DRIVE END SHAFT SUPPLIED ONLY WHEN SPECIFIED.

(8) WHEN THE MOTOR APPLICATION DOES NOT REQUIRE THE USE OF OPP. DRIVE END, ADD .25 TO 'C' DIM. FOR BRACKET COVER.

TERMINAL BOX LOCATED ON OPPOSITE SIDE WHEN F-2, W-1, W-4, W-5, W-7 OR C-1 MOUNTING IS SPECIFIED. BOX LOCATED ON TOP WHEN SPECIFIED.

MOTOR WEIGHT MAY VARY 15% FOR NON-STANDARD RATINGS AND/OR ACCESSORIES.

IF MOUNTING CLEARANCE DETAILS ARE REQUIRED, CONSULT FACTORY.

CUSTOMER IS RESPONSIBLE FOR DETERMINING THAT BALDOR'S PRODUCT WILL PERFORM SUITABLY IN THE INTENDED APPLICATION.

REV. DESC: LOADED TO BUS	VERSION: 00	TDR: 000000577407
REV. LTR: -	REVISED: 01:47:13 01/26/2011	BY: CONNAS
MTL: -		

DIMENSION DRAWING, C180ATZ, DPP, TENV, FOOT MTG.

SH 1 of 1

100-066600

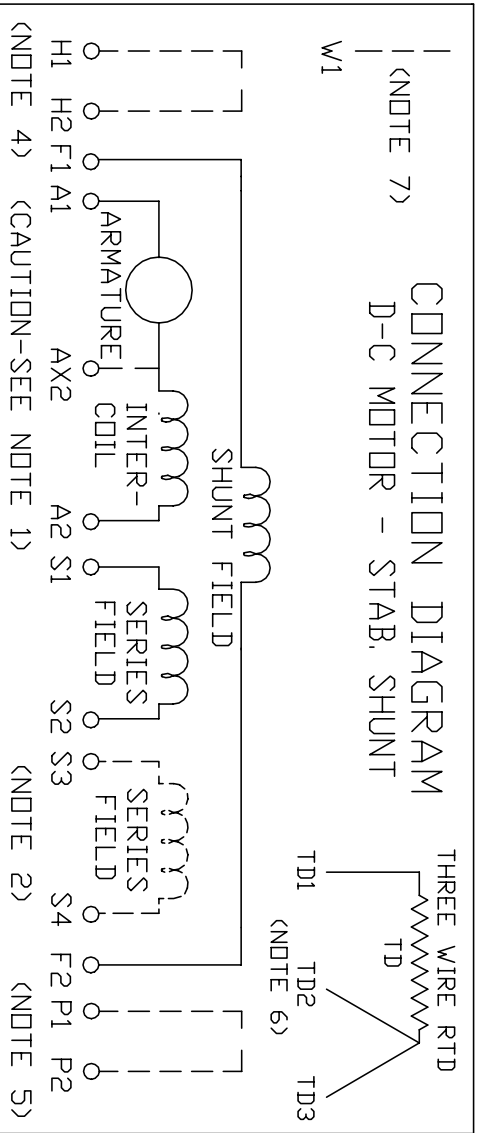

ARMATURE AND FIELD EXTERNAL CONNECTIONS  
WARNING- SEE NOTE 8 FOR GROUNDING INSTRUCTIONS



ROTATION FACING COMMUTATOR END

1. **CAUTION** — ARMATURE AND SERIES FIELD MAY HAVE MULTIPLE LEADS. CONNECT ALL LUGS WITH THE SAME MARKING TOGETHER.
2. OPTIONAL SERIES FIELD IS MARKED S3 AND S4. FOR CUMULATIVE SERIES FIELD, CONNECT S3 TO S2 AND CONNECT S4 TO NEGATIVE. FOR DIFFERENTIAL SERIES FIELD CONNECT S4 TO S2 AND S3 TO NEGATIVE.
3. OPTIONAL CONTROL SIGNAL LEAD IS MARKED AX2. ALWAYS TAKE INTERPOLE DROP BETWEEN A2 AND AX2. NOTE: NEMA DESIGNATION FOR AX2 IS LETTER C.
4. SPACE HEATERS, WHEN PROVIDED, WILL HAVE LEADS MARKED H1 AND H2, H3, H4, ETC.
5. THERMAL PROTECTOR, WHEN PROVIDED, WILL HAVE LEADS MARKED P1 AND P2, P3, P4, ETC.
6. WINDING RTDS, WHEN PROVIDED, WILL HAVE LEADS MARKED TD1, TD2, & TD3
7. BRUSH WEAR SENSOR, WHEN PROVIDED, WILL HAVE LEAD MARKED W1.
8. **WARNING** — MOTOR MUST BE GROUNDED TO PREVENT SERIOUS INJURIES TO PERSONNEL. GROUND THE MOTOR PER IEC, NATIONAL ELECTRICAL CODE AND ANY APPLICABLE LOCAL ELECTRICAL CODES. A TAPPED HOLE IS PROVIDED IN THE CONDUIT BOX, ON THE FOOT. FRAME BRACE OR OPPOSITE OPPOSITE DRIVE END BRACKET, ADJACENT TO THE TERMINAL BOX FOR FOR MOTOR GROUNDING. GROUND LEAD, WHEN PROVIDED, WILL BE GREEN.

CUSTOMER \_\_\_\_\_ RELIANCE  
ORDER NO. \_\_\_\_\_ S.D. NO. \_\_\_\_\_

<p><b>RELIANCE ELECTRIC</b> CLEVELAND, OHIO 44117 U.S.A.</p>	<p>Rev. by <u>N.L. EVANS</u> Ck. by <u>N. JESCHKE</u> App. by <u>E. L. HINER</u> DATE <u>5-5-69</u></p>
<p>CONNECTION DIAGRAM</p>	<p>406770-1</p>
<p>ORIGINAL AT RCC</p>	

C/R 290048, 354478, 354480



REL S.O.	FRAME	RATING	RPM	ARM. VOLTS	ARM. AMPS
	B1811AT	7.50HP	1750	240	28.0
WINDING TYPE		S.F.	ENCL.	AMB °C/INSUL	DUTY
STAB. SHUNT		1.0	DRG	40/F	CONT
					150
POWER CODE	TYPE	WK <sup>2</sup> (LB-FT <sup>2</sup> )	HOT ARM.CIR.RES.	FLD. AMPS@25 °C	HOT FIELD RES
D	TR	.6800	1.15	1.95	1.07

ARM. CIR. IND. (mh)	FIELD IND. (H)	COOLING AIR(CFM/IN H 20)	TURNS PER COIL SHUNT/SERIES	TEST DATE
11.5	6.76	-/-	1200/13	-

LOAD PERFORMANCE					
LOAD	AMPERES	TORQUE IN LB.-FT.	OUTPUT IN HP	RPM	% EFFICIENCY
NO LOAD	.66	0	0	2089	0
1/4	7.0	5.11	1.95	2010	75.4
2/4	14	10.7	3.95	1939	81.3
3/4	21	16.2	5.78	1879	81.3
4/4	28	21.4	7.45	1831	79.5
O.L.	42	30.9	10.3	1748	74.1

RPM VS. FIELD AMPS			Eg VS. FIELD AMPS		
FIELD AMPS	RPM N.L.	RPM F.L.	Eg N.L. @ BASE SPEED	Eg F.L. @ BASE SPEED	
1.39	2089	1831	199	177	
1.22	2140	1924	194	164	
1.05	2249	2053	185	147	
.880	2458	2235	170	128	
.708	2827	2500	148	107	

REMARKS: TYPICAL DATA

	DR. BY B. D. GRANT	<b>D-C MOTOR PERFORMANCE DATA</b> DG2032F ISSUE DATE 09/18/79
	CK. BY B. D. GRANT	
	APP. BY T. S. EVON DATE 09/18/79	

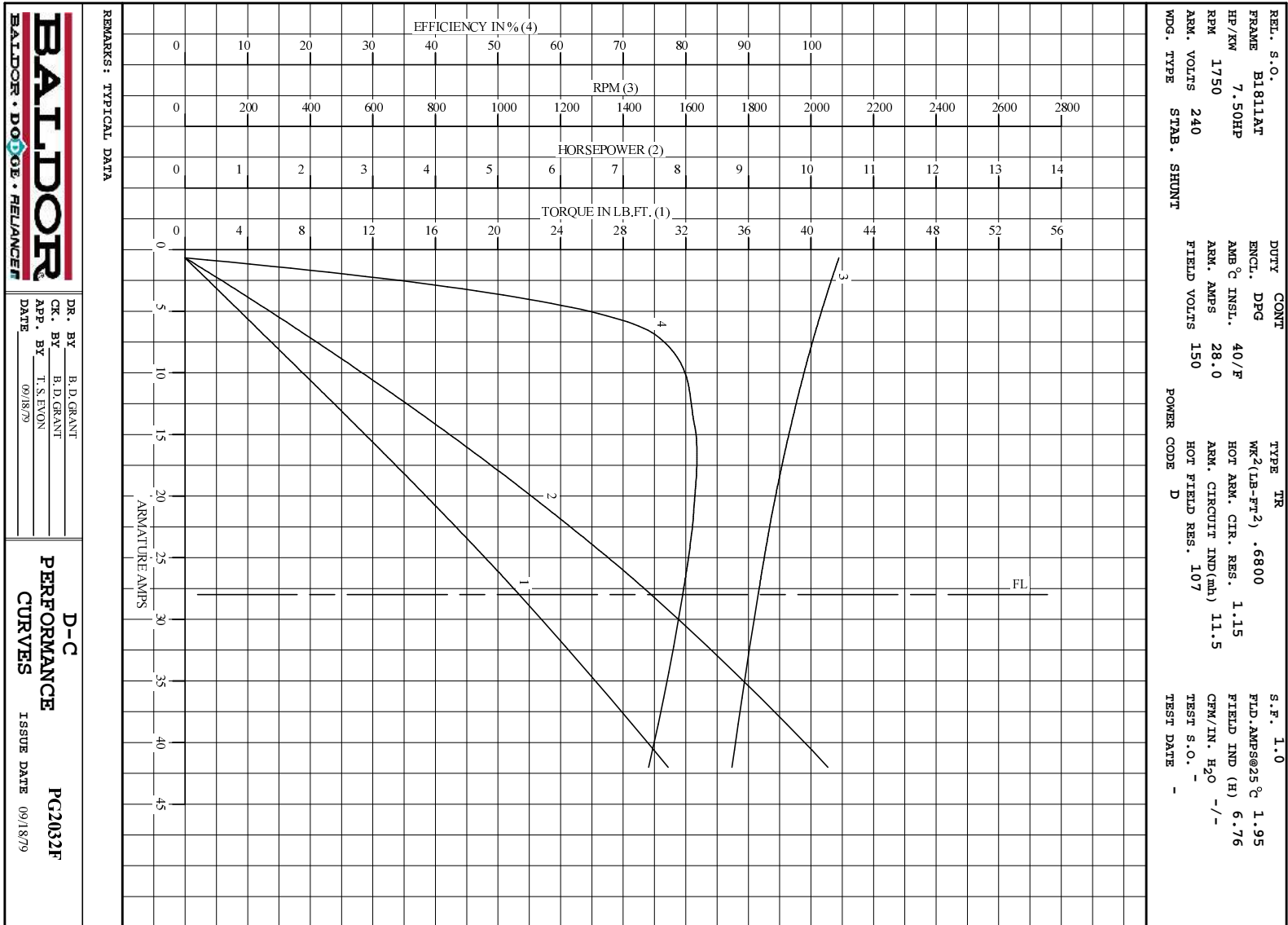

**BALDOR**  
BALDOR • DOUG • RELIANCE

DR. BY B.D. GRANT  
 CK. BY B.D. GRANT  
 APP. BY T.S. EVON  
 DATE 09/18/79

**D-C**  
**PERFORMANCE**  
**CURVES** ISSUE DATE 09/18/79  
**PG2032F**