

BALDOR® • RELIANCE

Product Information Packet

D2301

.33HP,1750RPM,DC,56,3513D,TEFC,F1

Copyright © All product information within this document is subject to Baldor Electric Company copyright © protection, unless otherwise noted.

Part Detail							
Revision:	N	Status:	PRD/A	Change #:		Proprietary:	No
Type:	DC	Prod. Type:		Elec. Spec:	35WGZ393	CD Diagram:	
Enclosure:	TEFC	Mfg Plant:		Mech. Spec:	35P316	Layout:	
Frame:	56	Mounting:	F1	Poles:	2///	Created Date:	
Base:	RG	Rotation:	R	Insulation:	F	Eff. Date:	01-31-2007
Field Type:	Compound/stab Shunt	Literature:		Elec. Diagram:		Replaced By:	

Nameplate NP0111L			
CAT.NO.	D2301		
SPEC.	35P316Z393		
HP	.33	ENCL	TEFC
RPM	1750		
FRAME	56	TYPE	CP3513D
ARM V	230	ARM A	1.7
FLD V		FLD A	
INSUL	F	AMB.	40C
DUTY	CONT	SUPPLY	A
BRG/DE	6205	BRG/ODE	6203
BRUSHES	2/BP5000T15		
		BLANK	
SER.			
BLANK			
APRV-CSA		APRV-UL	

Parts List		
Part Number	Description	Quantity
SA046562	SA 35P316Z393	1.000 EA
AA005340	AA 35P316Z393	1.000 EA
MH2001A01B19	GLASTIC SHEET .093 X 1.188 X	0.047 LB
BP5000T15SP	CARBON BRUSH-35P,180VOLTS	1.000 EA
11XW1032G06	10-32 X .38, TAPTITE II, HEX WSHR SLTD U	1.000 EA
HW3001B01	003SS CUP WASHER, FOR #8 SCREW	1.000 EA
35EP3105A01	FR ENDPLATE, MACH	1.000 EA
HW5100A03SP	WAVY WASHER (W1543-017)	1.000 EA
35EP3101A48	SPL PU EP 205 BRG LOCKED BEARING	1.000 EA
51XN1032A20	10-32 X 1 1/4 HX WS SL SR	2.000 EA
BP5201A14SP	BRUSH HOLDER ASSY	1.000 EA
80XN1032A03	10-32 X 3/16 SET SCREW	2.000 EA
MJ5004A05	#242-21 LOCTITE GENERAL PURPOSE MED. STR	0.001 EA
35FN3002A05SP	EXFN, PLASTIC, 6.376 OD, .638 ID	1.000 EA
51XB1214A16	12-14X1.00 HXWSSLD SERTYB	1.000 EA
35FH4005A04	IEC FH NO GRSR W/1.09 SHAFT HOLE, W/ AUT	1.000 EA
11XT1032A06	10-32 X 3/8 HX WSHR HD SLTD TYPE 23	3.000 EA
35CB4504	COND. BOX LID 35 DC & PM FRAMES, STAMPED	1.000 EA
35GS1008	GASKET, CONDUIT BOX LID -- 1/16 LEXIDE #	1.000 EA
51XW0832A07	8-32 X .44, TAPTITE II, HEX WSHR SLTD SE	2.000 EA
HW2501D13SP	KEY, 3/16 SQ X 1.375	1.000 EA
HA7000A04	KEY RETAINER 0.625 DIA SHAFTS	1.000 EA
WD4102A06	SR-7K-2 HEYCO STRN RELIEF OR 23MP07K20 M	1.000 EA
WD4100A17	PLUG STIMPSON D4036	1.000 EA

Parts List (continued)		
Part Number	Description	Quantity
MG1000G27	PAINT- S9282E CHARCOAL GREY	0.017 GA
10XF0440S02	04-40 X 1/8 TYPE F HEX HD STAINLESS STIC	2.000 EA
HA3100A45	THRUBOLT 10-32 X 8.875	4.000 EA
LC0862	DC -- COMPOUND WOUND MOTOR CONNECTION LA	1.000 EA
LB5040	INSTRUCTION TAG, AC & DC	1.000 EA
LB1119	WARNING LABEL	1.000 EA
LB1125C01	STD (STOCK) CARTON LABEL BALDOR WITH FLA	1.000 EA
NP0111L	NP STD LASER ENGRAVED DC MOTORS, UL CSA	1.000 EA
27PA1001	PACKAGING GROUP	1.000 EA

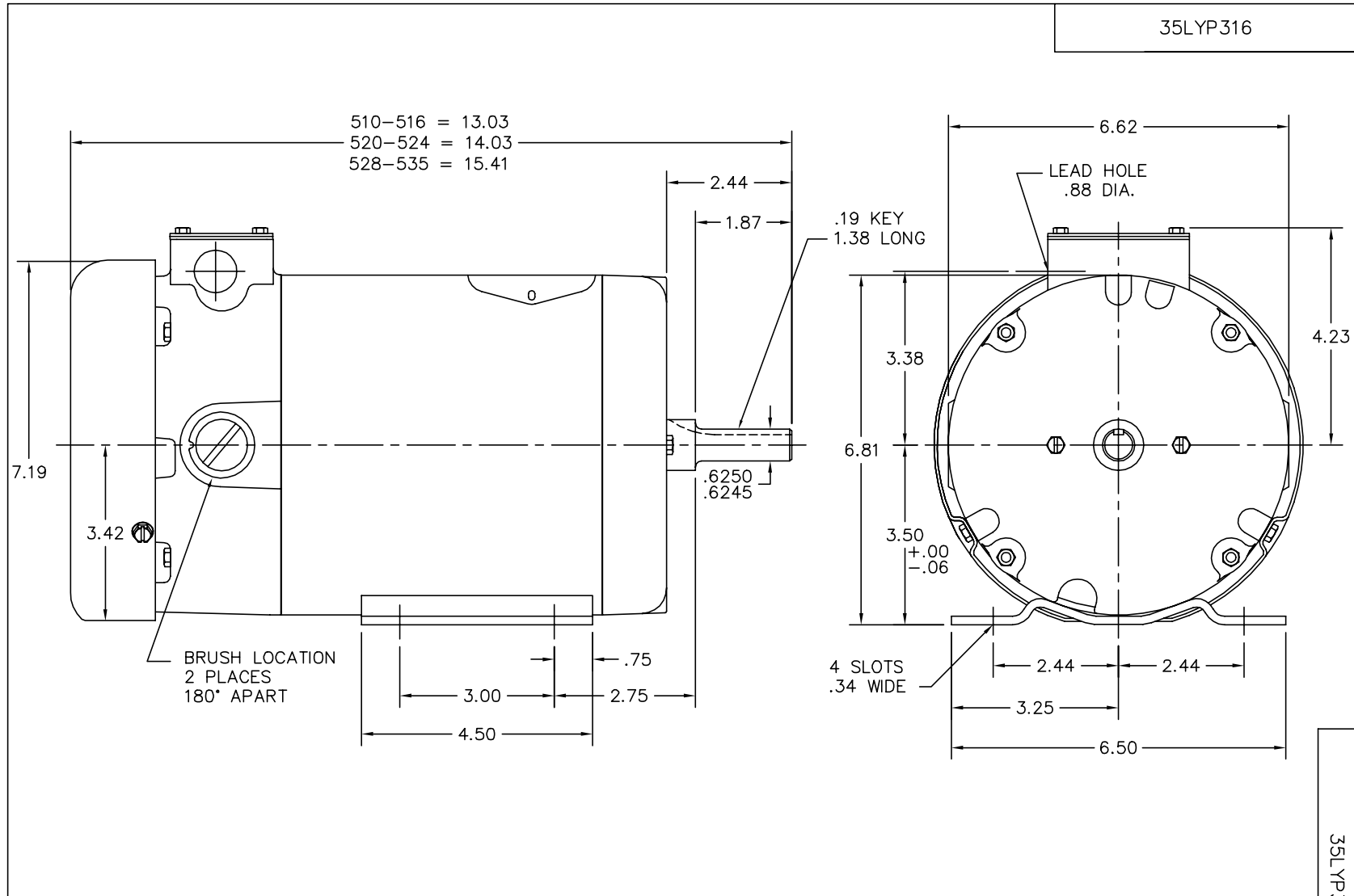

CUSTOMER IS RESPONSIBLE FOR DETERMINING THAT BALDOR'S PRODUCT WILL PERFORM SUITABLY IN THE INTENDED APPLICATION.

REV. DESC: UPDATE LAYOUT TO MATCH WITH PARTS		
REV. LTR: D	VERSION: 01	TDR: 000000751324
FILE: \AAA\00023\203	REVISED: 08: 42: 16 06/25/2012	
MTL: -	BY: ENROSTO	

BALDOR

STD HORZ 35DC NEMA 56 TEFC 2 POLE W/WELD ON BASE

SH 1 of 1

35LYP316

CD0862B01

COMPOUND WOUND

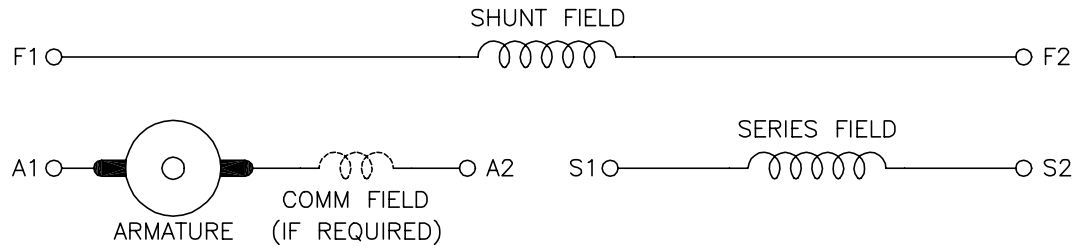

DIRECTION OF ROTATION				
CWDE		CCWDE		
POS TERM (+)	NEG TERM (-)	POS TERM (+)	NEG TERM (-)	
A1	S2	A2	S2	
F1	F2	F1	F2	
CONNECT A2 & S1		CONNECT A1 & S1		

NOTES:

1. LIMIT STARTING INRUSH CURRENT TO NOT MORE THAN 3 TIMES RATED AMPERES BY ENERGIZING THE FULL SHUNT FIELD BEFORE BRINGING THE ARMATURE VOLTAGE UP SLOWLY OR IN STEPS.
2. OPTIONAL FIELD REOSTAT MAY BE CONNECTED IN SERIES WITH THE SHUNT FIELD.
3. OPTIONAL THERMOSTAT LEADS ARE MARKED J,J.

REV. DESC: NEW, REPLACE CD0862			
REV. LTR: -	BY: JLP	REVISED: 16:10:51 11/03/2004	TDR: 347796
10BZ980DC		FILE: AAA00121482	REF: CD0862B01
CD0862B01		MTL: -	

BALDOR ELECTRIC Co.

DC CONNECTION DIAGRAM, COMPOUND FIELD, 6 LEAD

CD0862B01