

BALDOR® • RELIANCE

Product Information Packet

D2302

.5HP, 1750RPM, DC, 56, 3420D, TEFC, F1, N

Copyright © All product information within this document is subject to Baldor Electric Company copyright © protection, unless otherwise noted.

Part Detail							
Revision:	L	Status:	PRD/A	Change #:		Proprietary:	No
Type:	DC	Prod. Type:		Elec. Spec:	34WGZ512	CD Diagram:	
Enclosure:	TEFC	Mfg Plant:		Mech. Spec:	34-6121	Layout:	
Frame:	56	Mounting:	F1	Poles:	2///	Created Date:	
Base:	RG	Rotation:	R	Insulation:	F	Eff. Date:	05-30-2012
Field Type:	Compound/stab Shunt	Literature:		Elec. Diagram:		Replaced By:	

Nameplate NP0111L

CAT.NO.	D2302						
SPEC.	34-6121Z512						
HP	.5	ENCL				TEFC	
RPM	1750						
FRAME	56	TYPE				3420D	
ARM V	230	ARM A				2.1	
FLD V	230	FLD A				.24	
INSUL	F	AMB.				40	
DUTY	CONT	SUPPLY				A	
BRG/DE	6203	BRG/ODE				6203	
BRUSHES	2/BP5000H03						
					BLANK		
SER.							
BLANK	IEEE 45						
APRV-CSA					APRV-UL		

Parts List		
Part Number	Description	Quantity
SA052336	SA 34-6121Z512	1.000 EA
AA005904	AA 34-6121Z512	1.000 EA
BP5000H03SP	BRUSH ASSY, GRADE H619	1.000 EA
11XW1032G06	10-32 X .38, TAPTITE II, HEX WSHR SLTD U	1.000 EA
HW3001B01	003SS CUP WASHER, FOR #8 SCREW	1.000 EA
34EP3103A06	FR ENDPLATE MACH 34DC F-1 MTG W/.50 N.P.	1.000 EA
WD4100A17	PLUG STIMPSON D4036	1.000 EA
HW5100A03SP	WAVY WASHER (W1543-017)	1.000 EA
34EP3110A06	PU ENDPLATE, MACH	1.000 EA
HA1005A05SP	SLINGER, OD 1.50, ID .659, 203 BRG	1.000 EA
BP5201A10SP	BRUSH HOLDER ASSY W/BP4509A01 & BP3000A0	1.000 EA
80XN1032A03	10-32 X 3/16 SET SCREW	2.000 EA
34FN3002A01SP	EXTERNAL FAN, PLASTIC, .637/.639 HUB W/	1.000 EA
34FH4002A03SP	IEC FH NO GREASER W/.88 DIA SHAFT HOLE	1.000 EA
51XW1032A06	10-32 X .38, TAPTITE II, HEX WSHR SLTD S	3.000 EA
WD4100A81	CAPLUG BPF-7/8, FOR .86-.88 HOLE	1.000 EA
34CB4504SP	CONDUIT BOX LID, STAMPED	1.000 EA
34GS1014	GASKET, CONDUIT BOX LID BLACK NEOPRENE	1.000 EA
51XW0832A07	8-32 X .44, TAPTITE II, HEX WSHR SLTD SE	2.000 EA
HW2501D13SP	KEY, 3/16 SQ X 1.375	1.000 EA
HA7000A04	KEY RETAINER 0.625 DIA SHAFTS	1.000 EA
WD4102A07	STRAIN RELIEF - MICRO PLASTIC #23MP07W20	1.000 EA
MG1000G27	PAINT- S9282E CHARCOAL GREY	0.014 GA
MJ5004A05	#242-21 LOCTITE GENERAL PURPOSE MED. STR	0.001 EA

Parts List (continued)		
Part Number	Description	Quantity
MJ5001A01	46-665 RED SEALER	0.001 QT
10XF0440S02	04-40 X 1/8 TYPE F HEX HD STAINLESS STIC	2.000 EA
HA3100A12	THRUBOLT 10-32 X 7.375	4.000 EA
LB5040	INSTRUCTION TAG, AC & DC	1.000 EA
LB1119	WARNING LABEL	1.000 EA
LC0862	DC -- COMPOUND WOUND MOTOR CONNECTION LA	1.000 EA
LB1125C01	STD (STOCK) CARTON LABEL BALDOR WITH FLA	1.000 EA
NP0111L	NP STD LASER ENGRAVED DC MOTORS, UL CSA	1.000 EA
27PA1001	PACKAGING GROUP	1.000 EA

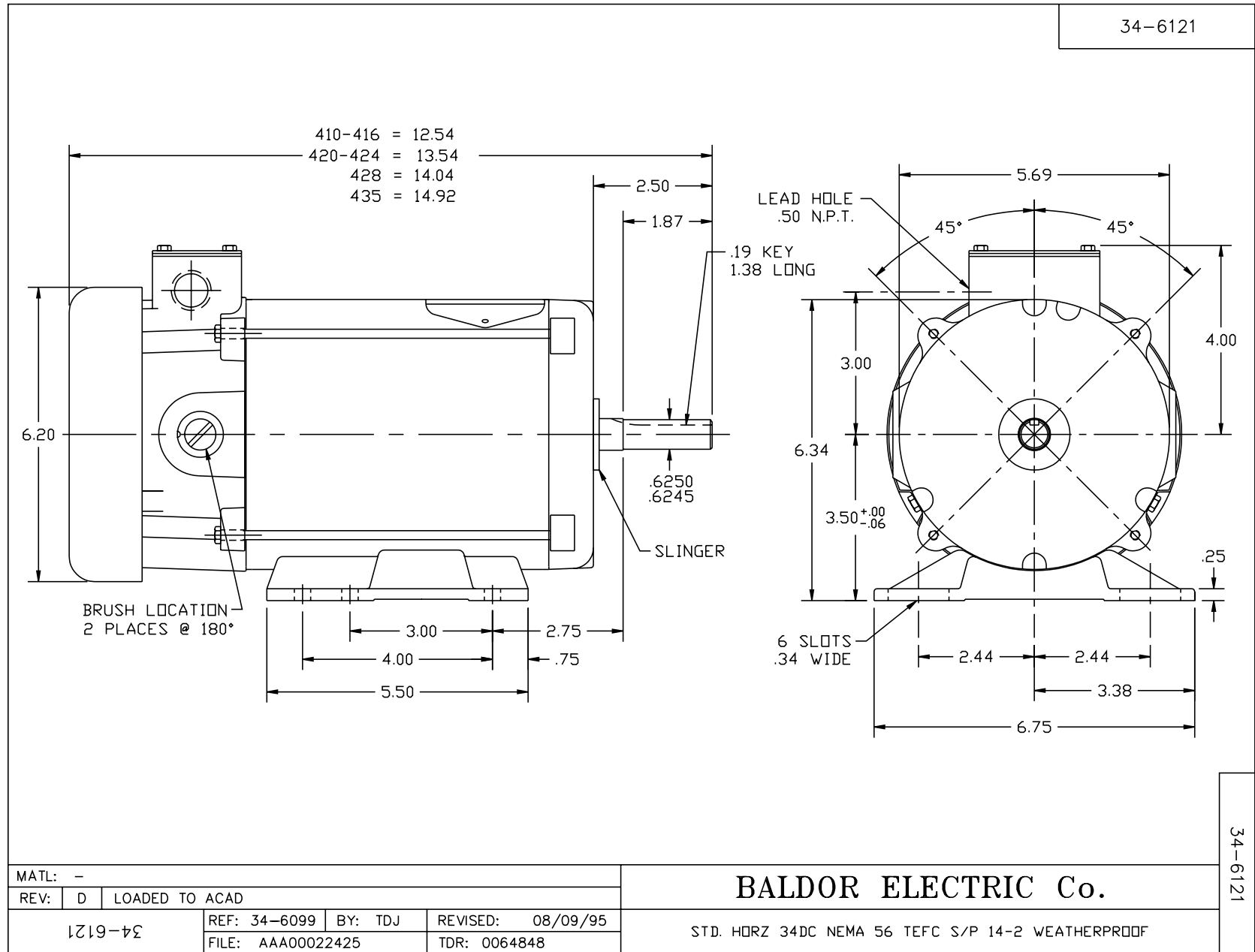

CD0862B01

COMPOUND WOUND

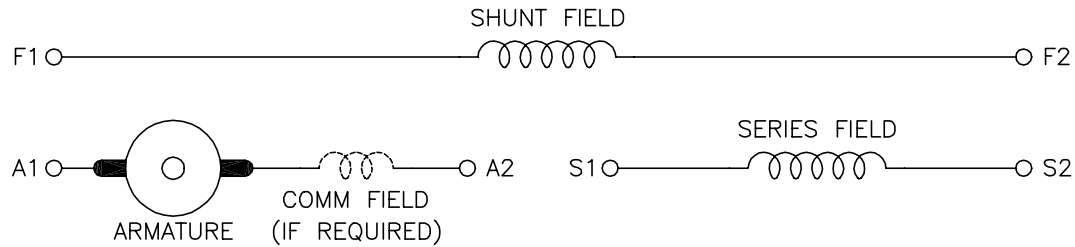

DIRECTION OF ROTATION				
CWDE		CCWDE		
POS TERM (+)	NEG TERM (-)	POS TERM (+)	NEG TERM (-)	
A1	S2	A2	S2	
F1	F2	F1	F2	
CONNECT A2 & S1		CONNECT A1 & S1		

NOTES:

1. LIMIT STARTING INRUSH CURRENT TO NOT MORE THAN 3 TIMES RATED AMPERES BY ENERGIZING THE FULL SHUNT FIELD BEFORE BRINGING THE ARMATURE VOLTAGE UP SLOWLY OR IN STEPS.
2. OPTIONAL FIELD REOSTAT MAY BE CONNECTED IN SERIES WITH THE SHUNT FIELD.
3. OPTIONAL THERMOSTAT LEADS ARE MARKED J,J.

REV. DESC: NEW, REPLACE CD0862

REV. LTR: - BY: JLP REVISED: 16:10:51 11/03/2004 TDR: 347796

10BZ980DC
CD0862B01

FILE: AAA00121482 REF: CD0862B01
MTL: -

BALDOR ELECTRIC Co.

DC CONNECTION DIAGRAM, COMPOUND FIELD, 6 LEAD

CD0862B01