

BALDOR® • *RELIANCE*

Product Information Packet

D50250RS-BV

250HP, 1750RPM, DC, 4011ATZ, DPG-FV,

Copyright © All product information within this document is subject to Baldor Electric Company copyright © protection, unless otherwise noted.

Part Detail			
Type:	DC	Prod. Type:	TR
Power Code:	C	Weight:	2310
Frame Group:	C 4011ATZ	Mounting Pos.:	F2
HP:	250	Enclosure:	DPFV
RPM:	1750/2000	Wound:	STAB SHUNT
Service Factor:	1.0	Arm V:	500
Arm A:	400.00	Field V:	300
Field A:	6.63	Field A Hot:	4.72/3.76
Insulation Class:	F	Ambient:	40
Duty:	CONT	DE Bearing:	95BC02J30X
ODE Bearing:	95BC02J30X	Brushes:	419904-52AA
Brush Qty.:			

609962-025

INDUSTRIAL DIRECT CURRENT MOTORS AND GENERATORS - RPM III

ENCLOSURE: DRIP-PROOF FULLY-GUARDED,
SPLASHPROOF
MOUNTING: FOOT

COOLING: FORCE VENTILATED WITH
INTEGRAL BLOWER AND
MOTOR AIR FILTERED-
SPECIAL BAFFLE

ACCESSORIES: PROVISION FOR
TACHOMETER MOUNTING
ONLY WHEN SPECIFIED

FRAMES C4011ATZ THRU ULC4013ATZ

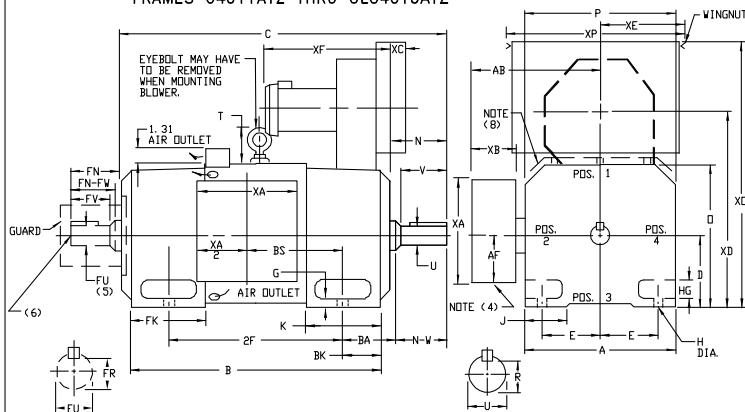

DIMENSIONS ARE IN INCHES

FRAME	A	D(1)	E	G	H	HG	J	D	P	T	BA	K	FK	BK	AB	AF	RH(6)
C4011ATZ-ULC4013ATZ	19.38	10.00	8.00	1.06	1.06	2.82	3.50	19.81	19.56	4.31	6.62	8.75	12.12	5.25	16.12	8.00	1.6240

FRAME	METHOD OF DRIVE	C(7)	B	BS	2F	DRIVE END SHAFT AND KEY						(5) OPPOSITE DRIVE END SHAFT AND KEY						WT. LBS.		
						N	N-W	UK(3)	V	RK(3)	SO	LGTH	FN	FN-FV	FK(2)	FV	FK(3)		SO	LGTH
C4011ATZ	COUPLED	52.19	42.06	16.00	28.00	7.62	7.25	3.625	7.00	3.134	875	5.75	7.62	7.25	3.625	7.00	3.134	875	5.75	2500
UC4011ATZ	BELTED	53.19	42.06	16.00	28.00	8.62	8.25	4.125	8.00	3.563	1.000	6.50	7.62	7.25	3.625	7.00	3.134	875	5.75	2505
MC4013ATZ	COUPLED	56.94	46.81	20.75	36.00	7.62	7.25	3.625	7.00	3.134	875	5.75	7.62	7.25	3.625	7.00	3.134	875	5.75	2800
UMC4013ATZ	BELTED	57.94	46.81	20.75	36.00	8.62	8.25	4.125	8.00	3.563	1.000	6.50	7.62	7.25	3.625	7.00	3.134	875	5.75	2805
LC4013ATZ	COUPLED	60.19	50.06	24.00	36.00	7.62	7.25	3.625	7.00	3.134	875	5.75	7.62	7.25	3.625	7.00	3.134	875	5.75	3100
ULC4013ATZ	BELTED	61.19	50.06	24.00	36.00	8.62	8.25	4.125	8.00	3.563	1.000	6.50	7.62	7.25	3.625	7.00	3.134	875	5.75	3105

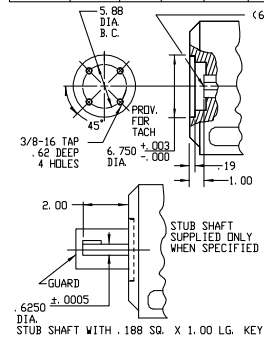

FRAME	XA	XB	XC	XD	XE	XF	XD	XP
C4011ATZ-ULC4013ATZ	16.00	6.00	1.25	26.00	9.84	18.75	42.94	22.50

- (1) "D" DIMENSION WILL NOT BE EXCEEDED. SHIMS UP TO .06 INCHES IN THICKNESS ARE USUALLY REQUIRED FOR COUPLED OR GEARED MACHINES.
- (2) "FV" AND "FV-FV" VARY ----+ .000 - .015
- (3) "R" AND "R-FV" VARY ----+ .000 - .015
- (4) CUSTOMER TO PROVIDE HOLE IN TERMINAL BOX FOR CONDUIT.
- (5) OPPOSITE DRIVE END SHAFT SUPPLIED ONLY WHEN SPECIFIED.
- (6) MOTOR SHAFT TAPPED FOR SCREW-IN STUB SHAFT
- (7) WHEN THE MOTOR APPLICATION DOES NOT REQUIRE THE USE OF DPP, DRIVE END, ADD .25 TO "C" DIM. FOR BRACKET COVER.
- (8) FOR HORIZONTAL APPLICATIONS ONLY.

CUSTOMER IS RESPONSIBLE FOR DETERMINING THAT BALDOR'S PRODUCT WILL PERFORM SUITABLY IN THE INTENDED APPLICATION.

REV. DESC: LOADED TO BUS	VERSION: 00	TDR: 000000577407
REV. LTR: -	REVISED: 12:40:55 01/26/2011	BY: CONNAS
FILE: \RGG\00015\603		
MTL: -		

BALDOR

DIMENSION DRAWING, C4011ATZ - ULC4013ATZ, DPP, FOOT MTG.

SH 1 of 1

609962-025

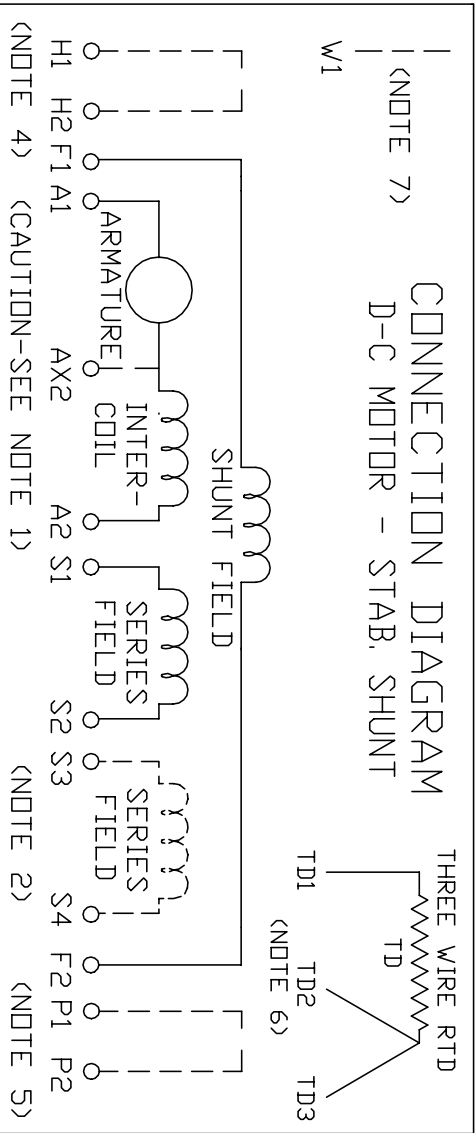

ARMATURE AND FIELD EXTERNAL CONNECTIONS
WARNING- SEE NOTE 8 FOR GROUNDING INSTRUCTIONS



ROTATION FACING COMMUTATOR END

1. **CAUTION** — ARMATURE AND SERIES FIELD MAY HAVE MULTIPLE LEADS. CONNECT ALL LUGS WITH THE SAME MARKING TOGETHER.
2. OPTIONAL SERIES FIELD IS MARKED S3 AND S4. FOR CUMULATIVE SERIES FIELD, CONNECT S3 TO S2 AND CONNECT S4 TO NEGATIVE. FOR DIFFERENTIAL SERIES FIELD CONNECT S4 TO S2 AND S3 TO NEGATIVE.
3. OPTIONAL CONTROL SIGNAL LEAD IS MARKED AX2. ALWAYS TAKE INTERPOLE DROP BETWEEN A2 AND AX2. NOTE: NEMA DESIGNATION FOR AX2 IS LETTER C.
4. SPACE HEATERS, WHEN PROVIDED, WILL HAVE LEADS MARKED H1 AND H2, H3, H4, ETC.
5. THERMAL PROTECTOR, WHEN PROVIDED, WILL HAVE LEADS MARKED P1 AND P2, P3, P4, ETC.
6. WINDING RTDS, WHEN PROVIDED, WILL HAVE LEADS MARKED TD1, TD2, & TD3
7. BRUSH WEAR SENSOR, WHEN PROVIDED, WILL HAVE LEAD MARKED W1.
8. **WARNING** — MOTOR MUST BE GROUNDED TO PREVENT SERIOUS INJURIES TO PERSONNEL. GROUND THE MOTOR PER IEC, NATIONAL ELECTRICAL CODE AND ANY APPLICABLE LOCAL ELECTRICAL CODES. A TAPPED HOLE IS PROVIDED IN THE CONDUIT BOX, ON THE FOOT. FRAME BRACE OR OPPOSITE OPPOSITE DRIVE END BRACKET, ADJACENT TO THE TERMINAL BOX FOR FOR MOTOR GROUNDING. GROUND LEAD, WHEN PROVIDED, WILL BE GREEN.

CUSTOMER _____ RELIANCE
ORDER NO. _____ S.D. NO. _____

<p style="text-align: center;">RELIANCE ELECTRIC</p> <p style="text-align: center;">CLEVELAND, OHIO 44117 U.S.A.</p>	<p style="text-align: center;">Rev. by <u>N.L. EVANS</u> Ck. by <u>N. JESCHKE</u> App. by <u>E. J. HINER</u> DATE <u>5-5-69</u></p>
<p style="text-align: center;">CONNECTION DIAGRAM</p> <p style="text-align: center; font-size: 24pt;">406770-1</p> <p style="text-align: center;">ORIGINAL AT RCC</p>	

C/R 290048, 354478, 354480

REF. S.O.	FRAME C4011ATZ	RATING 250HP	BASE SPEED 1750	WINDING TYPE STAB SHUNT
S.F. ENCL. 1.0 DPEV	AMB°C/INSUL 40/F	DUTY CONT	POWER CODE/FORM FACTOR C	TYPE TR
COOLING AIR (CFM/IN H ₂ O) 1200/4.0	R (hot) .0416	T _e .0229	T _m .0208	WR ² (LB-FT ²) 66.21
WINDING	VOLTS	RESISTANCE		TURNS PER COIL
ARM CIRCUIT	500	25°C .0321	HOT .0435	-
SERIES S1-S2	-	.00309	.00429	1.15 MH
SHUNT F1-F2	300	45.2	62.7	2.00
			6.63	23.8 H
			4.79	700

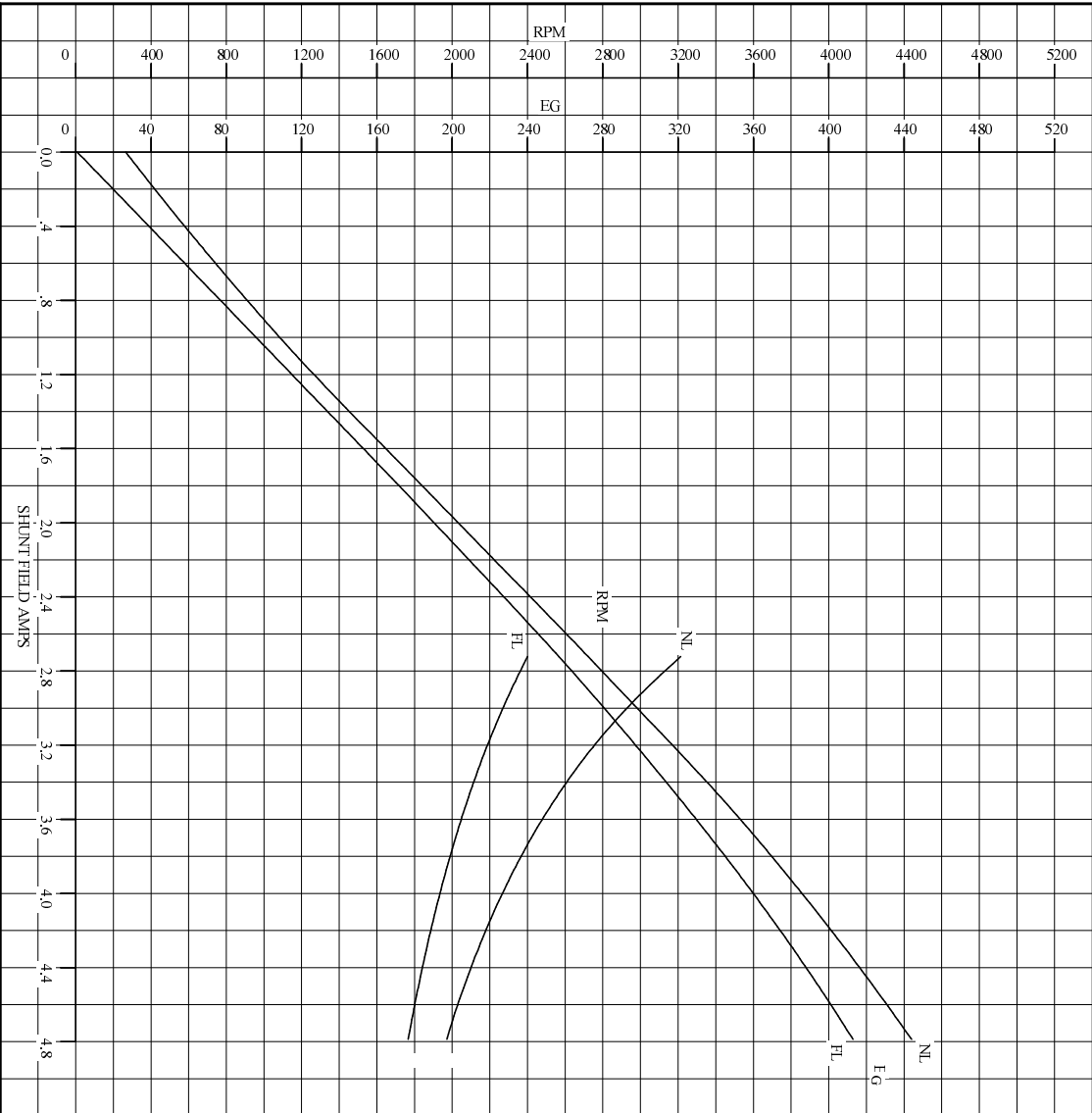

REMARKS: TYPICAL DATA
CURVES VALID FOR NAMEPLATE SPEED RANGE ONLY

BALDOR	DR. BY J. MARTIN
DOUG • RELIANCE	CK. BY R. REINACHER
	APP. BY T. EYON
	DATE 02/21/91

D-C	APPLICATION	SC7618A
DATA	ISSUE DATE	04-19-95

C/R 314413

REL S.O.	FRAME	RATING	RPM	ARM. VOLTS	ARM. AMPS
	C4011ATZ	250HP	1750	500	400
WINDING TYPE		S.F.	ENCL.	AMB °C/INSUL	DUTY
STAB. SHUNT		1.0	DPFV	40/F	CONT
					300
POWER CODE	TYPE	WK 2 (LB-PT 2)	HOT ARM. CIR. RES.	FLD. AMPS@25 °C	HOT FIELD RES
C	TR	66.21	.0434	6.63	62.6

ARM. CIR. IND. (mh)	FIELD IND. (H)	COOLING AIR (CFM/IN H 20)	TURNS PER COIL SHUNT/SERIES	TEST DATE
1.14	23.8	1200/4.0	700/2	-

LOAD PERFORMANCE

LOAD	AMPERES	TORQUE IN LB.-FT.	OUTPUT IN HP	RPM	% EFFICIENCY
NO LOAD	7.3	0	0	1956	0
1/4	100	172	61.9	1886	88.8
2/4	200	363	126	1828	92.5
3/4	300	557	189	1787	93.0
4/4	400	747	251	1765	92.7
O.L.	600	1114	369	1740	91.2

RPM VS. FIELD AMPS

FIELD AMPS	RPM N.L.	RPM F.L.	Eg N.L. @ BASE SPEED	Eg F.L. @ BASE SPEED
4.78	1955	1764	443	412
4.27	2149	1869	407	379
3.75	2390	2001	366	341
3.23	2725	2172	320	300
2.72	3214	2400	272	256

MAXIMUM SAFE SPEED = 3000 RPM

REMARKS: TYPICAL DATA

	DR. BY J. MARTIN	D-C MOTOR PERFORMANCE DATA DG7618A ISSUE DATE 04-19-95
	CK. BY R. BRACKNER	
	APP. BY T. EVON DATE 02/21/91	

C/R 314413

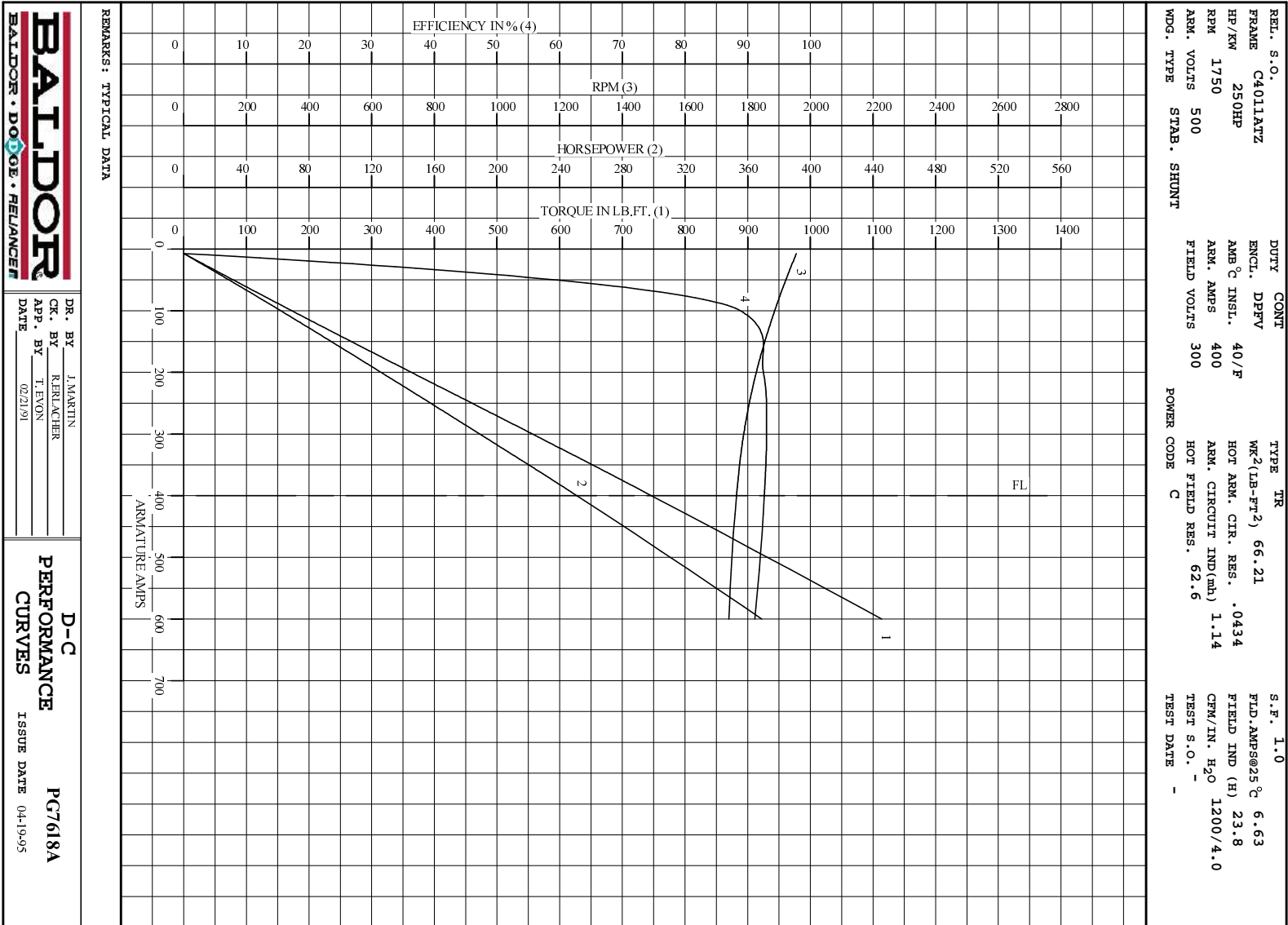

C/R 314413



DR. BY J. MARTIN
 CK. BY R. REINACHER
 APP. BY T. EYON
 DATE 02/21/91

D-C
PERFORMANCE
CURVES ISSUE DATE 04-19-95
PG7618A