

BALDOR® • RELIANCE

Product Information Packet

D5025R-BV

25HP, 1750RPM, DC, 2113ATZ, DPG-FV,

Copyright © All product information within this document is subject to Baldor Electric Company copyright © protection, unless otherwise noted.

Part Detail			
Type:	DC	Prod. Type:	TR
Power Code:	C	Weight:	370
Frame Group:	MC 2113ATZ	Mounting Pos.:	F1
HP:	25	Enclosure:	DPFV
RPM:	1750/2300	Wound:	STR SHUNT
Service Factor:	1.0	Arm V:	500
Arm A:	46.00	Field V:	300
Field A:	3.32	Field A Hot:	2.40/1.57
Insulation Class:	F	Ambient:	40
Duty:	CONT	DE Bearing:	50BC03J30X
ODE Bearing:	45BC02J30X	Brushes:	419904-51AB
Brush Qty.:			

16002-001

INDUSTRIAL DIRECT CURRENT MOTORS AND GENERATORS - RPM III

ENCLOSURE: DRIP-PROOF FULLY-GUARDED,
SPLASHPROOF

COOLING: FORCE VENTILATED
WITH INTEGRAL
BLOWER AND MOTOR

MOUNTING: FOOT
METHOD OF DRIVE: COUPLED OR BELTED

ACCESSORIES: PROVISION FOR
TACHOMETER MOUNTING
ONLY WHEN SPECIFIED

FRAMES SC2113ATZ THRU LC2115ATZ

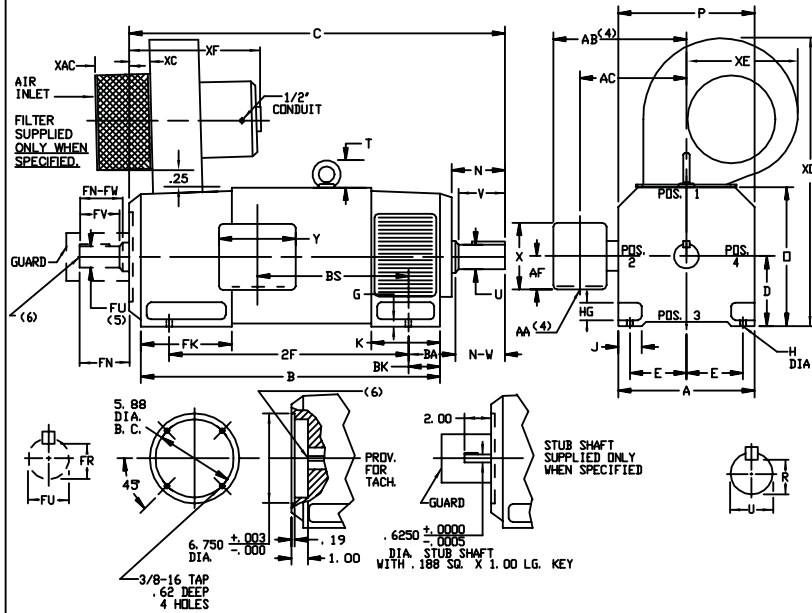

DIMENSIONS ARE IN INCHES

FRAME	XAC	XC	XE	XF	XO
SC2113ATZ-LC2115ATZ	7.75	2.25	10.00	16.00	22.75

FRAME	A	D(1)	E	G	H	HG	J	O	P	T	BA	K	FK	BK
SC2113ATZ-LC2115ATZ	10.25	5.25	4.25	.44	.44	1.38	1.75	10.44	10.31	2.08	3.50	5.19	6.81	2.38

FRAME	C(7)	B	BS	2F	DRIVE END SHAFT AND KEY					OPPOSITE DRIVE END SHAFT AND KEY(S)					VT.				
					N	N-W	U(2)	V	R(3)	SQ.	LGTH	FN	FN-FW	FU(2)		FV	FR(3)	SQ.	LGTH
SC2113ATZ	28.38	22.50	11.38	18.00	4.00	3.75	1.875	3.50	1.991	.500	2.50	3.50	3.25	1.625	3.00	1.416	.375	2.25	345
MC2113ATZ	29.62	23.75	12.62	18.00	4.00	3.75	1.875	3.50	1.991	.500	2.50	3.50	3.25	1.625	3.00	1.416	.375	2.25	370
LC2113ATZ	31.25	25.38	14.25	18.00	4.00	3.75	1.875	3.50	1.991	.500	2.50	3.50	3.25	1.625	3.00	1.416	.375	2.25	400
MC2115ATZ	32.50	26.62	15.50	22.00	4.00	3.75	1.875	3.50	1.991	.500	2.50	3.50	3.25	1.625	3.00	1.416	.375	2.25	425
LC2115ATZ	35.25	29.38	18.25	22.00	4.00	3.75	1.875	3.50	1.991	.500	2.50	3.50	3.25	1.625	3.00	1.416	.375	2.25	480

- (1) "D" DIMENSION WILL NOT BE EXCEEDED. SHIMS UP TO .03 INCHES IN THICKNESS ARE USUALLY REQUIRED FOR COUPLED OR GEARED MACHINES.
- (2) "U" AND "FU" VARY----+.000 - .001
- (3) "R" AND "FR" VARY----+.000 - .015
- (4) TERMINAL BOX VARIES WITH H.P. FOR DIMENSIONS "AA", "AB", "AC", "AF", "X" AND "Y". REFER TO BOX D/S. (STD. 609959-1, "X/P" 609959-2, MILL 609959-3)
- (5) OPPOSITE DRIVE END SHAFT SUPPLIED ONLY WHEN SPECIFIED.
- (6) MOTOR SHAFT TAPPED FOR SCREW-IN STUB SHAFT.
- (7) WHEN THE MOTOR APPLICATION DOES NOT REQUIRE THE USE OF OPP. DRIVE END, ADD .25 TO "C" DIM. FOR BRACKET COVER. TERMINAL BOX CAN BE ROTATED FOR LEAD OUTLET AT TOP, SIDES OR BOTTOM OR C-1 MOUNTING IS SPECIFIED. BOX LOCATED ON TOP WHEN SPECIFIED. BLOWER ASSEMBLY CAN BE LOCATED AT POSITIONS 1, 2, OR 4, EXCEPT BLOWER ASSEMBLY AND TERMINAL BOX CAN NOT BE LOCATED AT THE SAME POSITION. MOTOR WEIGHT MAY VARY 15% FOR NON-STANDARD RATINGS AND/OR ACCESSORIES. IF MOUNTING CLEARANCE DETAILS ARE REQUIRED, CONSULT FACTORY.

CUSTOMER IS RESPONSIBLE FOR DETERMINING THAT BALDOR'S PRODUCT WILL PERFORM SUITABLY IN THE INTENDED APPLICATION.

REV. DESC: LOADED TO BUS	VERSION: 00	TDR: 000000578087
REV. LTR: -	REVISED: 08:22:49 01/28/2011	BY: CONNAS
FILE: \RGG\00015\944		
MTL: -		

BALDOR
DIMENSION DRAWING: SC2113ATZ - LC2115ATZ, DPP, FOOT MTG
SH 1 of 1

16002-001

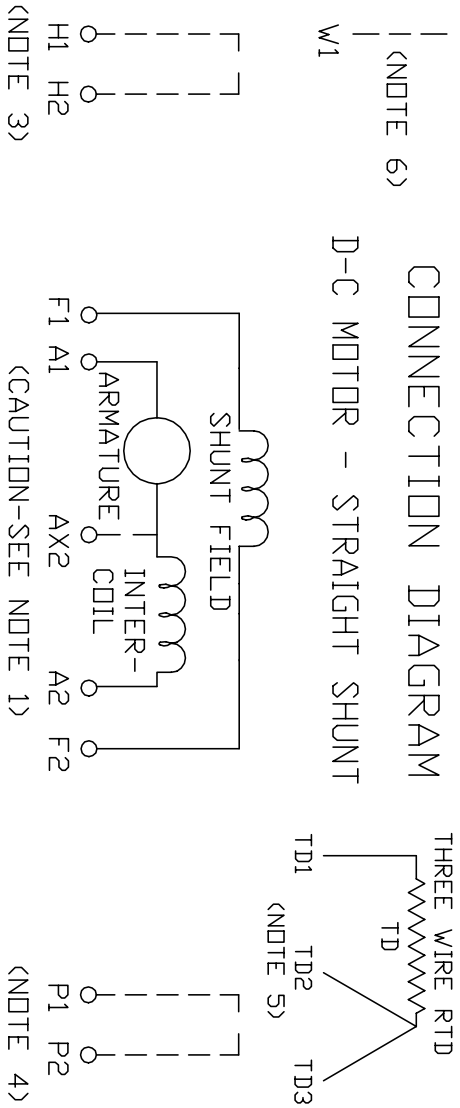

1. **CAUTION** — ARMATURE MAY HAVE MULTIPLE LEADS. CONNECT ALL LUGS WITH THE SAME MARKING TOGETHER.
2. OPTIONAL CONTROL SIGNAL LEAD IS MARKED AX2. ALWAYS TAKE INTERPOLE DROP BETWEEN A2 AND AX2. NOTE: NEMA DESIGNATION FOR AX2 IS LETTER C.
3. SPACE HEATERS, WHEN PROVIDED, WILL HAVE LEADS MARKED H1 AND H2, H3, H4, ETC.
4. THERMAL PROTECTOR, WHEN PROVIDED, WILL HAVE LEADS MARKED P1 AND P2, P3, P4, ETC.
5. WINDING RTD'S, WHEN PROVIDED, WILL HAVE LEAD MARKED W1.
6. BRUSH WEAR SENSOR, WHEN PROVIDED, WILL HAVE LEAD MARKED W1.
7. **WARNING** — MOTOR MUST BE GROUNDED TO PREVENT SERIOUS INJURIES TO PERSONNEL. GROUND THE MOTOR PER IEC, NATIONAL ELECTRICAL CODE AND ANY APPLICABLE LOCAL ELECTRICAL CODES. A TAPPED HOLE IS PROVIDED IN THE CONDUIT BOX, ON THE FOOT. FRAME BRACE OR OPPOSITE OPPOSITE DRIVE END BRACKET, ADJACENT TO THE TERMINAL BOX FOR FOR MOTOR GROUNDING. GROUND LEAD, WHEN PROVIDED, WILL BE GREEN.

CUSTOMER _____ RELIANCE _____
ORDER NO. _____ S.O. NO. _____

<p>RELIANCE ELECTRIC</p> <p>CLEVELAND, OHIO 44117 U.S.A.</p>	<p>Rev. BY N.L. EVANS CHK BY N. JESCHKE APP BY E.J. HINER DATE 5-5-69</p> <p>CONNECTION DIAGRAM</p> <p style="font-size: 24pt; font-weight: bold;">406770-6</p> <p>ORIGINAL AT RCC</p>
--	--

C/R 244907, 290048, 354478, 354480

REL. S.O.	FRAME	RATING	RPM	ARM. VOLTS	ARM. AMPS
	MC2113ATZ	25.0HP	1750	500	46.0
WINDING TYPE		S.F.	ENCL.	AMB °C/INSUL	DUTY
STRAIGHT SHUNT		1.0	DEPRV	40/F	CONT
					FIELD VOLTS
					300
POWER CODE	TYPE	WK ² (LB-FT ²)	HOT ARM. CIR. RES.	FLD. AMPS@25 °C	HOT FIELD RES
C	TR	2.564	1.43	3.33	124
ARM. CIR. IND. (mh)	FIELD IND. (H)	COOLING AIR (CFM/IN H 20)	TURNS PER COIL SHUNT/SERIES	TEST DATE	
14.6	12.0	300/2.25	950/.00000	-	
LOAD PERFORMANCE					
LOAD	AMPERES	TORQUE IN LB.-FT.	OUTPUT IN HP	RPM	% EFFICIENCY
NO LOAD	.91	0	0	1916	0
1/4	12	19.1	6.79	1868	77.6
2/4	23	39.4	13.7	1826	83.1
3/4	35	58.7	20.0	1792	82.8
4/4	46	76.7	25.8	1767	81.0
O.L.	69	108	35.7	1735	75.6
RPM VS. FIELD AMPS					
FIELD AMPS	RPM N.L.	RPM F.L.	Eg N.L. @ BASE SPEED	Eg F.L. @ BASE SPEED	
2.40	1916	1767	454	426	
2.19	1995	1861	436	405	
1.99	2091	1973	416	382	
1.78	2223	2114	392	356	
1.57	2404	2300	364	328	
REMARKS: TYPICAL DATA MAXIMUM SAFE SPEED = 4500 RPM SPEED REGULATOR REQUIRED FOR STABILITY					
RELIANCE ELECTRIC		DR. BY J. MARTIN CK. BY K. BRACKER APP. BY T. EVONN DATE 8/28/85	D-C MOTOR PERFORMANCE DATA DG6005E ISSUE DATE 08-05-97		

REL. S. O.	FRAME	MC2113ATZ	RATING	25.0HP	BASE SPEED	1750	WINDING TYPE	STRAIGHT SHUNT
S. F.	ENCL.	AMB°C/INSUL	DUTY	CONT	POWER CODE/FORM FACTOR	C	TYPE	TR
1.0	DPFV	40/F						2.564
COOLING AIR (CFM/IN H ² O) (sec)		R (hot)	T _e	T _m	BASIC RPM	MAX CONT RPM	WINDER RPM	MAX. SAFE
300/2.25		.194	.00981	.0309	1950	2300	-	4500
WINDING	VOLTS	RESISTANCE		CURRENT		INDUCTANCE	TURNS PER COIL	
ARM CIRCUIT	500	25°C	HOT	25°C	HOT			
SERIES SI-S2	-	.989	1.44	-	46.0	14.7	mH	-
SHUNT FI-F2	300	90.0	125	3.33	2.41	12.0	H	950

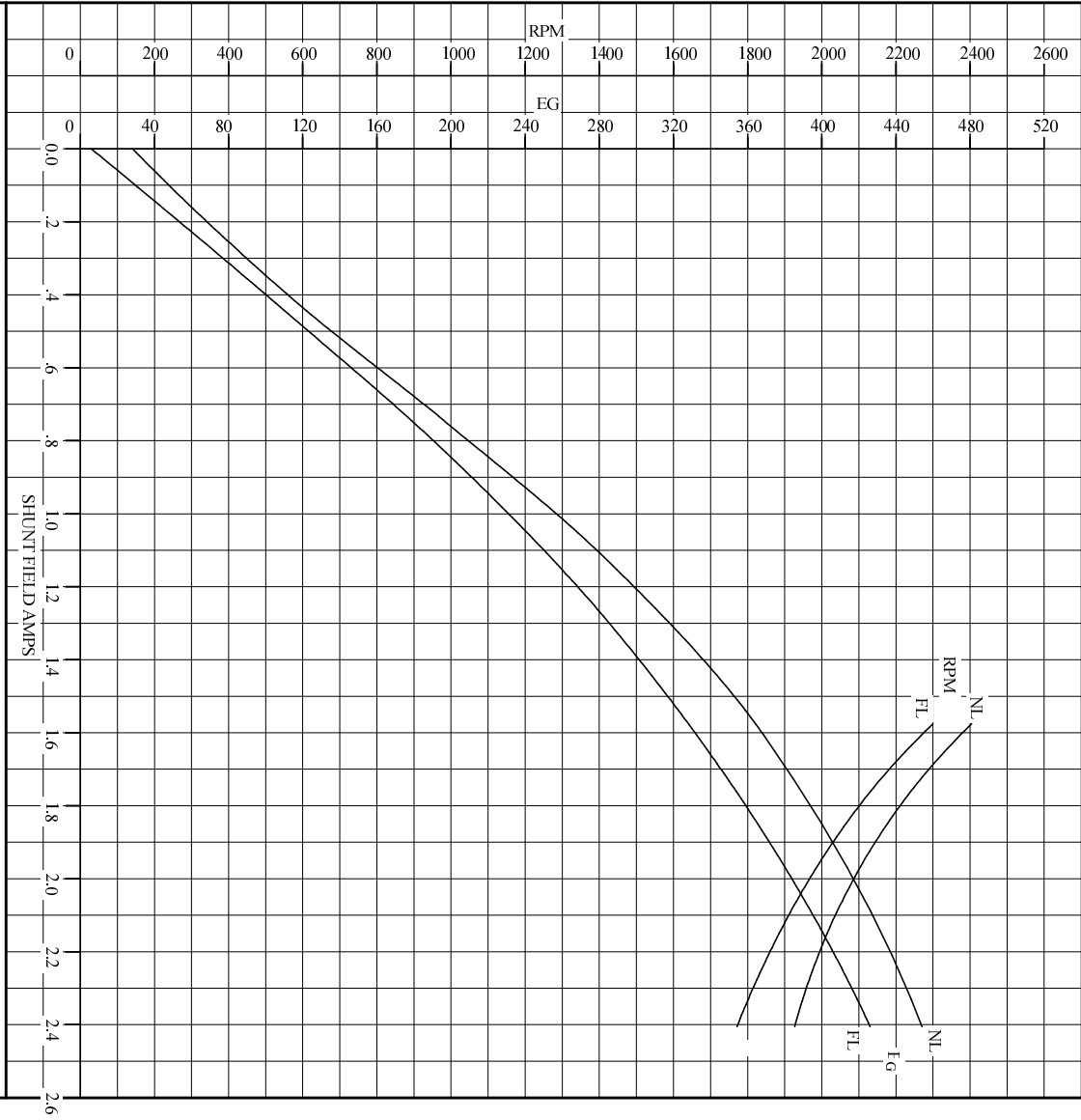

REMARKS: TYPICAL DATA SPEED REGULATOR REQUIRED FOR STABILITY
CURVES VALID FOR NAMEPLATE SPEED RANGE ONLY

	DR. BY	J. MARTIN	D-C APPLICATION DATA ISSUE DATE 08-05-97
	CR. BY	R. RACHNER	
	APP. BY	T. EVON	
	DATE	8/28/85	

