

BALDOR® • RELIANCE

Product Information Packet

D5025R

25 1750 LC2113ATZ DPG 500V

Copyright © All product information within this document is subject to Baldor Electric Company copyright © protection, unless otherwise noted.

Part Detail			
Type:	DC	Prod. Type:	TR
Power Code:	C	Weight:	394
Frame Group:	LC 2113ATZ	Mounting Pos.:	F1
HP:	25	Enclosure:	DPG
RPM:	1750/2300	Wound:	STAB SHUNT
Service Factor:	1.0	Arm V:	500
Arm A:	43.00	Field V:	300
Field A:	2.63	Field A Hot:	1.80/1.24
Insulation Class:	F	Ambient:	40
Duty:	CONT	DE Bearing:	50BC03J30X
ODE Bearing:	45BC02J30X	Brushes:	419904-51AB
Brush Qty.:			

609950-001

INDUSTRIAL DIRECT CURRENT MOTORS AND GENERATORS - RPM III

ENCLOSURE: DRIP-PROOF FULLY-GUARDED, COOLING: SELF-VENTILATED
 SPLASHPROOF, TOTALLY ENCLOSED NON-VENTILATED

MOUNTING: FOOT ACCESSORIES: PROVISION FOR TACHOMETER MOUNTING
 METHOD OF DRIVE: COUPLED OR BELTED ONLY WHEN SPECIFIED

FRAMES SC2113ATZ THRU LC2812ATZ

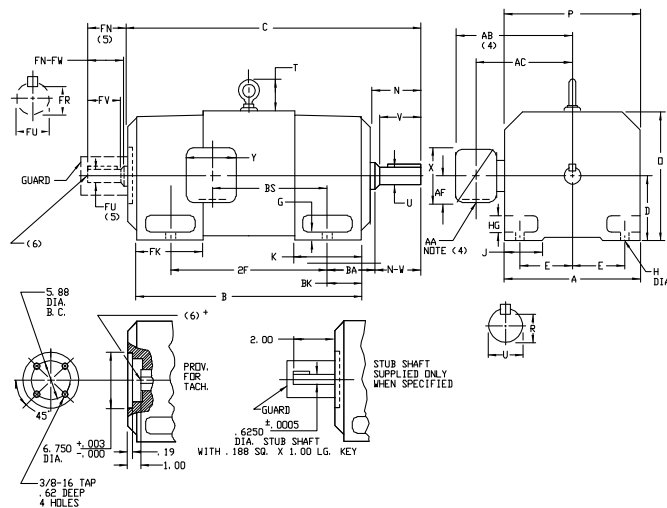

DIMENSIONS ARE IN INCHES; SEE 609950-1M FOR DIMENSIONS IN MILLIMETERS

FRAME	A	B(1)	E	G	H	HG	J	D	P	T	BA	K	FK	BK
SC2113ATZ-LC2113ATZ	10.25	5.25	4.25	.44	.44	1.38	1.75	10.44	10.31	2.56	3.50	5.19	6.81	2.38
SC2512ATZ-LC2512ATZ	12.31	6.25	5.00	.50	.56	1.62	2.00	12.50	12.44	3.06	4.25	6.06	8.00	3.00
MC2812ATZ-LC2812ATZ	13.78	7.00	5.50	.62	.56	1.88	2.75	14.00	13.94	3.38	4.75	6.75	9.19	3.50

FRAME	C(7)	B	BS	2F	DRIVE END SHAFT AND KEY							OPPOSITE DRIVE END SHAFT AND KEYS					WT. LBS.		
					N	N-W	U(2)	V	R(2)	SO	LGTH	FN	FN-FV	FK(2)	FV	FR(2)		SO	LGTH
SC2113ATZ	28.38	22.50	11.38	18.00	4.00	3.75	1.875	3.50	1.591	.500	2.50	3.50	3.25	1.625	3.00	1.416	.375	2.25	315
MC2113ATZ	29.62	23.75	12.62	18.00	4.00	3.75	1.875	3.50	1.591	.500	2.50	3.50	3.25	1.625	3.00	1.416	.375	2.25	340
LC2113ATZ	31.25	25.38	14.25	18.00	4.00	3.75	1.875	3.50	1.591	.500	2.50	3.50	3.25	1.625	3.00	1.416	.375	2.25	370
SC2512ATZ	31.69	25.06	12.06	20.00	4.50	4.25	2.125	4.00	1.845	.500	3.00	4.00	3.75	1.875	3.50	1.591	.500	2.50	525
MC2512ATZ	33.19	26.56	13.56	20.00	4.50	4.25	2.125	4.00	1.845	.500	3.00	4.00	3.75	1.875	3.50	1.591	.500	2.50	540
LC2512ATZ	34.69	28.06	15.06	20.00	4.50	4.25	2.125	4.00	1.845	.500	3.00	4.00	3.75	1.875	3.50	1.591	.500	2.50	580
MC2812ATZ	37.38	29.94	14.25	22.00	5.00	4.75	2.375	4.50	2.021	.625	3.50	4.50	4.25	2.125	4.00	1.845	.500	3.00	775
LC2812ATZ	39.62	32.19	16.50	22.00	5.00	4.75	2.375	4.50	2.021	.625	3.50	4.50	4.25	2.125	4.00	1.845	.500	3.00	850

- (1) "B" DIMENSION WILL NOT BE EXCEEDED. SHIMS UP TO .03 INCHES IN THICKNESS ARE USUALLY REQUIRED FOR COUPLED OR GEARED MACHINES.
 - (2) "U" AND "FU" VARY---.000 ---.001
 - (3) "R" AND "FR" VARY---.000 ---.015
 - (4) TERMINAL BOX VARIES WITH N.P. FOR DIMENSIONS "AA", "AB", "AC", "AF", "X" AND "Y". REFER TO BOX D/S. CSTR. 609950-1. *APP. 609950-2. MILL. 609950-3
 - (5) OPPOSITE DRIVE END SHAFT SUPPLIED ONLY WHEN SPECIFIED.
 - (6) MOTOR SHAFT TAPPED FOR SCREW IN STUB SHAFT.
 - (7) WHEN THE MOTOR APPLICATION DOES NOT REQUIRE THE USE OF DPG, DRIVE END, ADD .25 TO "C" DIM. FOR BRACKET COVER.
- TERMINAL BOX CAN BE ROTATED FOR LEAD OUTLET AT TOP, SIDES OR BOTTOM. TERMINAL BOX LOCATED ON OPPOSITE SIDE WHEN F-2, V-1, W-4, V-5, V-7, OR C-1 MOUNTING IS SPECIFIED. BOX LOCATED ON TOP WHEN SPECIFIED. MOTOR WEIGHT MAY VARY 15% FOR NON-STANDARD RATINGS AND/OR ACCESSORIES. IF MOUNTING CLEARANCE DETAILS ARE REQUIRED, CONSULT FACTORY.

CUSTOMER IS RESPONSIBLE FOR DETERMINING THAT BALDOR'S PRODUCT WILL PERFORM SUITABLY IN THE INTENDED APPLICATION.

REV. DESC: LOADED TO BUS	VERSION: 00	TDR: 00000577407
REV. LTR: -	REVISED: 10.21.19 01/26/2011	BY: RGGBG
FILE: \RGG\00015\543		
MTL: -		

BALDOR

DIMENSION DRAWING, SC2113ATZ - LC2812ATZ, DPG, TENV, FOOT MTG

SH 1 of 1

100-056609

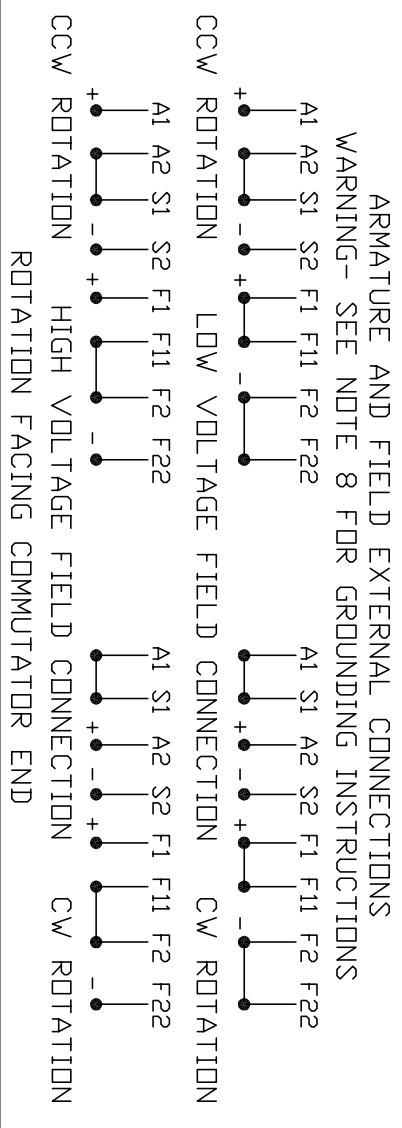
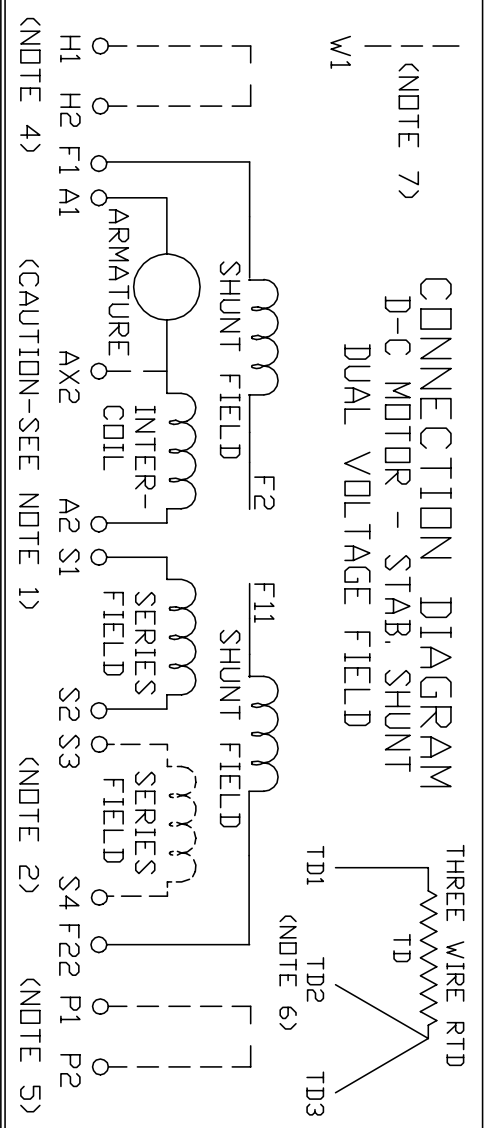

1. **CAUTION** — ARMATURE AND SERIES FIELD MAY HAVE MULTIPLE LEADS. CONNECT ALL LUGS WITH THE SAME MARKING TOGETHER.
2. OPTIONAL SERIES FIELD IS MARKED S3 AND S4. FOR CUMULATIVE SERIES FIELD, CONNECT S3 TO S2 AND CONNECT S4 TO NEGATIVE. FOR DIFFERENTIAL SERIES FIELD CONNECT S4 TO S2 AND S3 TO NEGATIVE.
3. OPTIONAL CONTROL SIGNAL LEAD IS MARKED AX2. ALWAYS TAKE INTERPOLE DROP BETWEEN A2 AND AX2. NOTE: NEMA DESIGNATION FOR AX2 IS LETTER C.
4. SPACE HEATERS, WHEN PROVIDED, WILL HAVE LEADS MARKED H1 AND H2, H3, H4, ETC.
5. THERMAL PROTECTOR, WHEN PROVIDED, WILL HAVE LEADS MARKED P1 AND P2, P3, P4, ETC.
6. WINDING RTDS, WHEN PROVIDED, WILL HAVE LEADS MARKED TD1, TD2, & TD3
7. BRUSH WEAR SENSOR, WHEN PROVIDED, WILL HAVE LEAD MARKED W1.
8. **WARNING** — MOTOR MUST BE GROUNDED TO PREVENT SERIOUS INJURIES TO PERSONNEL. GROUND THE MOTOR PER IEC, NATIONAL ELECTRICAL CODE AND ANY APPLICABLE LOCAL ELECTRICAL CODES. A TAPPED HOLE IS PROVIDED IN THE CONDUIT BOX, ON THE FOOT. FRAME BRACE OR OPPOSITE OPPOSITE DRIVE END BRACKET, ADJACENT TO THE TERMINAL BOX FOR FOR MOTOR GROUNDING. GROUND LEAD, WHEN PROVIDED, WILL BE GREEN.

CUSTOMER _____ RELIANCE _____
 ORDER NO. _____ S.D. NO. _____

RELIANCE ELECTRIC CLEVELAND, OHIO 44117 U.S.A.	DR. BY: N.L. EVANS CK. BY: N. JESCHKE APP. BY: E. J. HINER DATE: 5-5-69
CONNECTION DIAGRAM	406770-2 ORIGINAL AT RRC

C/R 244907, 290048, 354478, 354480

REL. S.O.	FRAME	RATING	RPM	ARM. VOLTS	ARM. AMPS
	LC2113AT	25.0HP	1750	500	43.0
WINDING TYPE		S.F.	ENCL.	AMB °C/INSUL	DUTY
STAB. SHUNT		1.0	DPG	40/F	CONT
					300
POWER CODE	TYPE	WK ² (LB-FT ²)	HOT ARM. CIR. RES.	FLD. AMPS@25 °C	HOT FIELD RES
C	TR	2.868	1.05	2.61	1.65
ARM. CIR. IND. (mh)	FIELD IND. (H)	COOLING AIR (CFM/IN H 20)	TURNS PER COIL SHUNT/SERIES	TEST DATE	
12.4	18.2	-/-	950/4	-	
LOAD PERFORMANCE					
LOAD	AMPERES	TORQUE IN LB.-FT.	OUTPUT IN HP	RPM	% EFFICIENCY
NO LOAD	1.6	0	0	2040	0
1/4	11	15.8	5.99	1991	74.6
2/4	22	34.2	12.7	1945	83.1
3/4	32	52.2	19.0	1908	84.5
4/4	43	69.6	24.9	1878	84.0
O.L.	65	102	35.7	1835	80.9
RPM VS. FIELD AMPS			Eg VS. FIELD AMPS		
FIELD AMPS	RPM N.L.	RPM F.L.	Eg N.L. @ BASE SPEED	Eg F.L. @ BASE SPEED	
1.81	2040	1878	426	398	
1.67	2140	1959	407	379	
1.53	2252	2053	387	359	
1.39	2394	2164	364	337	
1.25	2575	2300	339	313	
REMARKS: TYPICAL DATA MAXIMUM SAFE SPEED = 4500 RPM					
RELIANCE ELECTRIC		DR. BY <u>B. D. GRANT</u> CK. BY <u>B. D. GRANT</u> APP. BY <u>T. S. EVON</u> DATE <u>06/10/85</u>		D-C MOTOR PERFORMANCE DATA D66061B ISSUE DATE 06/06/85	

REL. S. O.	FRAME LC2113AT	RATING 25.0HP	BASE SPEED 1750	WINDING TYPE STAB SHUNT
S. F. ENCL. 1.0 DPG	AMB°C/INSUL 40/F	DUTY CONT	POWER CODE/FORM FACTOR C	TYPE TR
COOLING AIR (CFM/IN H ² O) -/-	\bar{R} (sec) .217	T_R .105	T_M .10229	WINDER RPM MAX. SAFE 4500
WINDING ARM CIRCUIT SERIES S1-S2 SHUNT F1-F2	VOLTS	RESISTANCE		CURRENT
		25°C .720	HOT 1.05	25°C 43.0
		.0311	.0443	HOT 43.0
		115	1.65	2.62
				INDUCTANCE 12.5 mH
				TURN'S PER COIL - 4.00
				18.2 H 950

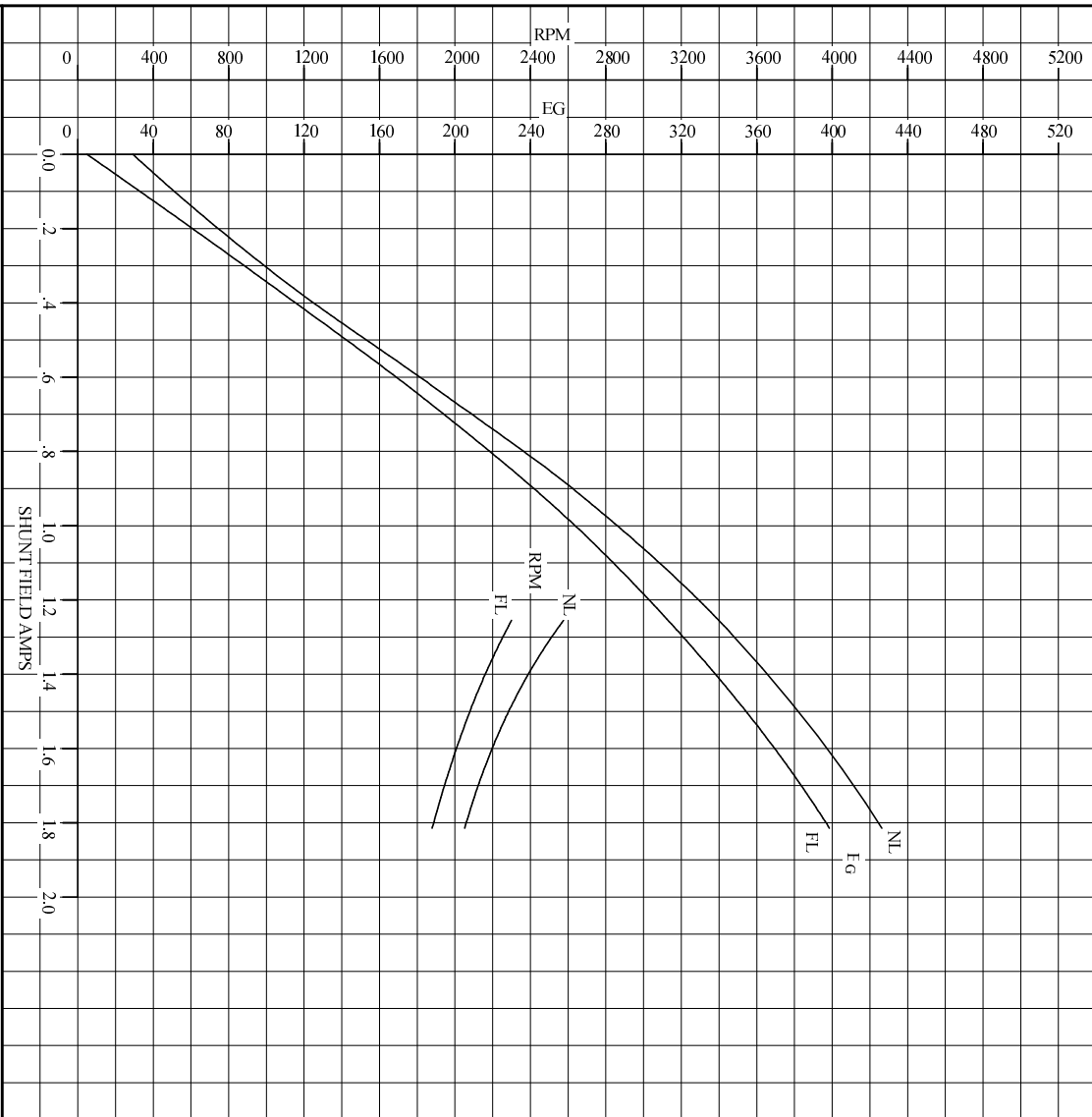

REMARKS: TYPICAL DATA
CURVES VALID FOR NAMEPLATE SPEED RANGE ONLY

RELIANCE ELECTRIC

DR. BY B. D. GRANT
CR. BY B. D. GRANT
APP. BY T. S. EVON
DATE 06/10/85

D-C APPLICATION DATA
SC6061B
ISSUE DATE 06/06/85

