

# **BALDOR® • RELIANCE**

## **Product Information Packet**

### **D5040RS-BV**

**40HP, 1750RPM, DC, 2512ATZ, DPG-FV,**

Copyright © All product information within this document is subject to Baldor Electric Company copyright © protection, unless otherwise noted.

Part Detail			
Type:	DC	Prod. Type:	TR
Power Code:	C	Weight:	570
Frame Group:	MC 2512ATZ	Mounting Pos.:	F2
HP:	40	Enclosure:	DPFV
RPM:	1750/2300	Wound:	STAB SHUNT
Service Factor:	1.0	Arm V:	500
Arm A:	68.50	Field V:	300
Field A:	2.88	Field A Hot:	2.08/1.31
Insulation Class:	F	Ambient:	40
Duty:	CONT	DE Bearing:	60BC03J30X
ODE Bearing:	50BC02J30X	Brushes:	419904-51AC
Brush Qty.:			

609952-096

**INDUSTRIAL DIRECT CURRENT MOTORS AND GENERATORS - RPM III**

ENCLOSURE: DRIP-PROOF FULLY-GUARDED, SPLASHPROOF  
 COOLING: FORCE VENTILATED WITH INTEGRAL BLOWER AND MOTOR AIR FILTERED-SPECIAL Baffle  
 MOUNTING: FOOT  
 METHOD OF DRIVE: COUPLED OR BELTED  
 FRAMES SC2113ATZ THRU C2813ATZ  
 ACCESSORIES: PROVISION FOR TACHOMETER MOUNTING ONLY WHEN SPECIFIED

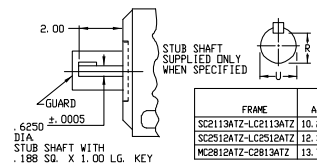
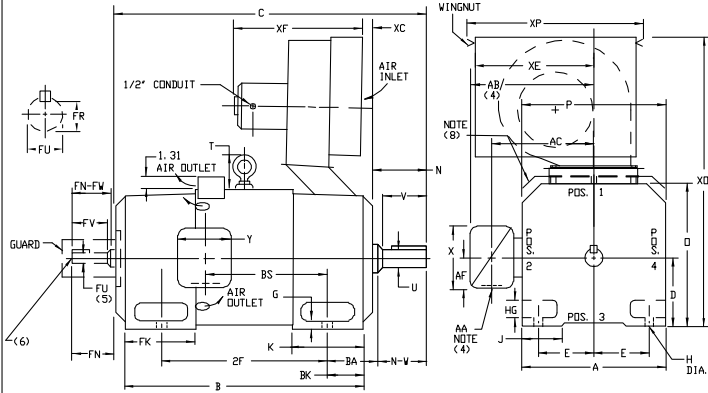

DIMENSIONS ARE IN INCHES

FRAME	XC	XE	XF	XD	XP
SC2113ATZ-LC2113ATZ	1.00	10.00	17.25	28.00	14.50
SC2512ATZ-LC2512ATZ	2.50	10.00	17.25	30.31	14.50
MC2812ATZ-C2813ATZ	1.75	10.00	18.50	30.62	14.50

FRAME	A	B	BS	2F	N	N-V	Y	RC3	SD	LGTL	FN	FN-FW	FK2D	FV	FR2D	SB	LGTL	WT	
SC2113ATZ	28.38	22.50	11.38	18.00	4.00	3.75	1.875	3.50	1.591	500	2.50	3.50	3.25	1.625	3.00	1.416	375	2.25	345
MC2113ATZ	29.62	23.75	12.62	18.00	4.00	3.75	1.875	3.50	1.591	500	2.50	3.50	3.25	1.625	3.00	1.416	375	2.25	370
LC2113ATZ	31.25	25.38	14.25	18.00	4.00	3.75	1.875	3.50	1.591	500	2.50	3.50	3.25	1.625	3.00	1.416	375	2.25	400
SC2512ATZ	31.69	25.06	12.06	20.00	4.50	4.25	2.125	4.00	1.845	500	3.00	4.00	3.75	1.875	3.50	1.591	500	2.50	535
MC2512ATZ	33.19	26.56	13.56	20.00	4.50	4.25	2.125	4.00	1.845	500	3.00	4.00	3.75	1.875	3.50	1.591	500	2.50	570
LC2512ATZ	34.69	28.06	15.06	20.00	4.50	4.25	2.125	4.00	1.845	500	3.00	4.00	3.75	1.875	3.50	1.591	500	2.50	610
MC2812ATZ	37.38	29.94	14.25	22.00	5.00	4.75	2.375	4.50	2.021	625	3.50	4.50	4.25	2.125	4.00	1.845	500	3.00	810
LC2812ATZ	39.62	32.19	16.50	22.00	5.00	4.75	2.375	4.50	2.021	625	3.50	4.50	4.25	2.125	4.00	1.845	500	3.00	885
LC2813ATZ	41.25	33.81	18.12	25.00	5.00	4.75	2.375	4.50	2.021	625	3.50	4.50	4.25	2.125	4.00	1.845	500	3.00	940

FRAME	C	B	BS	2F	N	N-V	Y	RC3	SD	LGTL	FN	FN-FW	FK2D	FV	FR2D	SB	LGTL	WT	
SC2113ATZ	28.38	22.50	11.38	18.00	4.00	3.75	1.875	3.50	1.591	500	2.50	3.50	3.25	1.625	3.00	1.416	375	2.25	345
MC2113ATZ	29.62	23.75	12.62	18.00	4.00	3.75	1.875	3.50	1.591	500	2.50	3.50	3.25	1.625	3.00	1.416	375	2.25	370
LC2113ATZ	31.25	25.38	14.25	18.00	4.00	3.75	1.875	3.50	1.591	500	2.50	3.50	3.25	1.625	3.00	1.416	375	2.25	400
SC2512ATZ	31.69	25.06	12.06	20.00	4.50	4.25	2.125	4.00	1.845	500	3.00	4.00	3.75	1.875	3.50	1.591	500	2.50	535
MC2512ATZ	33.19	26.56	13.56	20.00	4.50	4.25	2.125	4.00	1.845	500	3.00	4.00	3.75	1.875	3.50	1.591	500	2.50	570
LC2512ATZ	34.69	28.06	15.06	20.00	4.50	4.25	2.125	4.00	1.845	500	3.00	4.00	3.75	1.875	3.50	1.591	500	2.50	610
MC2812ATZ	37.38	29.94	14.25	22.00	5.00	4.75	2.375	4.50	2.021	625	3.50	4.50	4.25	2.125	4.00	1.845	500	3.00	810
LC2812ATZ	39.62	32.19	16.50	22.00	5.00	4.75	2.375	4.50	2.021	625	3.50	4.50	4.25	2.125	4.00	1.845	500	3.00	885
LC2813ATZ	41.25	33.81	18.12	25.00	5.00	4.75	2.375	4.50	2.021	625	3.50	4.50	4.25	2.125	4.00	1.845	500	3.00	940

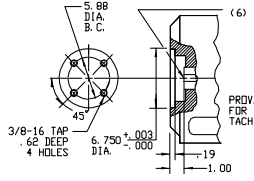

- (1) "P" DIMENSION WILL NOT BE EXCEEDED. SHIMS UP TO .03 INCHES IN THICKNESS ARE USUALLY REQUIRED FOR COUPLED OR GEARED MACHINES.
  - (2) "F" AND "FV" VARY .000 - .001.
  - (3) "R" AND "RV" VARY .000 - .015.
  - (4) TERMINAL BOX VARIES WITH H.P. FOR DIMENSIONS "AA", "AB", "AC", "AF", "AY" AND "AY". REFER TO BOX D/S (STD 609959-1, "X"PP 609959-2, WILL 609959-3).
  - (5) OPPOSITE DRIVE END SHAFT SUPPLIED ONLY WHEN SPECIFIED.
  - (6) MOTOR SHAFT TAPPED FOR SCREW-IN STUB SHAFT.
  - (7) WHEN THE MOTOR APPLICATION DOES NOT REQUIRE THE USE OF DPP DRIVE END, ADD .25 TO "C" DIM FOR BRACKET COVER.
  - (8) FOR HORIZONTAL APPLICATIONS ONLY.
- TERMINAL BOX CAN BE ROTATED FOR LEAD OUTLET AT TOP, SIDES OR BOTTOM. TERMINAL BOX LOCATED ON OPPOSITE SIDE WHEN F=2, V=1, W=4, W=5, W=7, OR C=1 MOUNTING IS SPECIFIED. BOX LOCATED ON TOP WHEN SPECIFIED. BLOWER ASSEMBLY CAN BE LOCATED AT POSITIONS 1, 2, OR 4. MOTOR WEIGHT MAY VARY 15% FOR NON-STANDARD RATINGS AND/OR ACCESSORIES. IF MOUNTING CLEARANCE DETAILS ARE REQUIRED, CONSULT FACTORY.

CUSTOMER IS RESPONSIBLE FOR DETERMINING THAT BALDOR'S PRODUCT WILL PERFORM SUITABLY IN THE INTENDED APPLICATION.

REV. DESC: LOADED TO BUS	VERSION: 00	TDR: 000000577407
REV. LTR: -	REVISED: 11:42:37 01/26/2011	BY: CONNAS
FILE: \RGG\00015\585		
MTL: -		

**BALDOR**

DIMENSION DRAWING, SC2113ATZ - C2813ATZ, DPP, FOOT MTG.  
 SH 1 of 1

609952-096

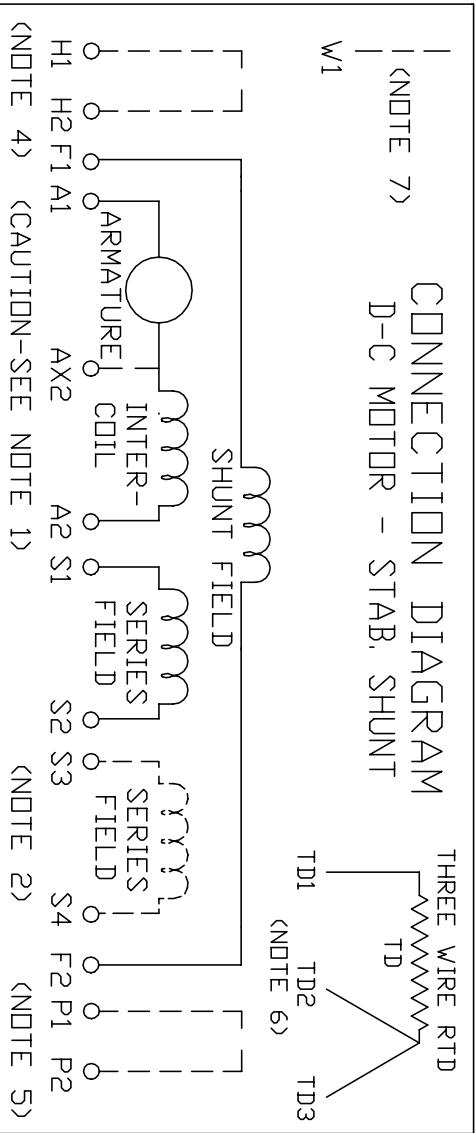

ARMATURE AND FIELD EXTERNAL CONNECTIONS  
WARNING- SEE NOTE 8 FOR GROUNDING INSTRUCTIONS



ROTATION FACING COMMUTATOR END

1. **CAUTION** — ARMATURE AND SERIES FIELD MAY HAVE MULTIPLE LEADS. CONNECT ALL LUGS WITH THE SAME MARKING TOGETHER.
2. OPTIONAL SERIES FIELD IS MARKED S3 AND S4. FOR CUMULATIVE SERIES FIELD, CONNECT S3 TO S2 AND CONNECT S4 TO NEGATIVE. FOR DIFFERENTIAL SERIES FIELD CONNECT S4 TO S2 AND S3 TO NEGATIVE.
3. OPTIONAL CONTROL SIGNAL LEAD IS MARKED AX2. ALWAYS TAKE INTERPOLE DROP BETWEEN A2 AND AX2. NOTE: NEMA DESIGNATION FOR AX2 IS LETTER C.
4. SPACE HEATERS, WHEN PROVIDED, WILL HAVE LEADS MARKED H1 AND H2, H3, H4, ETC.
5. THERMAL PROTECTOR, WHEN PROVIDED, WILL HAVE LEADS MARKED P1 AND P2, P3, P4, ETC.
6. WINDING RTDS, WHEN PROVIDED, WILL HAVE LEADS MARKED TD1, TD2, & TD3
7. BRUSH WEAR SENSOR, WHEN PROVIDED, WILL HAVE LEAD MARKED W1.
8. **WARNING** — MOTOR MUST BE GROUNDED TO PREVENT SERIOUS INJURIES TO PERSONNEL. GROUND THE MOTOR PER IEC, NATIONAL ELECTRICAL CODE AND ANY APPLICABLE LOCAL ELECTRICAL CODES. A TAPPED HOLE IS PROVIDED IN THE CONDUIT BOX, ON THE FOOT. FRAME BRACE OR OPPOSITE OPPOSITE DRIVE END BRACKET, ADJACENT TO THE TERMINAL BOX FOR FOR MOTOR GROUNDING. GROUND LEAD, WHEN PROVIDED, WILL BE GREEN.

CUSTOMER \_\_\_\_\_ RELIANCE  
ORDER NO. \_\_\_\_\_ S.D. NO. \_\_\_\_\_

<p style="text-align: center;"><b>RELIANCE ELECTRIC</b></p> <p style="text-align: center;">CLEVELAND, OHIO 44117 U.S.A.</p>	<p style="text-align: center;">Rev. by <u>N.L. EVANS</u> Ck. by <u>N. JESCHKE</u> App. by <u>E. L. HINER</u> DATE <u>5-5-69</u></p>
<p style="text-align: center;"><b>CONNECTION DIAGRAM</b></p> <p style="text-align: center; font-size: 24pt;"><b>406770-1</b></p> <p style="text-align: center;">ORIGINAL AT RCC</p>	

C/R 290048, 354478, 354480



REL S.O.	FRAME	RATING	RPM	ARM. VOLTS	ARM. AMPS
	MC2512ATZ	40.0HP	1750	500	68.5
WINDING TYPE		S.F.	ENCL.	AMB °C/INSUL	DUTY
STAB. SHUNT		1.0	DPFV	40/F	CONT
					300
POWER CODE		TYPE	WK 2 (LB-FT 2)	HOT ARM. CIR. RES.	FLD. AMPS@25 °C
6/6 460-50-0		TR	5.505	.601	2.88
					144
HOT FIELD RES					

ARM. CIR. IND. (mh)	FIELD IND. (H)	COOLING AIR (CFM/IN H 20)	TURNS PER COIL SHUNT/SERIES	TEST DATE
10.0	22.7	425/2.00	990/4	-

LOAD PERFORMANCE					
LOAD	AMPERES	TORQUE IN LB.-FT.	OUTPUT IN HP	RPM	% EFFICIENCY
NO LOAD	1.4	0	0	1910	0
1/4	17	29.0	10.3	1858	82.5
2/4	34	60.4	20.9	1819	87.5
3/4	51	91.0	31.1	1794	87.8
4/4	69	120	40.7	1778	86.8
O.L.	103	174	58.2	1761	83.4

RPM VS. FIELD AMPS			Eg VS. FIELD AMPS	
FIELD AMPS	RPM N.L.L.	RPM F.L.L.	Eg N.L.L. @ BASE SPEED	Eg F.L.L. @ BASE SPEED
2.08	1909	1777	455	416
1.84	2057	1893	425	385
1.61	2251	2040	388	350
1.38	2532	2234	345	311
1.14	2956	2500	295	268

REMARKS: TYPICAL DATA

MAXIMUM SAFE SPEED = 4500 RPM

	DR. BY R. BRILACHER	<b>D-C MOTOR PERFORMANCE DATA</b> DG6366D ISSUE DATE 09-26-2006
	CK. BY R. BRILACHER APP. BY E.H.GILLOT DATE 07-12-91	

C/R -

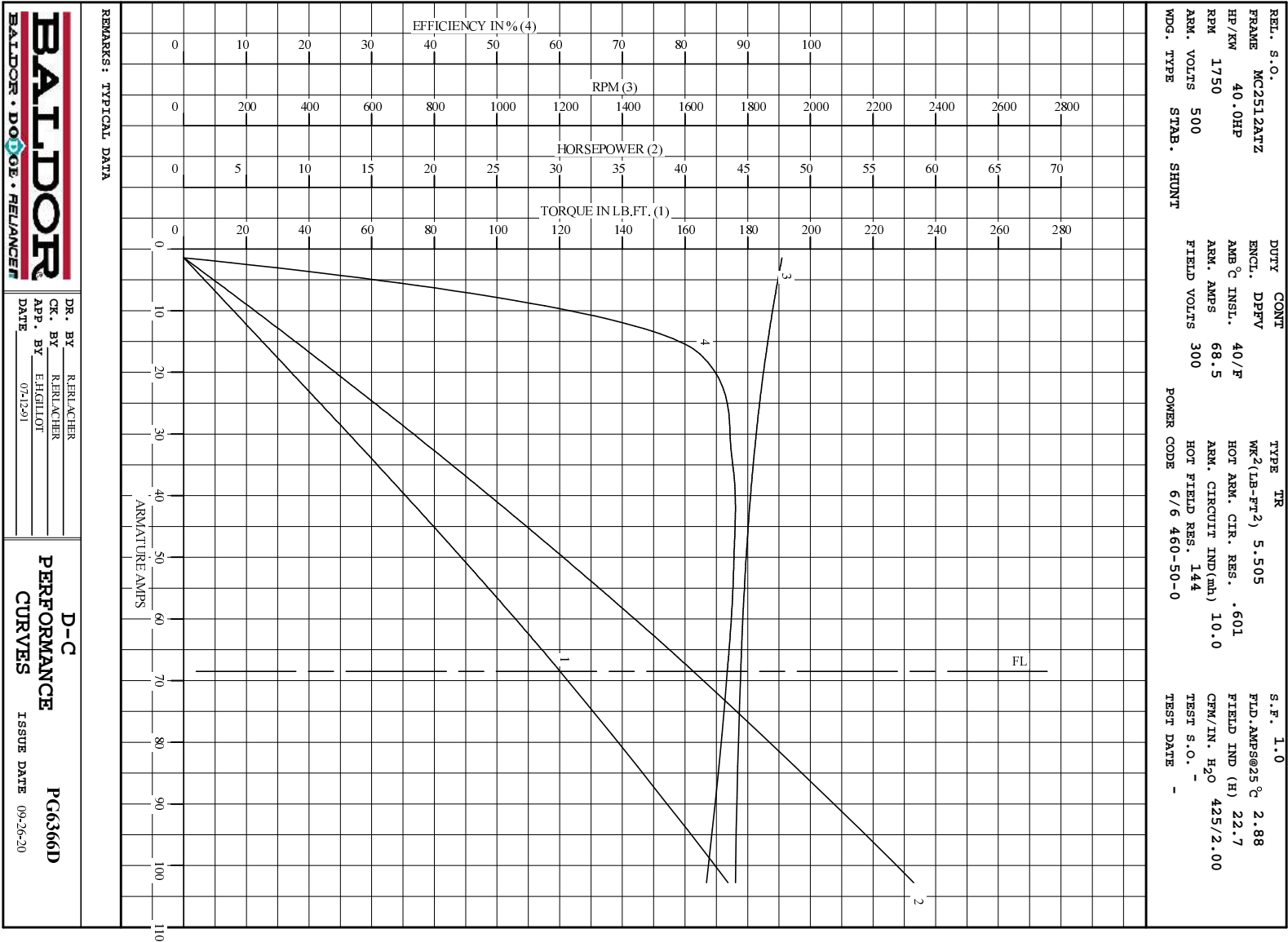

C/R