

BALDOR® • *RELIANCE*

Product Information Packet

ECP3587T-5

2HP,1755RPM,3PH,60HZ,145T,0535M,TEFC,F1

Copyright © All product information within this document is subject to Baldor Electric Company copyright © protection, unless otherwise noted.

Part Detail									
Revision:	C	Status:	PRD/A	Change #:		Proprietary:	No		
Type:	AC	Prod. Type:	0535M	Elec. Spec:	05WGX086	CD Diagram:			
Enclosure:	TEFC	Mfg Plant:		Mech. Spec:	05F008	Layout:			
Frame:	145T	Mounting:	F1	Poles:	04	Created Date:	11-23-2010		
Base:	RG	Rotation:	R	Insulation:	F	Eff. Date:	06-20-2012		
Leads:	3#18	Literature:		Elec. Diagram:		Replaced By:			
Nameplate NP2069E									
CAT.NO.	ECP3587T-5								
SPEC.	05F008X086G1								
HP	2								
VOLTS	575								
AMP	2.3								
RPM	1755								
FRAME	145T	HZ	60			PH	3		
SER.F.	1.15	CODE	L	DES	B	CL	F		
NEMA-NOM-EFF	88.5	PF	75						
RATING	40C AMB-CONT								
CC	010A	USABLE AT 208V							
DE	6205	ODE	6205						
ENCL	TEFC	SN							

Parts List		
Part Number	Description	Quantity
SA216901	SA 05F008X086G1	1.000 EA
RA204081	RA 05F008X086G1	1.000 EA
34FN3002B01	EXTERNAL FAN, PLASTIC, .637/.639 HUB W/	1.000 EA
S/P107-000-001	SUPER E PROC'S-FS & WS PLTS-POLYREX EM G	1.000 EA
HW3201A05	3/8-16 EYEBOLT	1.000 EA
06CB1000A02G	CONDUIT BOX, MACH GRAY	1.000 EA
RM1016	LEAD SEPARATOR GASKET - 305/306 C.P.MOTO	1.000 EA
51XW2520A12	.25-20 X .75, TAPTITE II, HEX WSHR SLTD	2.000 EA
11XW1032G06	10-32 X .38, TAPTITE II, HEX WSHR SLTD U	1.000 EA
HW3001B01	003SS CUP WASHER, FOR #8 SCREW	1.000 EA
10XN2520S06	1/4 20X3/8 HX HD CAP S.S.	2.000 EA
WD1000B16	KPA-4C BURNDY TERMINAL	2.000 EA
35EP1102B03G	FREP TEFC 205 BRG,GRSR,RLF,.125 NPT DRAI	1.000 EA
HW4500A01	1641B(ALEMITE)400 UNIV, GREASE FITT	1.000 EA
HA4051A00	PLASTIC CAP FOR GREASE FITTING	1.000 EA
HW4500A17	317400 ALEMITE GREASE RELIEF	1.000 EA
HA4001A01SP	DRAIN PLUG, PLASTIC (MICRO PLAS)	1.000 EA
HW5100A05	WVY WSHR F/205 & 304 BRGS	1.000 EA
35EP1102A67G	PUEP ENCL 205 BRG W/GRSR,REL F&.125 NPT D	1.000 EA
HW4500A01	1641B(ALEMITE)400 UNIV, GREASE FITT	1.000 EA
HA4051A00	PLASTIC CAP FOR GREASE FITTING	1.000 EA
HW4500A17	317400 ALEMITE GREASE RELIEF	1.000 EA
HA4001A01SP	DRAIN PLUG, PLASTIC (MICRO PLAS)	1.000 EA
HA3100A37	THRUBOLT 10-32 X 8.500	4.000 EA

Parts List (continued)		
Part Number	Description	Quantity
XY1032A02	10-32 HEX NUT DIRECTIONAL SERRATION	4.000 EA
51XB1214A16	12-14X1.00 HXWSSLD SERTYB	1.000 EA
35FH1000A01G	35FH1000A01 W/GRAY FLUIDIZ	1.000 EA
WD4100A03	DE-750 HEYCO PLUG 62MP0750 MICRO PLASTIC	1.000 EA
10XN2520A16	1/4-20 X 1 HEX HEAD CAP SCR, ZINC PLATED	3.000 EA
HW1001A25	LOCKWASHER 1/4, ZINC PLT .493 OD, .255 I	3.000 EA
06CB1502A01G	LIPPED CONDUIT BOX LID, MACH GRAY EPOXY	1.000 EA
06GS1003	GASKET, KOBX LID, 1/8" THICK BLACK NEOPR	1.000 EA
10XN2520A12	O1/4-20X 3/4 HEX HEAD CAP	2.000 EA
HW1001A25	LOCKWASHER 1/4, ZINC PLT .493 OD, .255 I	2.000 EA
HW4600B32SP	V-RING SLINGER 1.000 X 1.540 X 0.240	1.000 EA
HA1005A03SP	SLINGER, OD 1.750, ID .938, 205 BRG	1.000 EA
HW2501D13SP	KEY, 3/16 SQ X 1.375	1.000 EA
HA7000A01	KEY RETAINER 7/8" DIA SHAFT	1.000 EA
MJ5001A01	46-665 RED SEALER	0.001 QT
85XU0407S04	4X1/4 U DRIVE PIN STAINLESS	2.000 EA
LB1002	LABEL,MARINE DUTY (ON ROLLS)	1.000 EA
LB1115	LABEL,LIFTING DEVICE	1.000 EA
MJ1000A75	GREASE, POLYREX EM EXXON	0.050 LB
MG1025N19	PAINT, 778.50 WILKO, RELIANCE ELEC GREEN	0.022 GA
LB1119	WARNING LABEL	1.000 EA
LB1125C02	SUPER-E (STOCK CTN LABEL SUPER-E WITH FL	1.000 EA
LB1357	ENERGY GUIDE LABEL (BOX LABEL)	1.000 SH
LC0006	CONNECTION LABEL	1.000 EA

Parts List (continued)		
Part Number	Description	Quantity
NP2069E	SS CP SUPER-E UL CSA-EEV CC REV MTG	1.000 EA
36PA1001	PACKAGING GROUP	1.000 EA

Accessories		
Part Number	Description	Multiplier
35-1300	C FACE KIT	A8

Performance Data at 575V, 60Hz, 2.0HP (Typical performance - Not guaranteed values)

General Characteristics							
Full Load Torque:	6.02 LB-FT			Start Configuration:	DOL		
No-Load Current:	1.28 Amps			Break-Down Torque:	26.1 LB-FT		
Line-line Res. @ 25°C.:	10.5 Ohms A Ph / 0.0 Ohms B Ph			Pull-Up Torque:	20.1 LB-FT		
Temp. Rise @ Rated Load:	38 C			Locked-Rotor Torque:	21.2 LB-FT		
Temp. Rise @ S.F. Load:	45 C			Starting Current:	19.6 Amps		
Load Characteristics							
% of Rated Load	25	50	75	100	125	150	S.F.
Power Factor:	34.0	55.0	67.0	76.0	81.0	83.0	79.0
Efficiency:	79.7	86.8	88.1	88.5	87.8	86.7	88.1
Speed:	1790.0	1779.0	1768.0	1755.0	1742.0	1728.0	1747.0
Line Amperes:	1.36	1.58	1.89	2.25	2.66	3.1	2.5

Performance Graph at 575V, 60Hz, 2.0HP Typical performance - Not guaranteed values

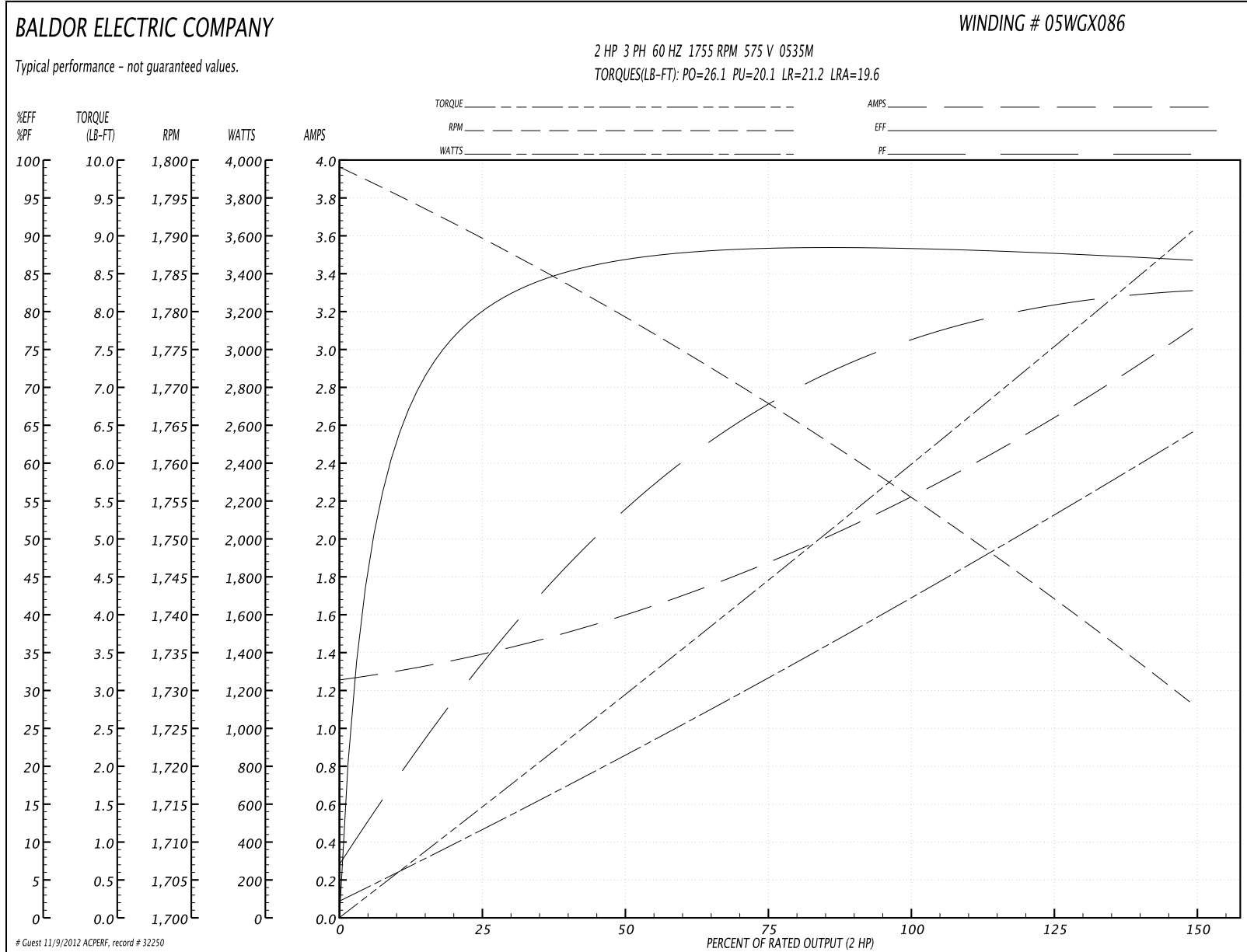

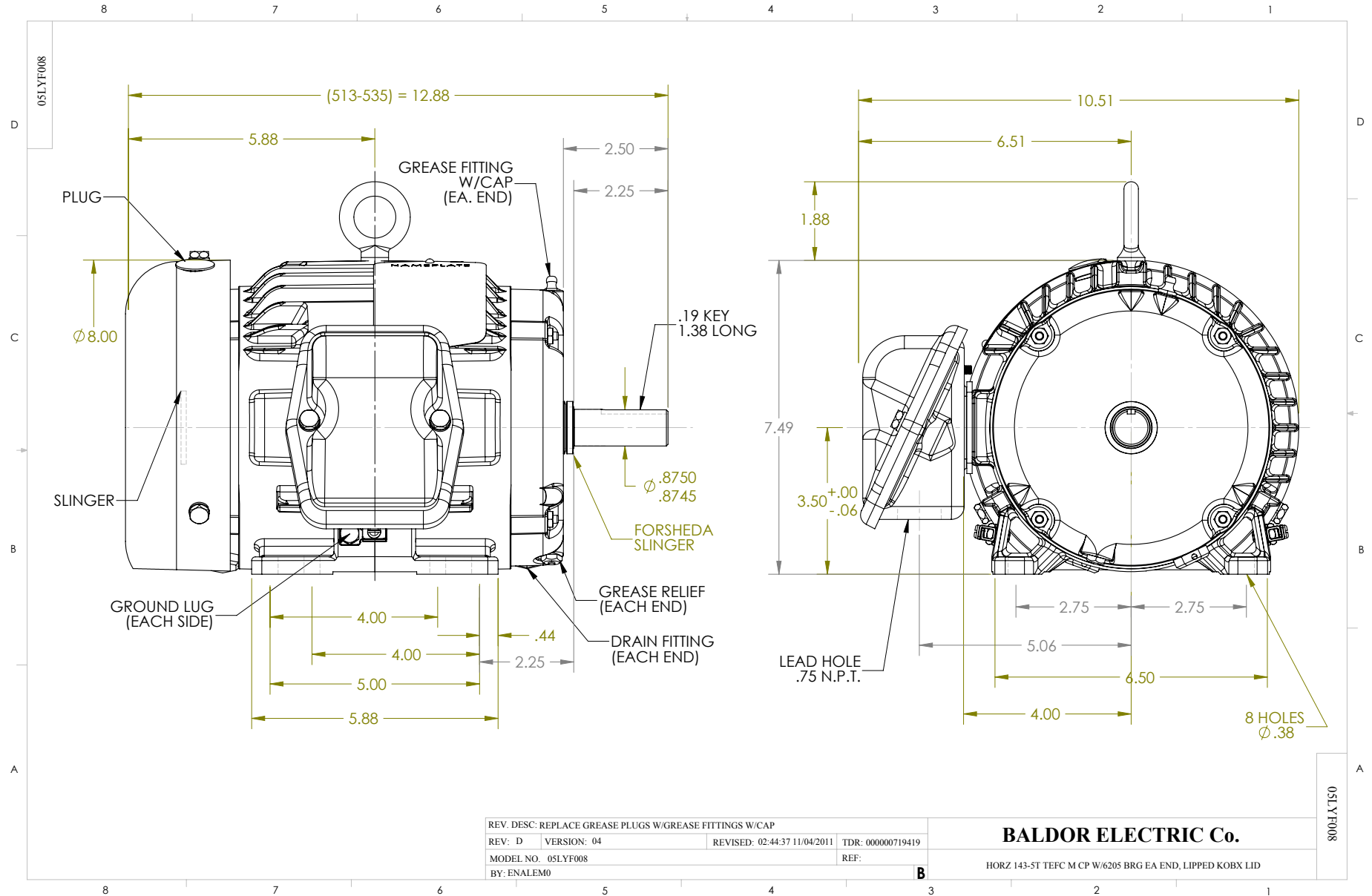

CD0006



NOTES:

1. THREE LEAD MOTOR MAY BE EITHER WYE CONNECTED OR DELTA CONNECTED.
2. INTERCHANGE ANY TWO LINE LEADS TO REVERSE ROTATION.
3. OPTIONAL THERMOSTATS ARE PROVIDED WHEN SPECIFIED.
4. ACTUAL NUMBER OF INTERNAL PARALLEL CIRCUITS MAY VARY.
5. LEAD COLORS ARE OPTIONAL. LEADS MUST BE NUMBERED AS SHOWN.

REV. DESC: REVISE TO SHOW OPTIONAL COLORS			
REV. LTR: D	BY: JLP	REVISED: 01/21/99 4:02	TDR: 0171435
9000D		FILE: AAA00005141	MDL: -
		MTL: -	

BALDOR ELECTRIC Co.

3PH, SV, 3 LEADS, WYE OR DELTA CONNECTED

CD0006