

BALDOR® • *RELIANCE*

Product Information Packet

ECP3661T-5

3HP,1760RPM,3PH,60HZ,182T,0635M,TEFC,F1

Copyright © All product information within this document is subject to Baldor Electric Company copyright © protection, unless otherwise noted.

Part Detail							
Revision:	E	Status:	PRD/A	Change #:		Proprietary:	No
Type:	AC	Prod. Type:	0635M	Elec. Spec:	06WGX294	CD Diagram:	
Enclosure:	TEFC	Mfg Plant:		Mech. Spec:	06H483	Layout:	
Frame:	182T	Mounting:	F1	Poles:	04	Created Date:	06-29-2011
Base:	RG	Rotation:	R	Insulation:	F	Eff. Date:	04-23-2012
Leads:	3#16	Literature:		Elec. Diagram:		Replaced By:	

Nameplate NP1260E									
CAT.NO.	ECP3661T-5								
SPEC.	06H483X294G1								
HP	3								
VOLTS	575								
AMP	3.4								
RPM	1760								
FRAME	182T	HZ			60	PH	3		
SER.F.	1.15	CODE			K	DES	B	CL	F
NEMA-NOM-EFF	90.2	PF			74				
RATING	40C AMB-CONT								
CC	010A	USABLE AT 208V							
DE	6206	ODE			6206				
ENCL	TEFC	SN							

Parts List		
Part Number	Description	Quantity
SA226295	SA 06H483X294G1	1.000 EA
RA213393	RA 06H483X294G1	1.000 EA
36FN3000C01SP	EXFN, PLASTIC, 5.25 OD, .912 ID	1.000 EA
S/P107-000-001	SUPER E PROC'S-FS & WS PLTS-POLYREX EM G	1.000 EA
HW3201A05	3/8-16 EYEBOLT	1.000 EA
06CB1000A02G	CONDUIT BOX, MACH GRAY	1.000 EA
RM1016	LEAD SEPARATOR GASKET - 305/306 C.P.MOTO	1.000 EA
51XW2520A12	.25-20 X .75, TAPTITE II, HEX WSHR SLTD	2.000 EA
11XW1032G06	10-32 X .38, TAPTITE II, HEX WSHR SLTD U	1.000 EA
HW3001B01	003SS CUP WASHER, FOR #8 SCREW	1.000 EA
10XN2520S06	1/4 20X3/8 HX HD CAP S.S.	2.000 EA
WD1000B16	KPA-4C BURNDY TERMINAL	2.000 EA
36EP1100B72G	FREP 6206,GRSR,RLF, .25-20 FH HOLES,DRAIN	1.000 EA
HW4500A17	317400 ALEMITE GREASE RELIEF	1.000 EA
HW4500A01	1641B(ALEMITE)400 UNIV, GREASE FITT	1.000 EA
HA4051A00	PLASTIC CAP FOR GREASE FITTING	1.000 EA
HA4001A01SP	DRAIN PLUG, PLASTIC (MICRO PLAS)	1.000 EA
HW5100A06	W2420-025 WVY WSHR (WB)	1.000 EA
36EP1100A29G	PU ENDPLATE MACH, GRAY	1.000 EA
HW4500A01	1641B(ALEMITE)400 UNIV, GREASE FITT	1.000 EA
HA4051A00	PLASTIC CAP FOR GREASE FITTING	1.000 EA
HW4500A17	317400 ALEMITE GREASE RELIEF	1.000 EA
HA4001A01SP	DRAIN PLUG, PLASTIC (MICRO PLAS)	1.000 EA
HA3101A34	THRUBOLT- 1/4-20 X 10.375	4.000 EA

Parts List (continued)		
Part Number	Description	Quantity
XY2520A12	1/4-20 HEX NUT, DIRECTIONAL SERRATIONS	4.000 EA
06FH1004A01G	FAN HOUSING MACH, W/GRAY EPOXY	1.000 EA
WD4100A02	DP-1000 HEYCO PLUG OR 62MP1000 MICRO PL	1.000 EA
10XN2520A24	1/4-20X 1 1/2 HEX HD X	3.000 EA
06CB1502A01G	LIPPED CONDUIT BOX LID, MACH GRAY EPOXY	1.000 EA
06GS1003	GASKET, KOBX LID, 1/8" THICK BLACK NEOPR	1.000 EA
10XN2520A12	O1/4-20X 3/4 HEX HEAD CAP	2.000 EA
HW1001A25	LOCKWASHER 1/4, ZINC PLT .493 OD, .255 I	2.000 EA
HA1005A22	SLINGER, OD 2.00, ID 1.14, 206 BRG, GM	1.000 EA
HW4600B36SP	V-RING SLINGER 1.188 X 1.690 X 0.240	1.000 EA
HW2501E16	3KEY, 1/4 SQ X 1.750	1.000 EA
HA7000A02	KEY RETAINER RING, 1 1/8 DIA, 1 3/8 DIA	1.000 EA
MJ5001A01	46-665 RED SEALER	0.001 QT
85XU0407S04	4X1/4 U DRIVE PIN STAINLESS	2.000 EA
LB1115	LABEL,LIFTING DEVICE	1.000 EA
LB1002	LABEL,MARINE DUTY (ON ROLLS)	1.000 EA
MJ1000A75	GREASE, POLYREX EM EXXON	0.050 LB
MG1025N19	PAINT, 778.50 WILKO, RELIANCE ELEC GREEN	0.028 GA
LB1119	WARNING LABEL	1.000 EA
LB1125C02	SUPER-E (STOCK CTN LABEL SUPER-E WITH FL	1.000 EA
LC0006	CONNECTION LABEL	1.000 EA
LB1357	ENERGY GUIDE LABEL (BOX LABEL)	1.000 SH
NP1260E	SS CP SUPER-E UL CSA CC	1.000 EA
36PA1001	PACKAGING GROUP	1.000 EA

Accessories		
Part Number	Description	Multiplier
36-1749	C FACE KIT	A8

Performance Data at 575V, 60Hz, 3.0HP (Typical performance - Not guaranteed values)

General Characteristics							
Full Load Torque:	8.98 LB-FT			Start Configuration:	DOL		
No-Load Current:	1.94 Amps			Break-Down Torque:	37.8 LB-FT		
Line-line Res. @ 25°C.:	5.71 Ohms A Ph / 0.0 Ohms B Ph			Pull-Up Torque:	18.7 LB-FT		
Temp. Rise @ Rated Load:	32 C			Locked-Rotor Torque:	22.2 LB-FT		
Temp. Rise @ S.F. Load:	38 C			Starting Current:	27.0 Amps		
Load Characteristics							
% of Rated Load	25	50	75	100	125	150	S.F.
Power Factor:	34.0	54.0	66.0	73.0	79.0	82.0	77.0
Efficiency:	81.9	88.8	90.2	90.3	90.0	88.6	90.1
Speed:	1791.0	1783.0	1774.0	1764.0	1754.0	1741.0	1758.0
Line Amperes:	2.1	2.4	2.86	3.41	4.0	4.84	3.76

Performance Graph at 575V, 60Hz, 3.0HP Typical performance - Not guaranteed values

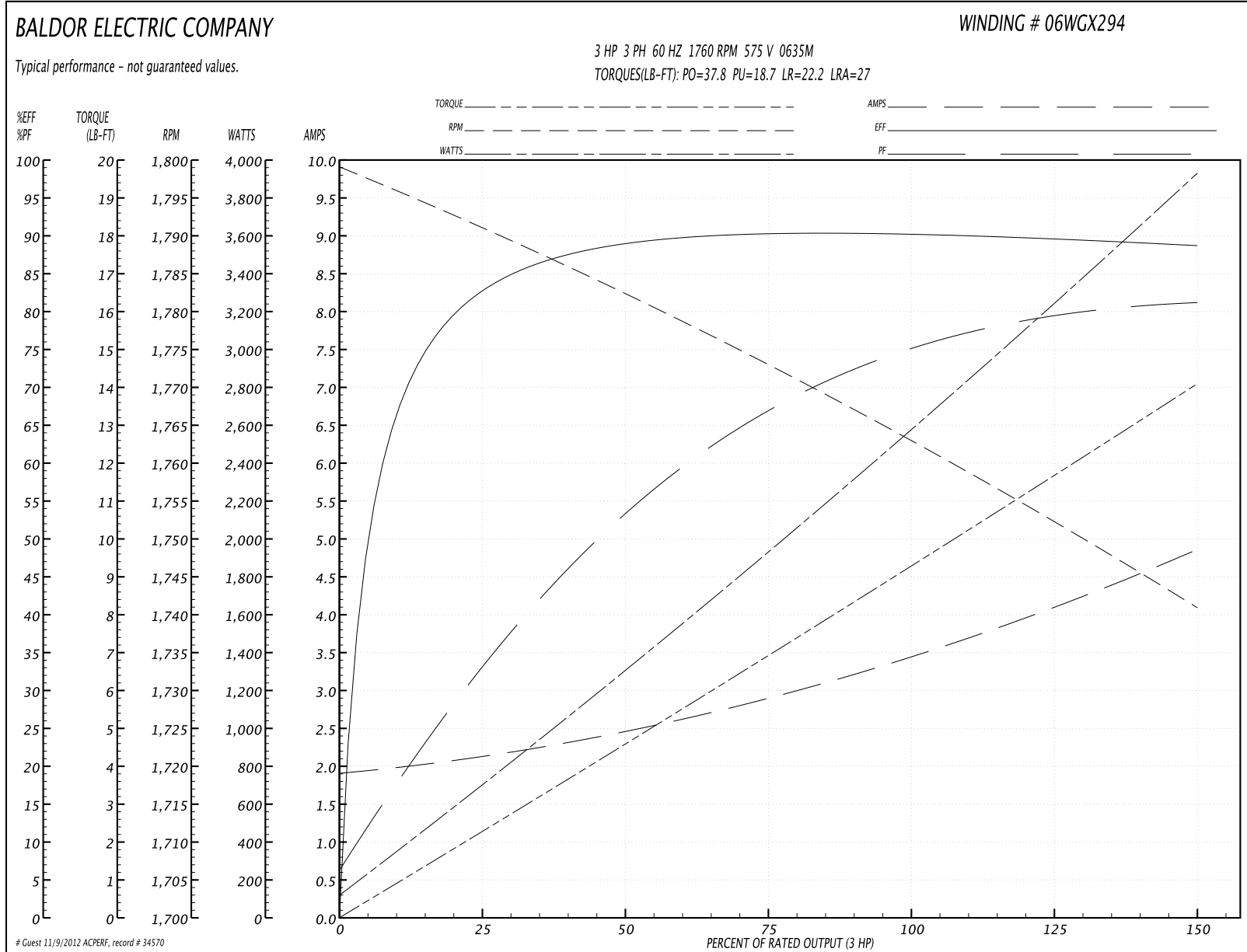

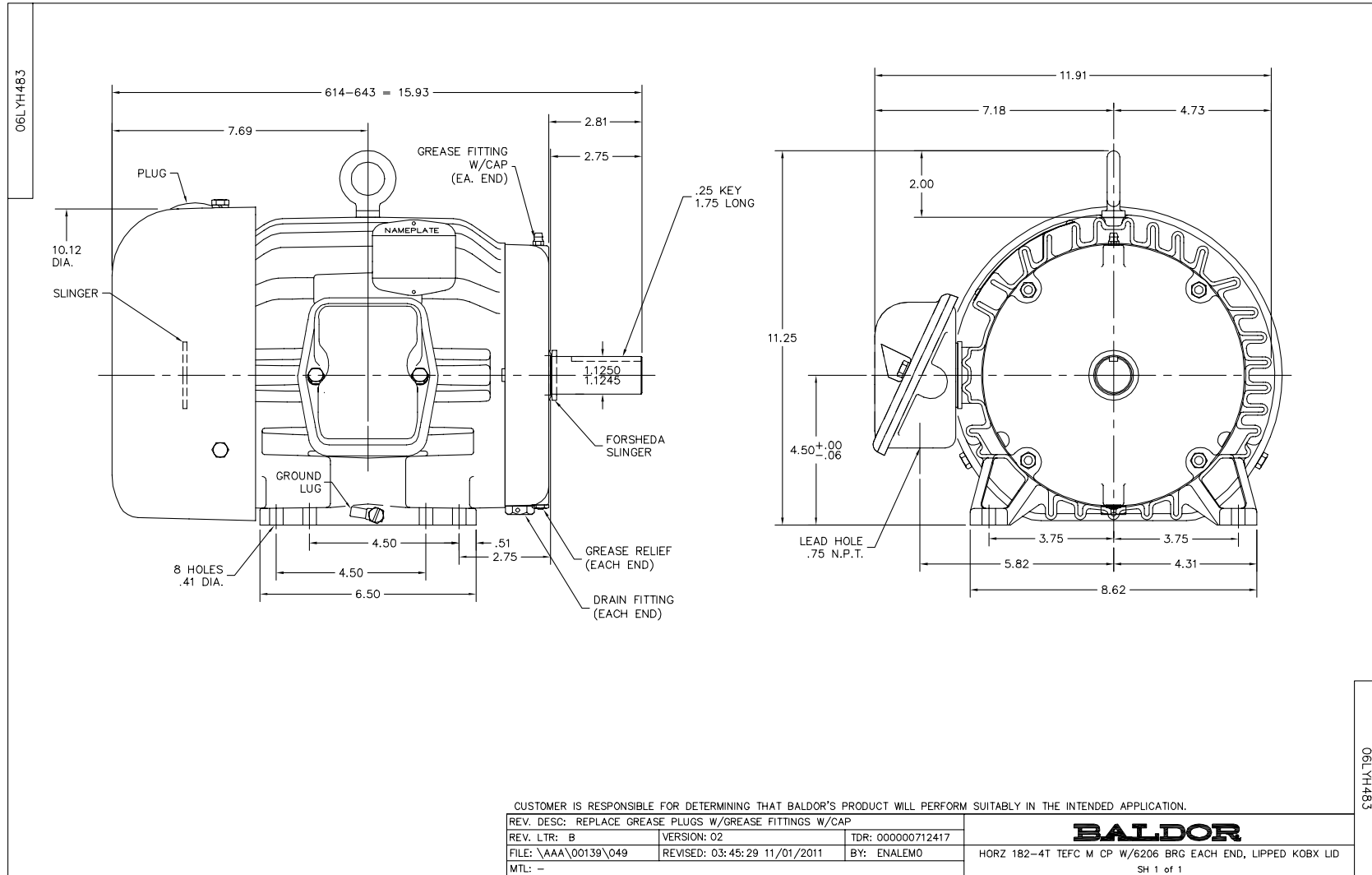

CD0006

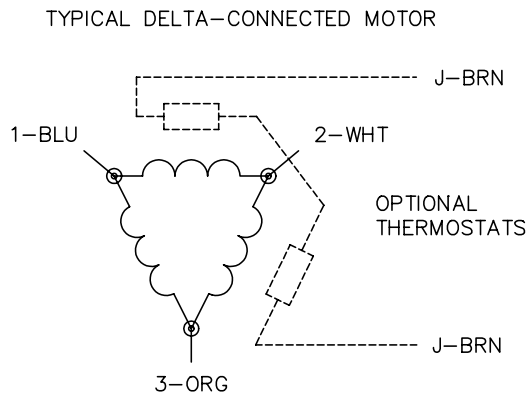
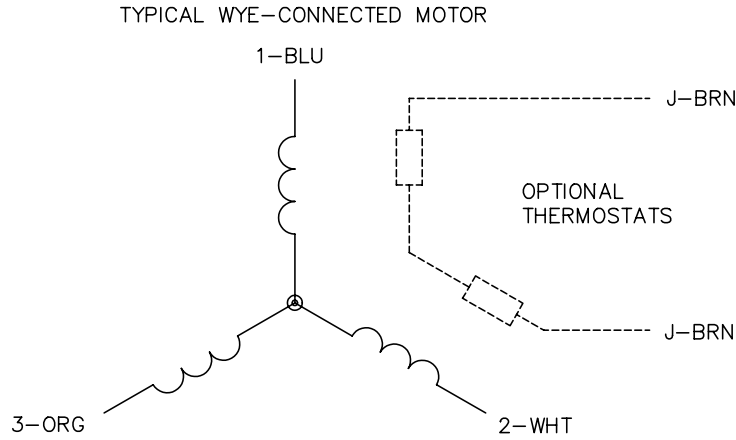

NOTES:

1. THREE LEAD MOTOR MAY BE EITHER WYE CONNECTED OR DELTA CONNECTED.
2. INTERCHANGE ANY TWO LINE LEADS TO REVERSE ROTATION.
3. OPTIONAL THERMOSTATS ARE PROVIDED WHEN SPECIFIED.
4. ACTUAL NUMBER OF INTERNAL PARALLEL CIRCUITS MAY VARY.
5. LEAD COLORS ARE OPTIONAL. LEADS MUST BE NUMBERED AS SHOWN.

REV. DESC: REVISE TO SHOW OPTIONAL COLORS			
REV. LTR: D	BY: JLP	REVISED: 01/21/99 4:02	TDR: 0171435
9000D		FILE: AAA00005141	MDL: -
		MTL: -	

BALDOR ELECTRIC Co.

3PH, SV, 3 LEADS, WYE OR DELTA CONNECTED

CD0006