

BALDOR® • RELIANCE

Product Information Packet

ECP4102T-4

20HP, 1180RPM, 3PH, 60HZ, 286T, 1062M, TEFC, F1

Copyright © All product information within this document is subject to Baldor Electric Company copyright © protection, unless otherwise noted.

| Part Detail | | | | | | | |
|-------------|------|-------------|-------|----------------|----------|---------------|------------|
| Revision: | A | Status: | PRD/A | Change #: | | Proprietary: | No |
| Type: | AC | Prod. Type: | 1062M | Elec. Spec: | 10WGY160 | CD Diagram: | |
| Enclosure: | TEFC | Mfg Plant: | | Mech. Spec: | 10G414 | Layout: | |
| Frame: | 286T | Mounting: | F1 | Poles: | 06 | Created Date: | 04-22-2010 |
| Base: | RG | Rotation: | R | Insulation: | F | Eff. Date: | 10-04-2011 |
| Leads: | 3#10 | Literature: | | Elec. Diagram: | | Replaced By: | |

Nameplate NP1260E

| | | | | | | | |
|--------------|--------------|----------------|------|-----|---|----|---|
| CAT.NO. | ECP4102T-4 | | | | | | |
| SPEC. | 10G414Y160G1 | | | | | | |
| HP | 20 | | | | | | |
| VOLTS | 460 | | | | | | |
| AMP | 26 | | | | | | |
| RPM | 1180 | | | | | | |
| FRAME | 286T | HZ | 60 | PH | 3 | | |
| SER.F. | 1.15 | CODE | H | DES | A | CL | F |
| NEMA-NOM-EFF | 93 | PF | 78 | | | | |
| RATING | 40C AMB-CONT | | | | | | |
| CC | 010A | USABLE AT 208V | | | | | |
| DE | 6311 | ODE | 6311 | | | | |
| ENCL | TEFC | SN | | | | | |
| | | | | | | | |

| Parts List | | |
|----------------|--|----------|
| Part Number | Description | Quantity |
| SA194779 | SA 10G414Y160G1 | 1.000 EA |
| RA182362 | RA 10G414Y160G1 | 1.000 EA |
| 09FN3001B02 | EXTERNAL FAN, PLASTIC | 1.000 EA |
| S/P107-000-004 | SUPER-E(284 FR. & UP)-CL PLANT,POLYREX E | 1.000 EA |
| 10CB1000A09P | CONDUIT BOX, MACH W/EPOXY PRIMER | 1.000 EA |
| 09GS1010 | GASKET, DWG, LEADWIRE SEPERATOR | 1.000 EA |
| 10XN3118K16 | 5/16-18 X 1" GRADE #5, STL, ZINC PLATE | 4.000 EA |
| HW1001A31 | LOCKWASHER 5/16, ZINC PLT.591 OD, .319 I | 4.000 EA |
| 10CB1503A01P | CONDUIT BOX LIPPED LID, MACH W/EPXY PRMR | 1.000 EA |
| 14GS1003 | GASKET CONDUIT BOX LID, NEOP | 1.000 EA |
| 10XN2520K16 | 1/4-20 X 1" HX HD SCRW GRADE 5, ZINC P | 4.000 EA |
| HW1001A25 | LOCKWASHER 1/4, ZINC PLT .493 OD, .255 I | 4.000 EA |
| HW2501H28 | KEY, 1/2 SQ X 3.250 | 1.000 EA |
| MJ5001A01 | 46-665 RED SEALER | 0.031 QT |
| MJ5001A14 | DYNAPRO SEAL, CP MOTORS VC#2508050 (603 | 0.026 EA |
| LB1115 | LABEL,LIFTING DEVICE | 1.000 EA |
| LB1002 | LABEL,MARINE DUTY (ON ROLLS) | 1.000 EA |
| LB5040 | INSTRUCTION TAG, AC & DC | 1.000 EA |
| 10EP1110A06GP6 | FREP, MACH W/PRIMER & GREEN PAINT | 1.000 EA |
| HA4051A00 | PLASTIC CAP FOR GREASE FITTING | 1.000 EA |
| HW4500A17 | 317400 ALEMITE GREASE RELIEF | 1.000 EA |
| HW4500A03 | GREASE FITTING, .125 NPT 1610(ALEMITE) 8 | 1.000 EA |
| HA4001A01SP | DRAIN PLUG, PLASTIC (MICRO PLAS) | 1.000 EA |
| HW2500A25 | WOODRUFF KEY USA #1008 #BLOW CARBON STEE | 1.000 EA |

| Parts List (continued) | | |
|------------------------|--|----------|
| Part Number | Description | Quantity |
| 51XB1214A20 | 12-14X1.25 HXWSSLD SERTYB | 1.000 EA |
| MG1025N19 | PAINT, 778.50 WILKO, RELIANCE ELEC GREEN | 0.070 GA |
| 85XU0407S04 | 4X1/4 U DRIVE PIN STAINLESS | 2.000 EA |
| LB1119 | WARNING LABEL | 1.000 EA |
| LB1125C02 | SUPER-E (STOCK CTN LABEL SUPER-E WITH FL | 4.000 EA |
| LB1357 | ENERGY GUIDE LABEL (BOX LABEL) | 1.000 SH |
| LC0006 | CONNECTION LABEL | 1.000 EA |
| NP1260E | SS CP SUPER-E UL CSA CC | 1.000 EA |
| 10PA1000 | PACKAGING GROUP COMBINED PRINT PK1023A06 | 1.000 EA |
| HW4500A21 | 1618BALEMITE FITTING 825 UNIVERSAL | 1.000 EA |
| HW4500A17 | 317400 ALEMITE GREASE RELIEF | 1.000 EA |
| HA4001A01SP | DRAIN PLUG, PLASTIC (MICRO PLAS) | 1.000 EA |
| MJ1000A75 | GREASE, POLYREX EM EXXON | 0.130 LB |
| HA4051A00 | PLASTIC CAP FOR GREASE FITTING | 1.000 EA |
| WD1000B16 | KPA-4C BURNDY TERMINAL | 1.000 EA |
| 10XN2520K06 | 1/4-20 X 3/8" HX HD SCREWGRADE 5, ZINC P | 1.000 EA |
| HW1001A25 | LOCKWASHER 1/4, ZINC PLT .493 OD, .255 I | 1.000 EA |
| 10XN3816K28 | 3/8-16 X 1.75 HEX HD CAP SCREW, GRADE 5 | 4.000 EA |
| HW1001A38 | LOCKWASHER 3/8, ZINC PLT .688 OD, .382 I | 4.000 EA |
| 10XN3118K40 | 5/16-18 X 2.50" HEX HD, GRADE 5 | 4.000 EA |
| HW4600B40 | V-RING SLINGER 2.000 X 2.680 X 0.280 | 1.000 EA |
| 10FH1007P | FAN COVER, CAST W/EPOXY PRIMER | 1.000 EA |
| 10XN3118K20 | 5/16-18 X 1 1/4 GRADE 5 STEEL ZC PLATED | 3.000 EA |
| HW1001A31 | LOCKWASHER 5/16, ZINC PLT.591 OD, .319 I | 3.000 EA |

| Parts List (continued) | | |
|------------------------|--|----------|
| Part Number | Description | Quantity |
| HA4017A11 | 1/8 X 2.75 GREASE EXT (F/S) | 1.000 EA |
| HA4017A03 | .125 X 1.75 GREASE EXT (F/S) | 1.000 EA |
| HA4024A02 | 1/8 DOUBLE FEMALE SS CPLG, MCM #4464K351 | 1.000 EA |
| HA1005A04SP | SLINGER, OD 3.620, ID 1.98, | 1.000 EA |
| HW5100A13 | W4627-047 WVY WSHER | 1.000 EA |
| 10XN3118K36 | 5/16-18 X 2.25" HEX HD, GRADE 5 | 4.000 EA |
| 10EP1105A01P | MACH'D EPOXY PRIMED EP | 1.000 EA |
| HW1001A38 | LOCKWASHER 3/8, ZINC PLT .688 OD, .382 I | 4.000 EA |
| 10XN3816K28 | 3/8-16 X 1.75 HEX HD CAP SCREW, GRADE 5 | 4.000 EA |

| Accessories | | |
|-------------|-------------|------------|
| Part Number | Description | Multiplier |
| 10-1305 | C FACE KIT | A8 |

Performance Data at 460V, 60Hz, 20.0HP (Typical performance - Not guaranteed values)

| General Characteristics | | | | | | | |
|--------------------------|---------------------------------|--------|--------|----------------------|-------------|--------|--------|
| Full Load Torque: | 89.0 LB-FT | | | Start Configuration: | DOL | | |
| No-Load Current: | 12.3 Amps | | | Break-Down Torque: | 286.9 LB-FT | | |
| Line-line Res. @ 25°C.: | 0.362 Ohms A Ph / 0.0 Ohms B Ph | | | Pull-Up Torque: | 113.0 LB-FT | | |
| Temp. Rise @ Rated Load: | 47 C | | | Locked-Rotor Torque: | 160.5 LB-FT | | |
| Temp. Rise @ S.F. Load: | 59 C | | | Starting Current: | 171.6 Amps | | |
| Load Characteristics | | | | | | | |
| % of Rated Load | 25 | 50 | 75 | 100 | 125 | 150 | S.F. |
| Power Factor: | 39.0 | 61.0 | 72.0 | 78.0 | 80.0 | 81.0 | 79.0 |
| Efficiency: | 88.5 | 92.5 | 93.3 | 93.2 | 92.6 | 91.7 | 92.8 |
| Speed: | 1195.0 | 1191.0 | 1187.0 | 1183.0 | 1178.0 | 1173.0 | 1180.0 |
| Line Amperes: | 13.6 | 16.9 | 21.0 | 25.9 | 31.4 | 37.7 | 29.2 |

Performance Graph at 460V, 60Hz, 20.0HP Typical performance - Not guaranteed values

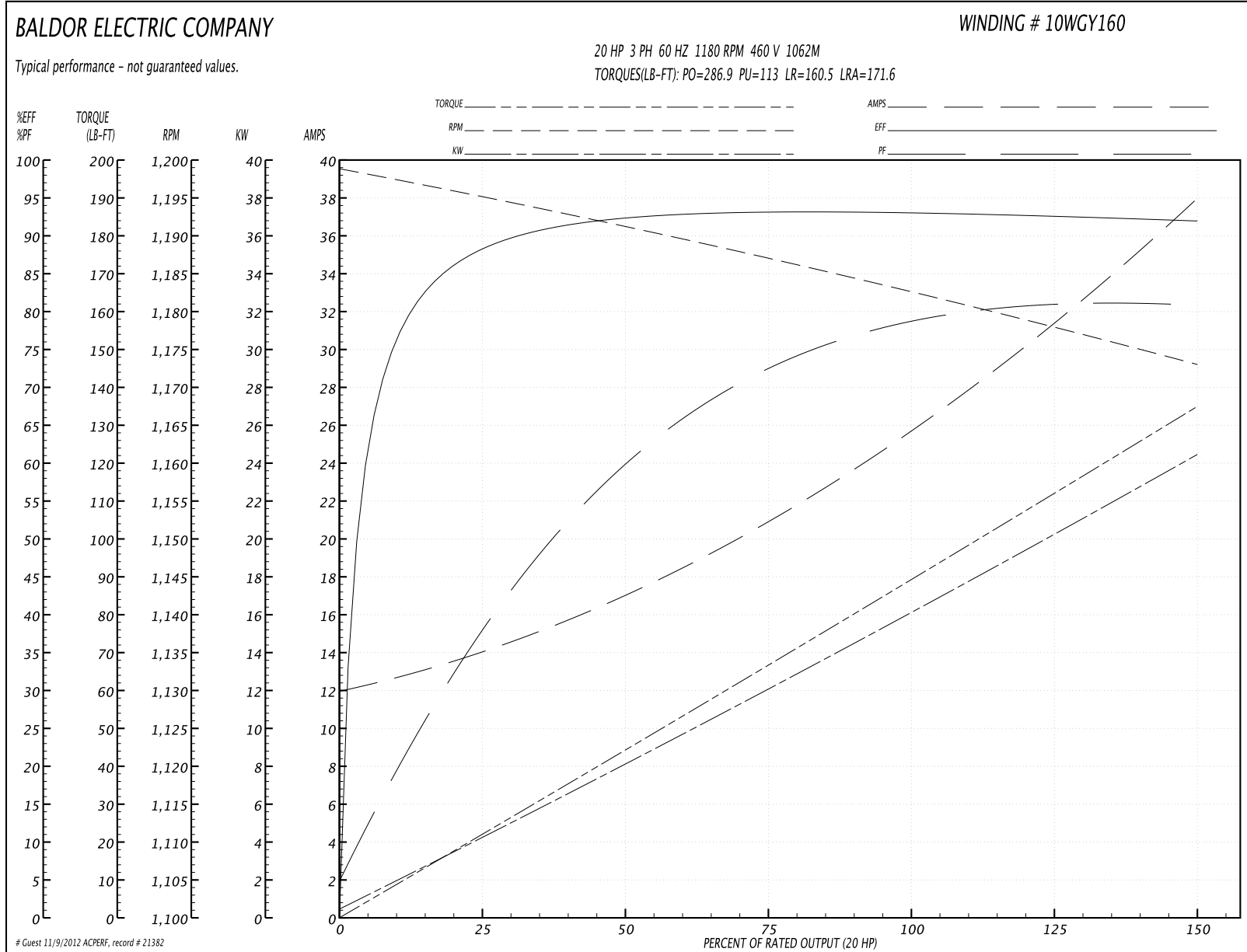

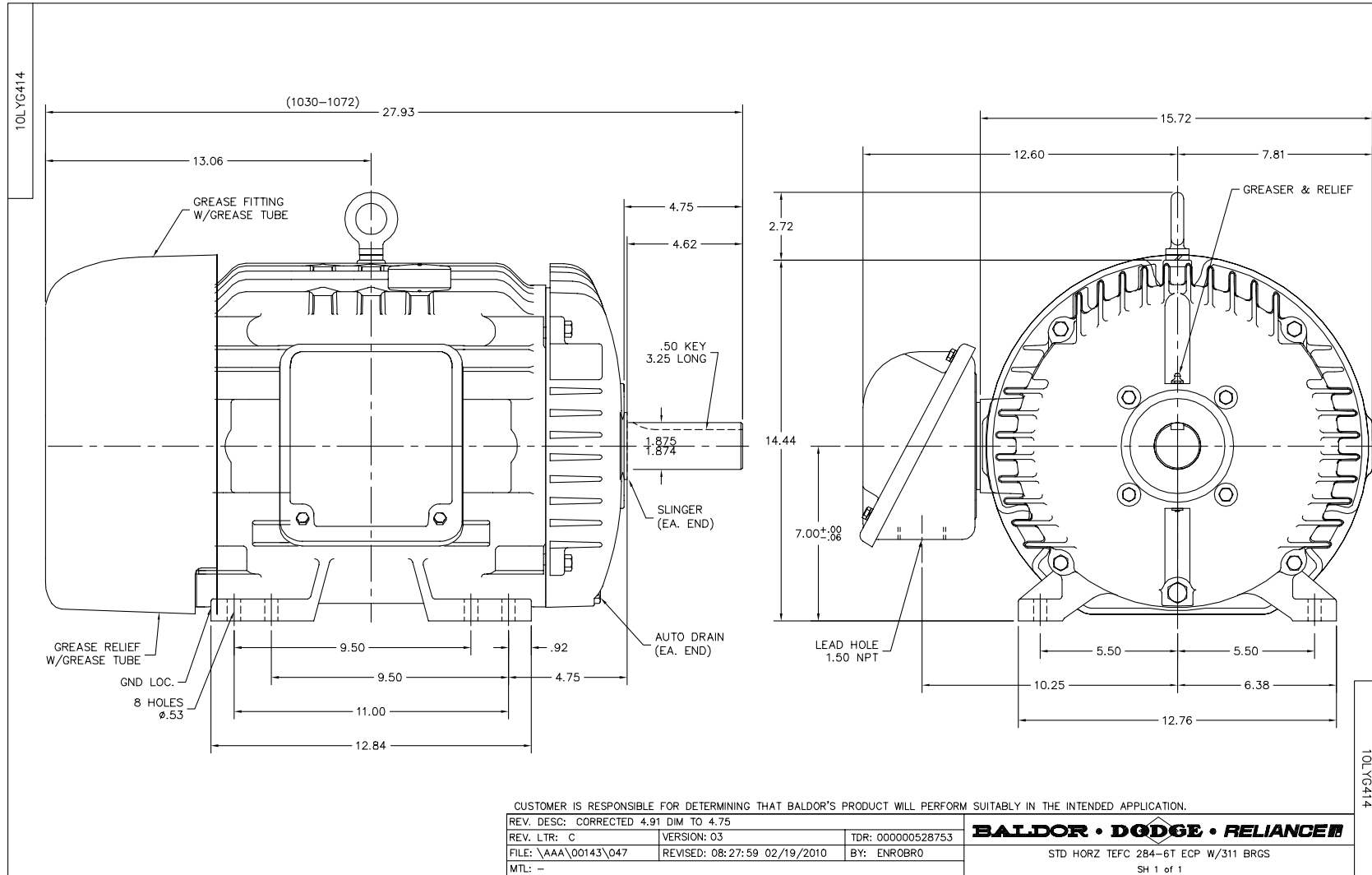

CD0006

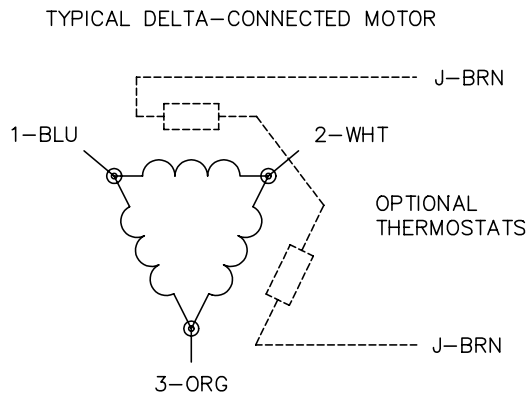

NOTES:

1. THREE LEAD MOTOR MAY BE EITHER WYE CONNECTED OR DELTA CONNECTED.
2. INTERCHANGE ANY TWO LINE LEADS TO REVERSE ROTATION.
3. OPTIONAL THERMOSTATS ARE PROVIDED WHEN SPECIFIED.
4. ACTUAL NUMBER OF INTERNAL PARALLEL CIRCUITS MAY VARY.
5. LEAD COLORS ARE OPTIONAL. LEADS MUST BE NUMBERED AS SHOWN.

| | | | |
|---|---------|------------------------|--------------|
| REV. DESC: REVISE TO SHOW OPTIONAL COLORS | | | |
| REV. LTR: D | BY: JLP | REVISED: 01/21/99 4:02 | TDR: 0171435 |
| 9000D | | FILE: AAA00005141 | MDL: - |
| | | MTL: - | |

BALDOR ELECTRIC Co.

3PH, SV, 3 LEADS, WYE OR DELTA CONNECTED

CD0006