

# **BALDOR**® • *RELIANCE*

## **Product Information Packet**

# **ECTM4115T**

**50 AIR OVERHP,1775RPM,3PH,60HZ,326T,1272**

Copyright © All product information within this document is subject to Baldor Electric Company copyright © protection, unless otherwise noted.

Part Detail							
Revision:	L	Status:	PRD/A	Change #:		Proprietary:	No
Type:	AC	Prod. Type:	1266M	Elec. Spec:	12WGX278	CD Diagram:	
Enclosure:	TEAO	Mfg Plant:		Mech. Spec:	12E837	Layout:	
Frame:	326T	Mounting:	F1	Poles:	04	Created Date:	02-09-2006
Base:	RG	Rotation:	R	Insulation:	F	Eff. Date:	11-23-2011
Leads:	9#8	Literature:		Elec. Diagram:		Replaced By:	

Nameplate NP1260E							
CAT.NO.	ECTM4115T						
SPEC.	12E837X278G1						
HP	50						
VOLTS	230/460						
AMP	114/57						
RPM	1775						
FRAME	326T	HZ	60	PH	3		
SER.F.	1.15	CODE	H	DES	B	CL	F
NEMA-NOM-EFF	94.5	PF	87				
RATING	40C AMB-CONT						
CC				USABLE AT 208V	122		
DE	6312	ODE	6311				
ENCL	TEAO	SN					
	2050 FPM AT 520CFM						

Parts List		
Part Number	Description	Quantity
SA138892	SA 12E837X278G1	1.000 EA
RA128409	RA 12E837X278G1	1.000 EA
S/P107-000-004	SUPER-E(284 FR. & UP)-CL PLANT,POLYREX E	1.000 EA
10CB1000A131P	SPL KOBX W/2.00 NPT LD & 2 .125 NPT DRAI	1.000 EA
09GS1010	GASKET, DWG, LEADWIRE SEPERATOR	1.000 EA
10XN3118K16	5/16-18 X 1" GRADE #5, STL, ZINC PLATE	4.000 EA
HW1001A31	LOCKWASHER 5/16, ZINC PLT.591 OD, .319 I	4.000 EA
HA4044A00	PLUG,PIPE 1/8 NPT PLASTIC SQUARE HEAD	2.000 EA
WD1000B16	KPA-4C BURNDY TERMINAL	1.000 EA
10XN2520K08	1/4-20 X .50 GRADE #5, STL, ZINC PLATE	1.000 EA
HW1001A25	LOCKWASHER 1/4, ZINC PLT .493 OD, .255 I	1.000 EA
12EP1107B12P	FREP MACH W/EPOXY PRIMER	1.000 EA
10XN5013K32	1/2-13 X 2.00" HEX HD GRD 5 (20051)	4.000 EA
HW1001A50	LOCKWASHER 1/2, ZINC PLT,.879 OD, .509 I	4.000 EA
HA7204	"L" SHAPE LIFTING LUG FOR 42 FRAME MOTOR	2.000 EA
HW5100A13	W4627-047 WVY WSHER	1.000 EA
12EP1106A07P	PU ENDPLATE, MACH NO GREASER,W/EPOXY PRI	1.000 EA
10XN5013K28	1/2-13 X 1.75 HEX HEAD MACH SCREW,GRAD	4.000 EA
HW1001A50	LOCKWASHER 1/2, ZINC PLT,.879 OD, .509 I	4.000 EA
HW4600B41	V-RING SLINGER 2.125 X 2.880 X 0.280	1.000 EA
10XN3118K40	5/16-18 X 2.50" HEX HD, GRADE 5	4.000 EA
10CB1503A01P	CONDUIT BOX LIPPED LID, MACH W/EPXY PRMR	1.000 EA
14GS1003	GASKET CONDUIT BOX LID, NEOP	1.000 EA
10XN2520K16	1/4-20 X 1" HX HD SCRW GRADE 5, ZINC P	4.000 EA

Parts List (continued)		
Part Number	Description	Quantity
HW1001A25	LOCKWASHER 1/4, ZINC PLT .493 OD, .255 I	4.000 EA
HW2501H33	KEY, 1/2 SQ X 3.875	1.000 EA
MJ5001A01	46-665 RED SEALER	0.031 QT
MJ5001A14	DYNAPRO SEAL, CP MOTORS VC#2508050 (603	0.030 EA
LB1115	LABEL,LIFTING DEVICE	1.000 EA
LB1002	LABEL,MARINE DUTY (ON ROLLS)	1.000 EA
LB1182	WARNING LABEL FOR MOTORS WITH EYENUTS	2.000 EA
LB5040	INSTRUCTION TAG, AC & DC	1.000 EA
HA4001A01SP	DRAIN PLUG, PLASTIC (MICRO PLAS)	1.000 EA
MJ1000A75	GREASE, POLYREX EM EXXON	0.200 LB
HA4001A01SP	DRAIN PLUG, PLASTIC (MICRO PLAS)	1.000 EA
MG1025G05	PAINT 789.201	0.080 GA
85XU0407S04	4X1/4 U DRIVE PIN STAINLESS	2.000 EA
LB1119	WARNING LABEL	1.000 EA
LB1125C02	SUPER-E (STOCK CTN LABEL SUPER-E WITH FL	4.000 EA
LB1357	ENERGY GUIDE LABEL (BOX LABEL)	1.000 SH
LC0181	CONNECTION LABEL	1.000 EA
NP1260E	SS CP SUPER-E UL CSA CC	1.000 EA
12PA1000	PACKAGING GROUP COMBINED PRINT PK1024A06	1.000 EA

**Performance Data at 460V, 60Hz, 50.0HP (Typical performance - Not guaranteed values)**

General Characteristics							
Full Load Torque:	149.0 LB-FT			Start Configuration:	DOL		
No-Load Current:	20.3 Amps			Break-Down Torque:	446.0 LB-FT		
Line-line Res. @ 25°C.:	0.118 Ohms A Ph / 0.0 Ohms B Ph			Pull-Up Torque:	210.0 LB-FT		
Temp. Rise @ Rated Load:	64 C			Locked-Rotor Torque:	229.0 LB-FT		
Temp. Rise @ S.F. Load:	77 C			Starting Current:	392.0 Amps		
Load Characteristics							
% of Rated Load	25	50	75	100	125	150	S.F.
Power Factor:	53.0	73.0	82.0	85.0	87.0	87.0	86.0
Efficiency:	91.5	94.4	94.9	94.7	94.3	93.6	94.5
Speed:	1795.0	1790.0	1784.0	1778.0	1773.0	1765.0	1775.0
Line Amperes:	24.9	34.3	45.8	58.3	71.7	86.0	65.94

Performance Graph at 460V, 60Hz, 50.0HP Typical performance - Not guaranteed values

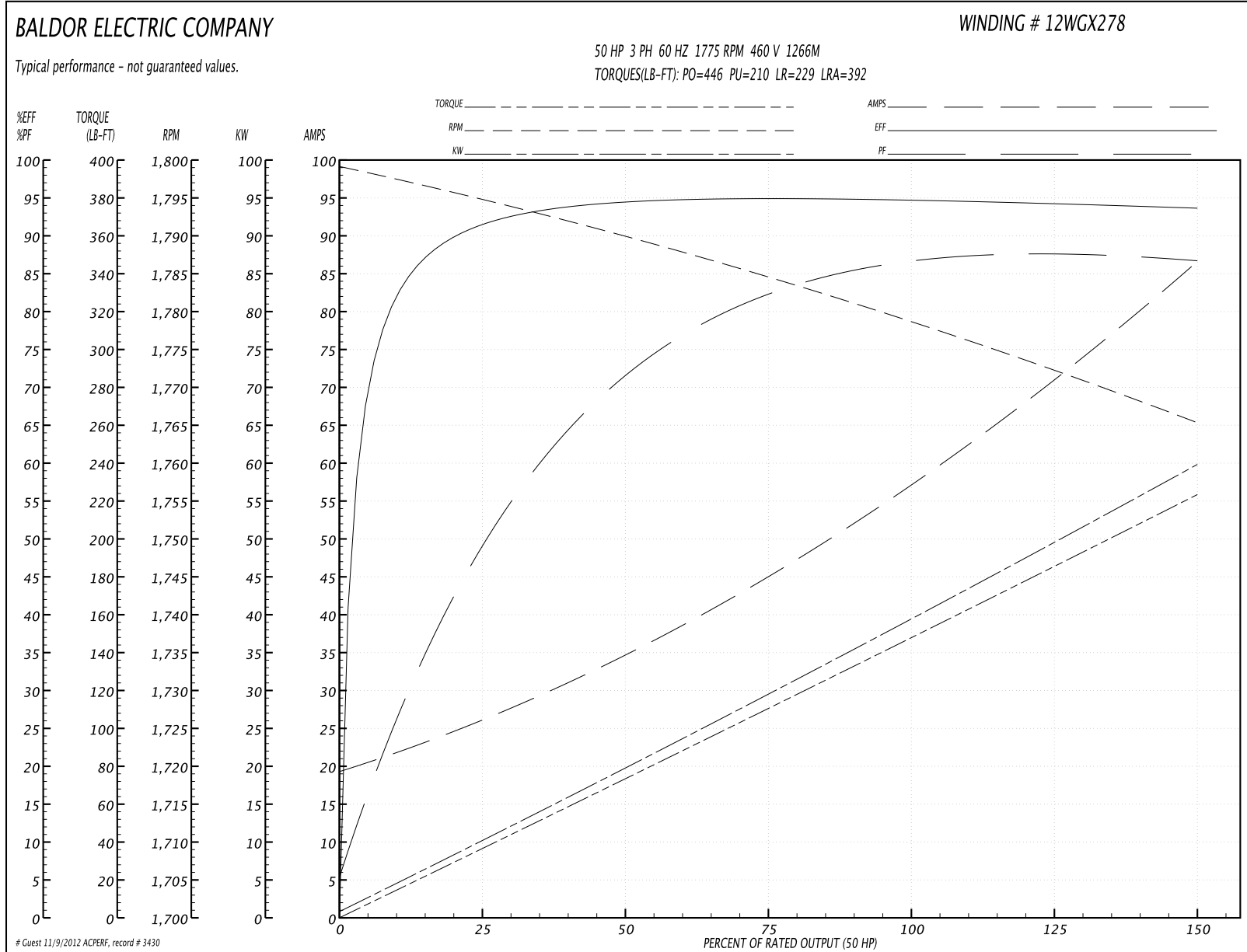

12LYE837

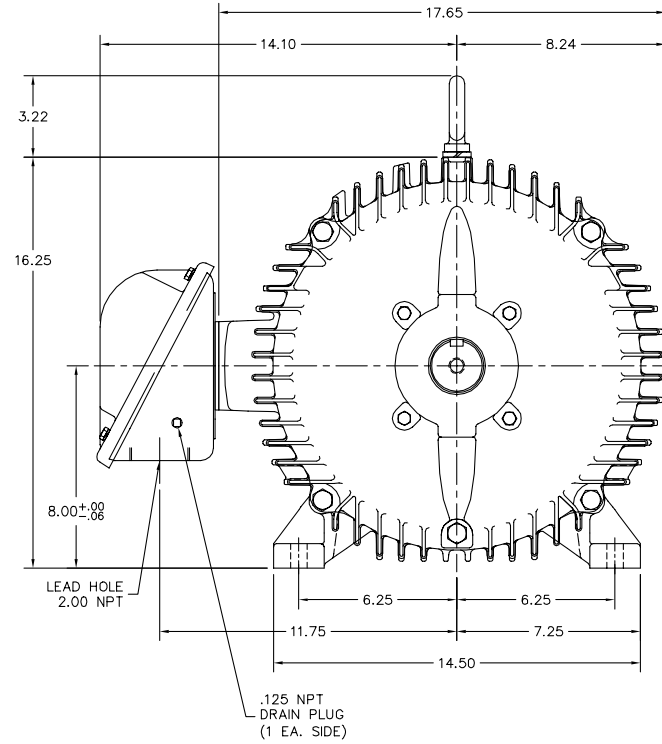
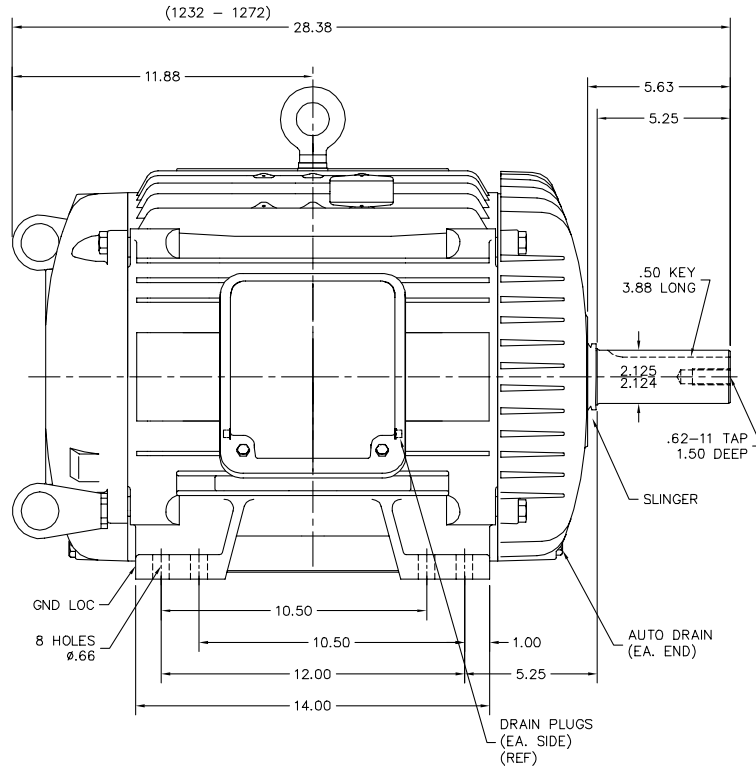

CUSTOMER ONLY NOTE: FOR VERTICAL SHAFT UP LIFTING, REMOVE EYEBOLT FROM TOP OF MOTOR AND SCREW INTO END OF SHAFT.

CUSTOMER IS RESPONSIBLE FOR DETERMINING THAT BALDOR'S PRODUCT WILL PERFORM SUITABLY IN THE INTENDED APPLICATION.

REV. DESC: CORRECT CUSTOMER NOTE		
REV. LTR: C	VERSION: 03	TDR: 000000471078
FILE: \AAA\00133\715	REVISED: 12:32:00 05/08/2009	BY: ENCARCO
MTL: -		

**BALDOR • DODGE • RELIANCE**  
 HORZ TEAO 324-6T CP COOLING TOWER MTR, SLD BRGS, VERT LIFT  
 SH 1 of 1

12LYE837

CD0180

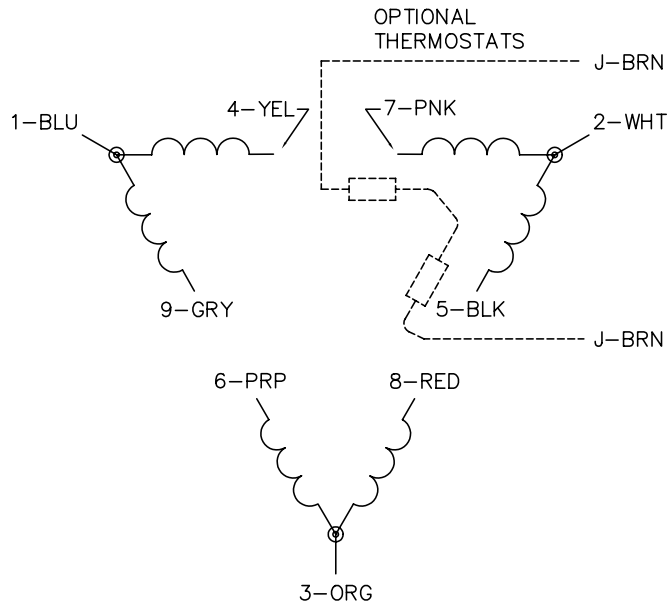

LOW VOLTAGE  
(2D)

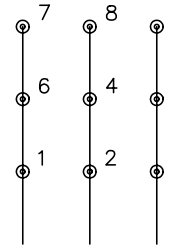

LINE

HIGH VOLTAGE  
(1D)

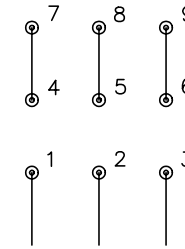

LINE

NOTES:

1. INTERCHANGE ANY TWO LINE LEADS TO REVERSE ROTATION.
2. OPTIONAL THERMOSTATS ARE PROVIDED WHEN SPECIFIED.
3. ACTUAL NUMBER OF INTERNAL PARALLEL CIRCUITS MAY BE A MULTIPLE OF THOSE SHOWN ABOVE.
4. LEAD COLORS ARE OPTIONAL. LEADS MUST ALWAYS BE NUMBERED AS SHOWN.

REV. DESC: REVISE TO SHOW OPTIONAL COLORS			
REV. LTR: C	BY: JLP	REVISED: 01/21/99 2:28	TDR: 0171435
0810D0		FILE: AAA00005148	MDL: -
		MTL: -	

**BALDOR ELECTRIC Co.**

3PH, DV, 9 LEADS, DELTA CONNECTION

CD0180