

BALDOR® • RELIANCE

Product Information Packet

EFM3714T

10HP,1770RPM,3PH,60HZ,215T,3752M,TEFC,F2

Copyright © All product information within this document is subject to Baldor Electric Company copyright © protection, unless otherwise noted.

Part Detail							
Revision:	A	Status:	PRD/A	Change #:		Proprietary:	No
Type:	AC	Prod. Type:	3752M	Elec. Spec:	37WGS518	CD Diagram:	
Enclosure:	TEFC	Mfg Plant:		Mech. Spec:	37G863	Layout:	
Frame:	215T	Mounting:	F2	Poles:	04	Created Date:	06-16-2010
Base:	RG	Rotation:	R	Insulation:	F	Eff. Date:	03-27-2012
Leads:	9#14	Literature:		Elec. Diagram:		Replaced By:	

Nameplate NP1259L									
CAT.NO.	EFM3714T								
SPEC.	37G863S518G1								
HP	10								
VOLTS	208-230/460								
AMP	25.4-24/12								
RPM	1770								
FRAME	215T	HZ	60	PH	3				
SER.F.	1.15	CODE	K	DES	A	CL	F		
NEMA-NOM-EFF	91.7	PF	85						
RATING	40C AMB-CONT								
CC	010A	USABLE AT 208V							
DE	6307	ODE	6206						
ENCL	TEFC	SN							

Parts List		
Part Number	Description	Quantity
SA199041	SA 37G863S518G1	1.000 EA
RA186392	RA 37G863S518G1	1.000 EA
37FN3002C01	EXFN, PLASTIC, 6.00 OD, 1.155 ID	1.000 EA
S/P107-000-001	SUPER E PROC'S-FS & WS PLTS-POLYREX EM G	1.000 EA
HW3200A01	3/8-16X3/4 I-BLT WELDED F/S	1.000 EA
37CB3006	37 CB CASTING W/1.38 LEAD HOLE @ 6:00	1.000 EA
37GS1000SP	GASKET, CONDUIT BOX STD., .06 THICK LEXI	1.000 EA
51XW2520A12	.25-20 X .75, TAPTITE II, HEX WSHR SLTD	2.000 EA
11XW1032G06	10-32 X .38, TAPTITE II, HEX WSHR SLTD U	1.000 EA
HW3001B01	003SS CUP WASHER, FOR #8 SCREW	1.000 EA
37EP3101A01SP	FR ENDPLATE,TEFC, 37 L&M, W/GREASER	1.000 EA
HW4500A01	1641B(ALEMITE)400 UNIV, GREASE FITT	1.000 EA
HW5100A06	W2420-025 WVY WSHR (WB)	1.000 EA
37EP3100A01SP	STD PU ENDPLATE, ENCL,37 "T"-307 BRG, W/	1.000 EA
HW4500A01	1641B(ALEMITE)400 UNIV, GREASE FITT	1.000 EA
XY3118A12	5/16-18 HEX NUT DIRECTIONAL SERRATION	4.000 EA
51XB1214A20	12-14X1.25 HXWSSLD SERTYB	1.000 EA
07FH4007SP	IEC FH W/GRSR, NOTCH @ 6:00 & 3 FAN CVR	1.000 EA
51XW1032A06	10-32 X .38, TAPTITE II, HEX WSHR SLTD S	3.000 EA
37CB4516	LIPPED LID FOR 37 FRAME NEC KOBX	1.000 EA
37GS1001SP	GASKET, CONDUIT BOX LID, .06 THICK LEXID	1.000 EA
51XW0832A07	8-32 X .44, TAPTITE II, HEX WSHR SLTD SE	4.000 EA
HW2501F21	KEY, 5/16 SQ X 2.375	1.000 EA
HA7000A02	KEY RETAINER RING, 1 1/8 DIA, 1 3/8 DIA	1.000 EA

Parts List (continued)		
Part Number	Description	Quantity
85XU0407S04	4X1/4 U DRIVE PIN STAINLESS	2.000 EA
LB1115	LABEL,LIFTING DEVICE	1.000 EA
MJ1000A75	GREASE, POLYREX EM EXXON	0.050 LB
MG1000Y03	WILKO 689.710 GOLD PAINT SUPER E	0.028 GA
HA3104A25	THRUBOLT .31-18 X 14.75	4.000 EA
LC0005E01	CONN.DIA./WARNING LABEL (LC0005/LB1119)	1.000 EA
LB1125C02	SUPER-E (STOCK CTN LABEL SUPER-E WITH FL	1.000 EA
LB1357	ENERGY GUIDE LABEL (BOX LABEL)	1.000 SH
NP1259L	ALUM SUPER-E UL CSA-EEV CC NEMA PREMIUM	1.000 EA
37PA1052	PACKAGING GROUP, 150 LB MTR 2 X 4 RUNNER	1.000 EA

Performance Data at 460V, 60Hz, 10.0HP (Typical performance - Not guaranteed values)

General Characteristics			
Full Load Torque:	29.5 LB-FT	Start Configuration:	DOL
No-Load Current:	5.49 Amps	Break-Down Torque:	134.0 LB-FT
Line-line Res. @ 25°C.:	0.93503 Ohms A Ph / 0.0 Ohms B Ph	Pull-Up Torque:	49.2 LB-FT
Temp. Rise @ Rated Load:	63 C	Locked-Rotor Torque:	68.7 LB-FT
Temp. Rise @ S.F. Load:	81 C	Starting Current:	103.0 Amps

Load Characteristics							
% of Rated Load	25	50	75	100	125	150	S.F.
Power Factor:	42.0	66.0	79.0	85.0	84.0	87.0	84.0
Efficiency:	88.9	92.1	92.4	91.8	90.3	89.0	90.9
Speed:	1793.9	1786.8	1779.7	1771.8	1762.7	1752.5	1766.0
Line Amperes:	6.14	7.63	9.58	11.9	15.4	18.1	14.0

Performance Graph at 460V, 60Hz, 10.0HP Typical performance - Not guaranteed values

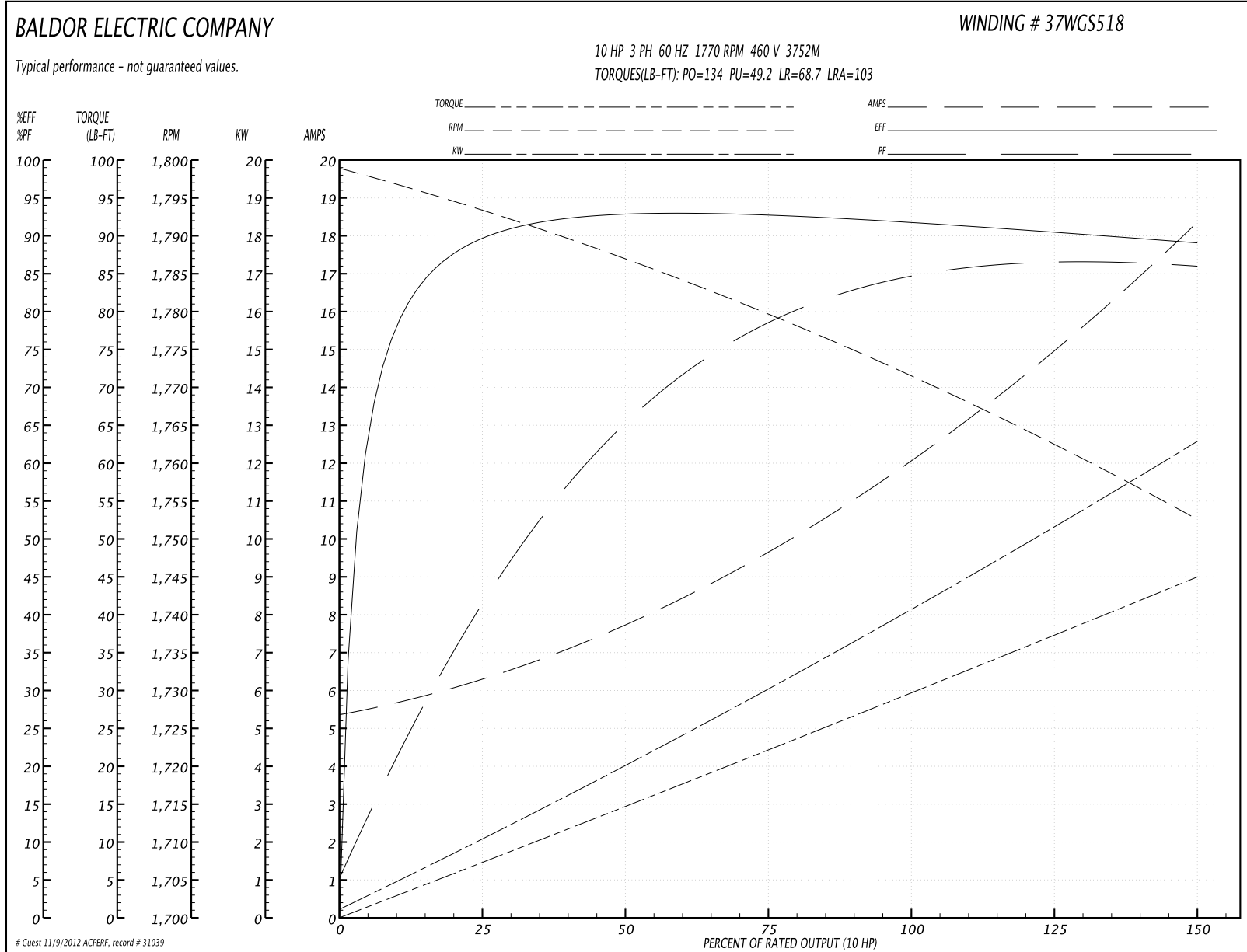

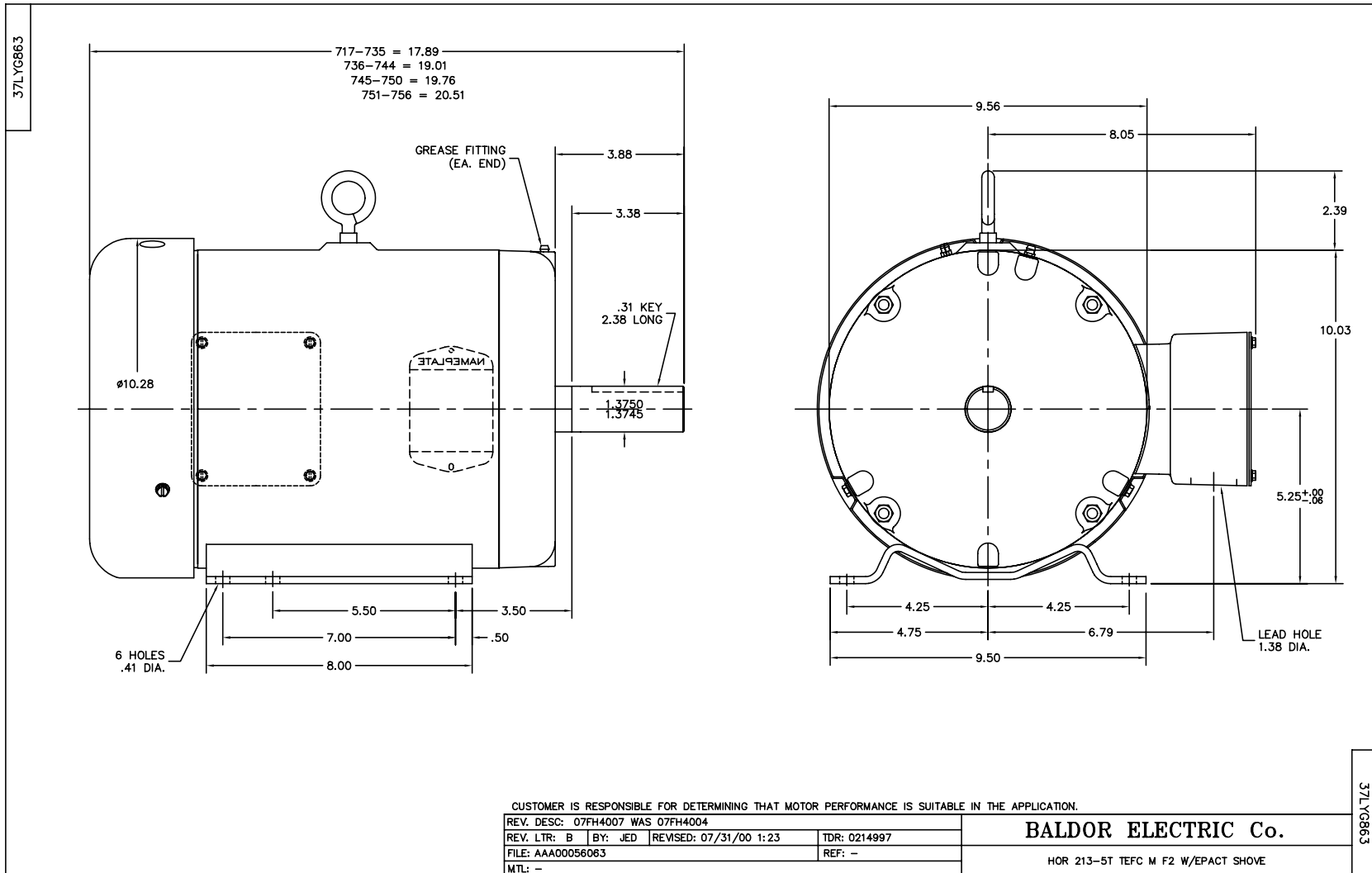

CD0005

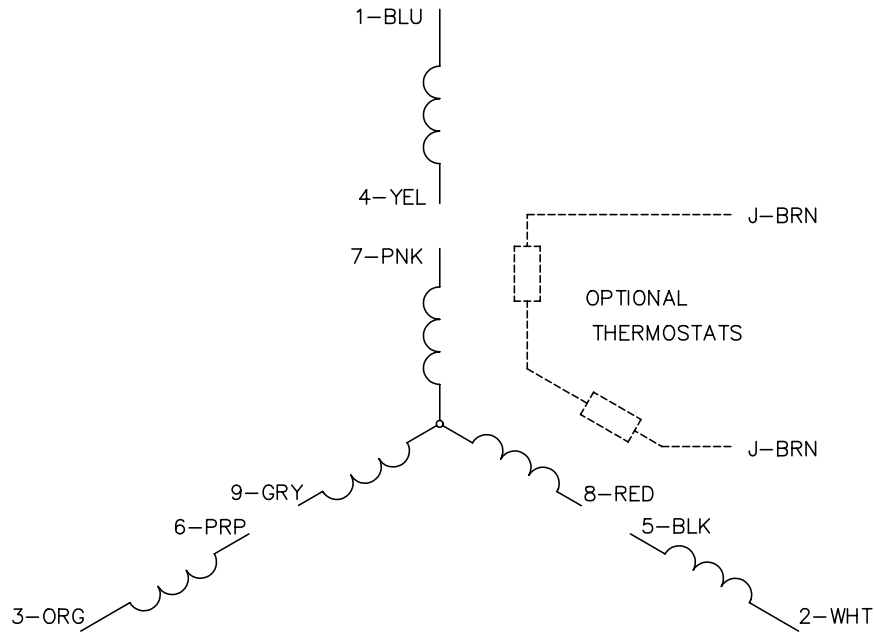

LOW VOLTAGE
(2Y)

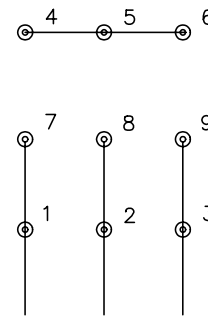

LINE

HIGH VOLTAGE
(1Y)

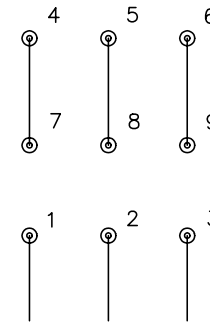

LINE

NOTES:

1. INTERCHANGE ANY TWO LINE LEADS TO REVERSE ROTATION.
2. OPTIONAL THERMOSTATS ARE PROVIDED WHEN SPECIFIED.
3. ACTUAL NUMBER OF INTERNAL PARALLEL CIRCUITS MAY BE A MULTIPLE OF THOSE SHOWN ABOVE.
4. LEAD COLORS ARE OPTIONAL. LEADS MUST ALWAYS BE NUMBERED AS SHOWN.

REV. DESC: REVISE TO SHOW OPTIONAL COLORS			
REV. LTR: E	BY: JLP	REVISED: 01/19/99 10:15	TDR: 0171435
90000		FILE: AAA00005140	MDL: -
		MTL: -	

BALDOR ELECTRIC Co.

3PH, DV, 9 LEADS

CD0005