

BALDOR® • **RELIANCE**

Product Information Packet

EHM3554T

1.5HP, 1760RPM, 3PH, 60HZ, 145T, 3526M, TEFC, F

Copyright © All product information within this document is subject to Baldor Electric Company copyright © protection, unless otherwise noted.

| Part Detail | | | | | | | |
|-------------|------|-------------|-------|----------------|----------|---------------|------------|
| Revision: | G | Status: | PRD/A | Change #: | | Proprietary: | No |
| Type: | AC | Prod. Type: | 3526M | Elec. Spec: | 35WGM493 | CD Diagram: | |
| Enclosure: | TEFC | Mfg Plant: | | Mech. Spec: | 35Z141 | Layout: | |
| Frame: | 145T | Mounting: | F1 | Poles: | 04 | Created Date: | 10-07-2010 |
| Base: | RG | Rotation: | R | Insulation: | F | Eff. Date: | 08-28-2012 |
| Leads: | 9#18 | Literature: | | Elec. Diagram: | | Replaced By: | |

Nameplate NP2094E06B03

| | | | | | | | |
|--------------|--------------|----------------|------|------|---|----|---|
| CAT.NO. | EHM3554T | | | | | | |
| SPEC. | 35Z141M493G1 | | | | | | |
| HP | 1.5 | | | | | | |
| VOLTS | 208-230/460 | | | | | | |
| AMPS | 4.5-4.4/2.2 | | | | | | |
| RPM | 1760 | | | | | | |
| FRAME | 145T | HZ | 60 | PH | 3 | | |
| SER.F. | 1.15 | CODE | L | DES | B | CL | F |
| NEMA-NOM-EFF | 86.5 | PF | 73 | | | | |
| RATING | 40C AMB-CONT | | | | | | |
| CC | 010A | USABLE AT 208V | 4.5 | | | | |
| DE | 6205 | ODE | 6203 | | | | |
| AUTO | N | MANUAL | N | NONE | Y | | |
| ENCL | TEFC | SN | | | | | |
| BLANK | | | | | | | |

| Parts List | | |
|----------------|--|----------|
| Part Number | Description | Quantity |
| SA204754 | SA 35Z141M493G1 | 1.000 EA |
| RA192000 | RA 35Z141M493G1 | 1.000 EA |
| 34FN3002B01 | EXTERNAL FAN, PLASTIC, .637/.639 HUB W/ | 1.000 EA |
| S/P107-000-001 | SUPER E PROC'S-FS & WS PLTS-POLYREX EM G | 1.000 EA |
| NS2512A01 | INSULATOR, CONDUIT BOX X | 1.000 EA |
| 35CB3009 | 35 CB CASTING W/1.09 DIA. LEAD HOLE @ 6: | 1.000 EA |
| 36GS1000SP | GASKET-CONDUIT BOX, .06 THICK #SV-330 LE | 1.000 EA |
| 51XB1016A07 | 10-16 X 7/16 HXWSSLD SERTYB | 2.000 EA |
| 11XW1032G06 | 10-32 X .38, TAPTITE II, HEX WSHR SLTD U | 1.000 EA |
| 35EP3100M01 | FREP TEFC 203 BRG W/GRSR (RAISED FH PADS | 1.000 EA |
| HW4500A19 | 1/4-28X1/4 SLOTTED PLUG F/S | 1.000 EA |
| HW5100A03SP | WAVY WASHER (W1543-017) | 1.000 EA |
| 35EP3101B90 | STD PU EP-ENCLOSED-205 BRG-W/GREASER | 1.000 EA |
| 91XN0540J08 | SCREW, 5-40 X 1/2", FHC, AS | 2.000 EA |
| HW4500A19 | 1/4-28X1/4 SLOTTED PLUG F/S | 1.000 EA |
| XY1032A02 | 10-32 HEX NUT DIRECTIONAL SERRATION | 4.000 EA |
| 51XB1214A16 | 12-14X1.00 HXWSSLD SERTYB | 1.000 EA |
| 35FH4005A84SP | IEC FH W/GRSR, NO DIMPLES W/AUTOPHERETIC | 1.000 EA |
| 51XW1032A06 | 10-32 X .38, TAPTITE II, HEX WSHR SLTD S | 3.000 EA |
| 35CB4521GX | CONDUIT BOX LID KIT | 1.000 EA |
| 51XW0832A07 | 8-32 X .44, TAPTITE II, HEX WSHR SLTD SE | 4.000 EA |
| HW2501D13SP | KEY, 3/16 SQ X 1.375 | 1.000 EA |
| HA7000A01 | KEY RETAINER 7/8" DIA SHAFT | 1.000 EA |
| MJ1000A75 | GREASE, POLYREX EM EXXON | 0.050 LB |

| Parts List (continued) | | |
|------------------------|--|----------|
| Part Number | Description | Quantity |
| MG1000G27 | PAINT- S9282E CHARCOAL GREY | 0.017 GA |
| HA3100A18 | THRUBOLT 10-32 X 9.250 | 4.000 EA |
| LB1125C02 | SUPER-E (STOCK CTN LABEL SUPER-E WITH FL | 1.000 EA |
| LB1357 | ENERGY GUIDE LABEL (BOX LABEL) | 1.000 SH |
| LC0005 | CONN.DIA.,TY M,9-LD,DUAL VOLT,REVERSING | 1.000 EA |
| NP2094E06B03 | NP LABEL W/BARCODE (PREM EFF HVAC MTR) | 1.000 EA |
| 36PA1000 | PACK GROUP W/LB5001 | 1.000 EA |

Performance Data at 460V, 60Hz, 1.5HP (Typical performance - Not guaranteed values)

| General Characteristics | | | |
|--------------------------|---------------------------------|----------------------|------------|
| Full Load Torque: | 4.47 LB-FT | Start Configuration: | DOL |
| No-Load Current: | 1.37 Amps | Break-Down Torque: | 19.2 LB-FT |
| Line-line Res. @ 25°C.: | 10.66 Ohms A Ph / 0.0 Ohms B Ph | Pull-Up Torque: | 9.4 LB-FT |
| Temp. Rise @ Rated Load: | 44 C | Locked-Rotor Torque: | 13.4 LB-FT |
| Temp. Rise @ S.F. Load: | 53 C | Starting Current: | 18.3 Amps |

| Load Characteristics | | | | | | | |
|----------------------|--------|--------|--------|--------|--------|--------|--------|
| % of Rated Load | 25 | 50 | 75 | 100 | 125 | 150 | S.F. |
| Power Factor: | 31.0 | 51.0 | 65.0 | 73.0 | 79.0 | 83.0 | 77.0 |
| Efficiency: | 75.9 | 84.5 | 86.8 | 87.1 | 86.4 | 85.4 | 86.7 |
| Speed: | 1790.6 | 1781.1 | 1770.7 | 1760.1 | 1748.1 | 1734.9 | 1753.0 |
| Line Amperes: | 1.44 | 1.61 | 1.86 | 2.19 | 2.58 | 2.98 | 2.42 |

Performance Graph at 460V, 60Hz, 1.5HP Typical performance - Not guaranteed values

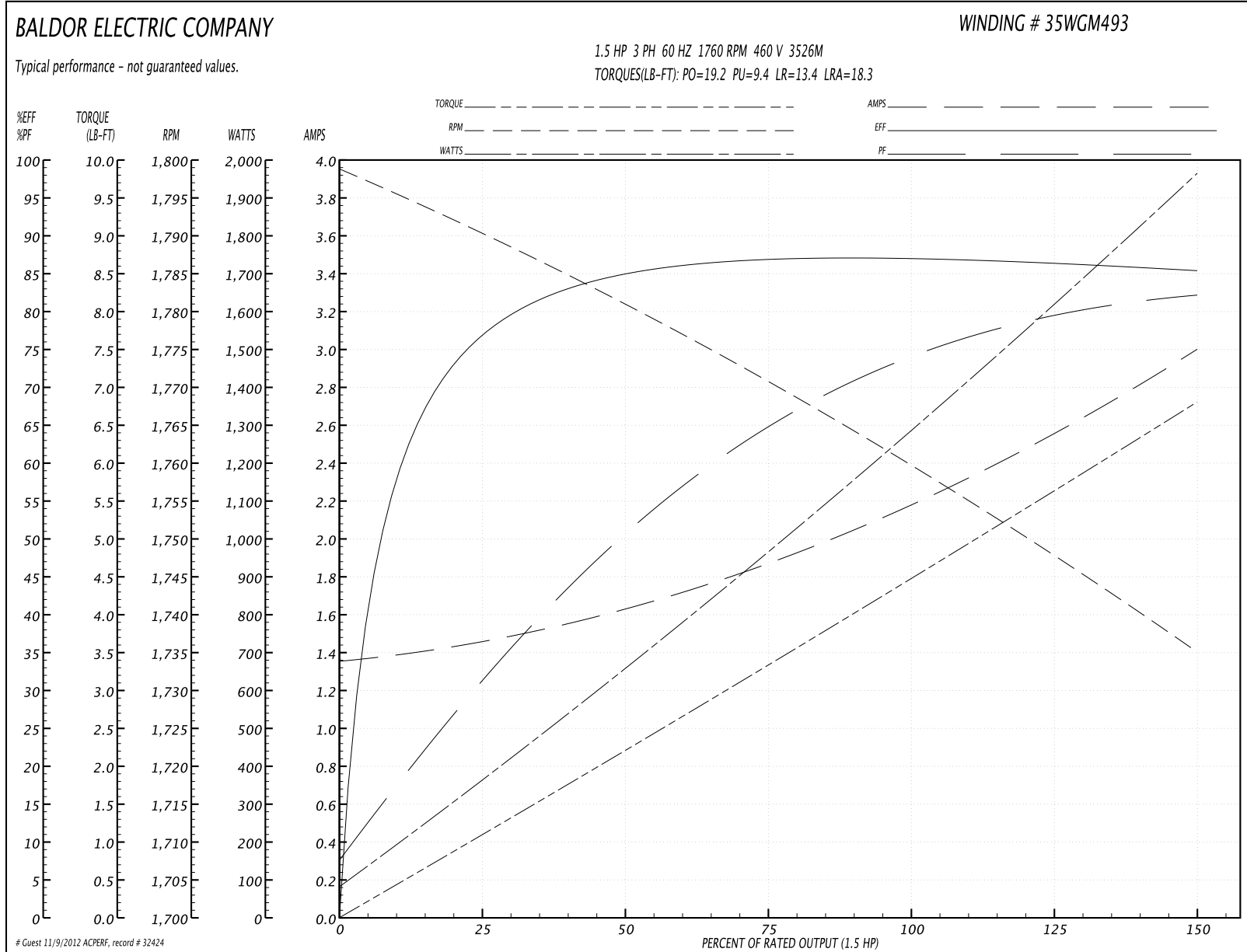

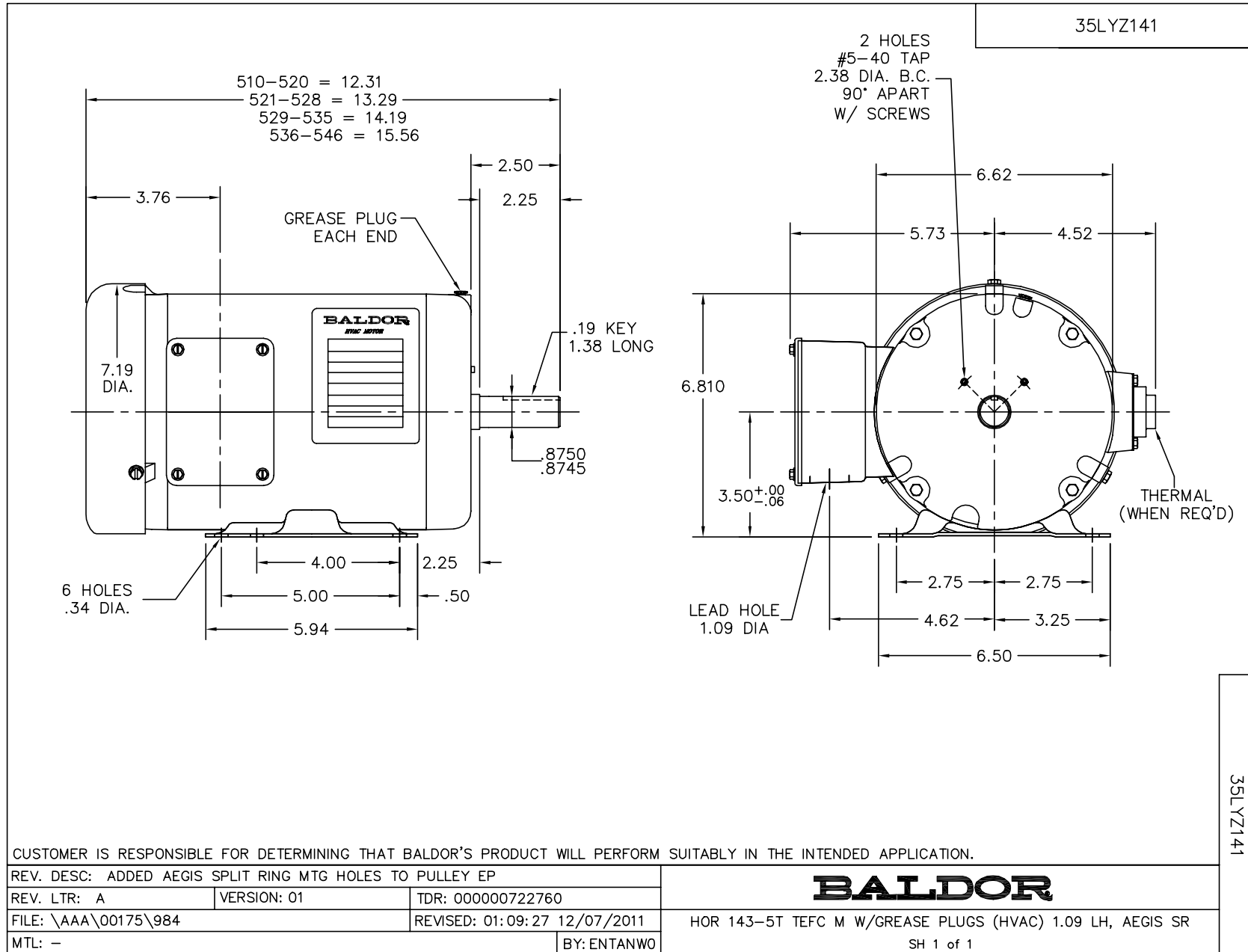

CD0005



LOW VOLTAGE
(2Y)



LINE

HIGH VOLTAGE
(1Y)

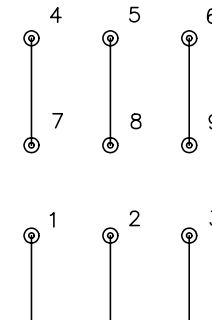

LINE

NOTES:

1. INTERCHANGE ANY TWO LINE LEADS TO REVERSE ROTATION.
2. OPTIONAL THERMOSTATS ARE PROVIDED WHEN SPECIFIED.
3. ACTUAL NUMBER OF INTERNAL PARALLEL CIRCUITS MAY BE A MULTIPLE OF THOSE SHOWN ABOVE.
4. LEAD COLORS ARE OPTIONAL. LEADS MUST ALWAYS BE NUMBERED AS SHOWN.

| | | | |
|---|---------|-------------------------|--------------|
| REV. DESC: REVISE TO SHOW OPTIONAL COLORS | | | |
| REV. LTR: E | BY: JLP | REVISED: 01/19/99 10:15 | TDR: 0171435 |
| 90000 | | FILE: AAA00005140 | MDL: - |
| | | MTL: - | |

BALDOR ELECTRIC Co.

3PH, DV, 9 LEADS

CD0005