

BALDOR® • **RELIANCE**

Product Information Packet

EJMM2535T

30HP, 1770RPM, 3PH, 60HZ, 286JM, 4052M, OPSB, F

Copyright © All product information within this document is subject to Baldor Electric Company copyright © protection, unless otherwise noted.

Part Detail							
Revision:	G	Status:	PRD/A	Change #:		Proprietary:	No
Type:	AC	Prod. Type:	4052M	Elec. Spec:	40WGW942	CD Diagram:	
Enclosure:	OPSB	Mfg Plant:		Mech. Spec:	40E211	Layout:	
Frame:	286JM	Mounting:	F1	Poles:	04	Created Date:	07-03-2009
Base:	RG	Rotation:	R	Insulation:	F	Eff. Date:	05-11-2012
Leads:	9#10	Literature:		Elec. Diagram:		Replaced By:	

Nameplate NP2138L							
CAT.NO.	EJMM2535T	P/N		ENCLOSURE	OPSB		
SPEC.	40E211W942	CC	010A	FRAME	286JM	S/N	
HP	30	CLASS	F	HZ	60		
RPM	1770	PH	3	DES	B		
VOLT	230/460	KVA-CODE	G	ODE BRG	6309	DE BRG	6312
AMP	70/35	USABLE AT 208V	74.1				
RATING	40C AMB-CONT	GREASE	POLYREX EM				
NEMA-NOM-EFF	94.1	PF	85	SER.F.	1.15		
HTR-VOLTS		HTR-AMPS		MAX. SPACE HEATER TEMP.			

Parts List		
Part Number	Description	Quantity
SA183805	SA 40E211W942	1.000 EA
RA171658	RA 40E211W942	1.000 EA
S/P107-000-006	SUPER-E(284 FR. & UP)-ZK PLANT,POLYREX E	1.000 EA
HA6017A01	CAST ADAPTOR	1.000 EA
19XW3118A12	.31-18 X .75 HEX WASHER HEAD TAPTITE II	2.000 EA
HW1001A31	LOCKWASHER 5/16, ZINC PLT.591 OD, .319 I	2.000 EA
10CB3000SP	STD KO BOX MODEL 310,312,314 MTRS W/2.00	1.000 EA
19XW3118A12	.31-18 X .75 HEX WASHER HEAD TAPTITE II	4.000 EA
WD1000B16	KPA-4C BURNDY TERMINAL	1.000 EA
51XF2520A08	SCREW, HEX SER SLT HD, ZN 1/4-20 X .50 L	1.000 EA
40EP3200A02	STD FREP OPEN 309 BRG	1.000 EA
HA1166A06	RODENT SCREEN FOR 40 ENDPLATE 40EP3200.	1.000 EA
HA1166A02	RODENT SCREEN FOR 40 ENDPLATE 40EP1300A.	1.000 EA
51XW1032A06	10-32 X .38, TAPTITE II, HEX WSHR SLTD S	4.000 EA
HW5100A11	W3917-042 WVY WSHR (WB)	1.000 EA
40EP1300A07	PU ENDPLATE, MACH	1.000 EA
51XW1032A06	10-32 X .38, TAPTITE II, HEX WSHR SLTD S	4.000 EA
10XN3118K40	5/16-18 X 2.50" HEX HD, GRADE 5	4.000 EA
HW1001A31	LOCKWASHER 5/16, ZINC PLT.591 OD, .319 I	4.000 EA
HW1001A31	LOCKWASHER 5/16, ZINC PLT.591 OD, .319 I	4.000 EA
10CB3500SP	CONDUIT BOX LID, CAST	1.000 EA
51XW2520A12	.25-20 X .75, TAPTITE II, HEX WSHR SLTD	4.000 EA
HW4600B41	V-RING SLINGER 2.125 X 2.880 X 0.280	1.000 EA
HW2501E22	KEY, 1/4 SQ X 2.500	1.000 EA

Parts List (continued)		
Part Number	Description	Quantity
LB1115	LABEL,LIFTING DEVICE	1.000 EA
LB5040	INSTRUCTION TAG, AC & DC	1.000 EA
HW4500A03	GREASE FITTING, .125 NPT 1610(ALEMITE) 8	1.000 EA
HW4500A17	317400 ALEMITE GREASE RELIEF	1.000 EA
HA4051A00	PLASTIC CAP FOR GREASE FITTING	1.000 EA
MJ1000A75	GREASE, POLYREX EM EXXON	0.050 LB
HW4500A03	GREASE FITTING, .125 NPT 1610(ALEMITE) 8	1.000 EA
HW4500A17	317400 ALEMITE GREASE RELIEF	1.000 EA
HA4051A00	PLASTIC CAP FOR GREASE FITTING	1.000 EA
MG1000Y03	WILKO 689.710 GOLD PAINT SUPER E	0.070 GA
85XU0407A04	#4-7 X 1/4 DRIVE PIN	4.000 EA
40AD2002A01	LEXAN BAFFLE 40 FR OPEN	1.000 EA
40AD2002A01	LEXAN BAFFLE 40 FR OPEN	1.000 EA
HA3113A11	THRUBOLT 3/8 - 16 X 18.375	4.000 EA
LB1125C02	SUPER-E (STOCK CTN LABEL SUPER-E WITH FL	4.000 EA
LB1357	ENERGY GUIDE LABEL (BOX LABEL)	1.000 SH
LC0005E01	CONN.DIA./WARNING LABEL (LC0005/LB1119)	1.000 EA
NP2138L	ALUM SUPER-E UL CSA-EEV PREM CC (300	1.000 EA
40PA1000	PACKAGING GROUP	1.000 EA

Performance Data at 460V, 60Hz, 30.0HP (Typical performance - Not guaranteed values)							
General Characteristics							
Full Load Torque:	88.9 LB-FT			Start Configuration:	DOL		
No-Load Current:	13.32 Amps			Break-Down Torque:	272.0 LB-FT		
Line-line Res. @ 25°C.:	0.237 Ohms A Ph / 0.0 Ohms B Ph			Pull-Up Torque:	127.0 LB-FT		
Temp. Rise @ Rated Load:	31 C			Locked-Rotor Torque:	149.0 LB-FT		
Temp. Rise @ S.F. Load:	40 C			Starting Current:	223.6 Amps		
Load Characteristics							
% of Rated Load	25	50	75	100	125	150	S.F.
Power Factor:	50.0	72.0	82.0	85.0	87.0	87.0	86.0
Efficiency:	90.3	93.6	94.2	94.1	93.6	92.7	93.8
Speed:	1792.0	1785.0	1777.0	1769.0	1761.0	1752.0	1765.0
Line Amperes:	15.5	20.75	27.37	34.9	43.0	52.1	39.7

Performance Graph at 460V, 60Hz, 30.0HP Typical performance - Not guaranteed values

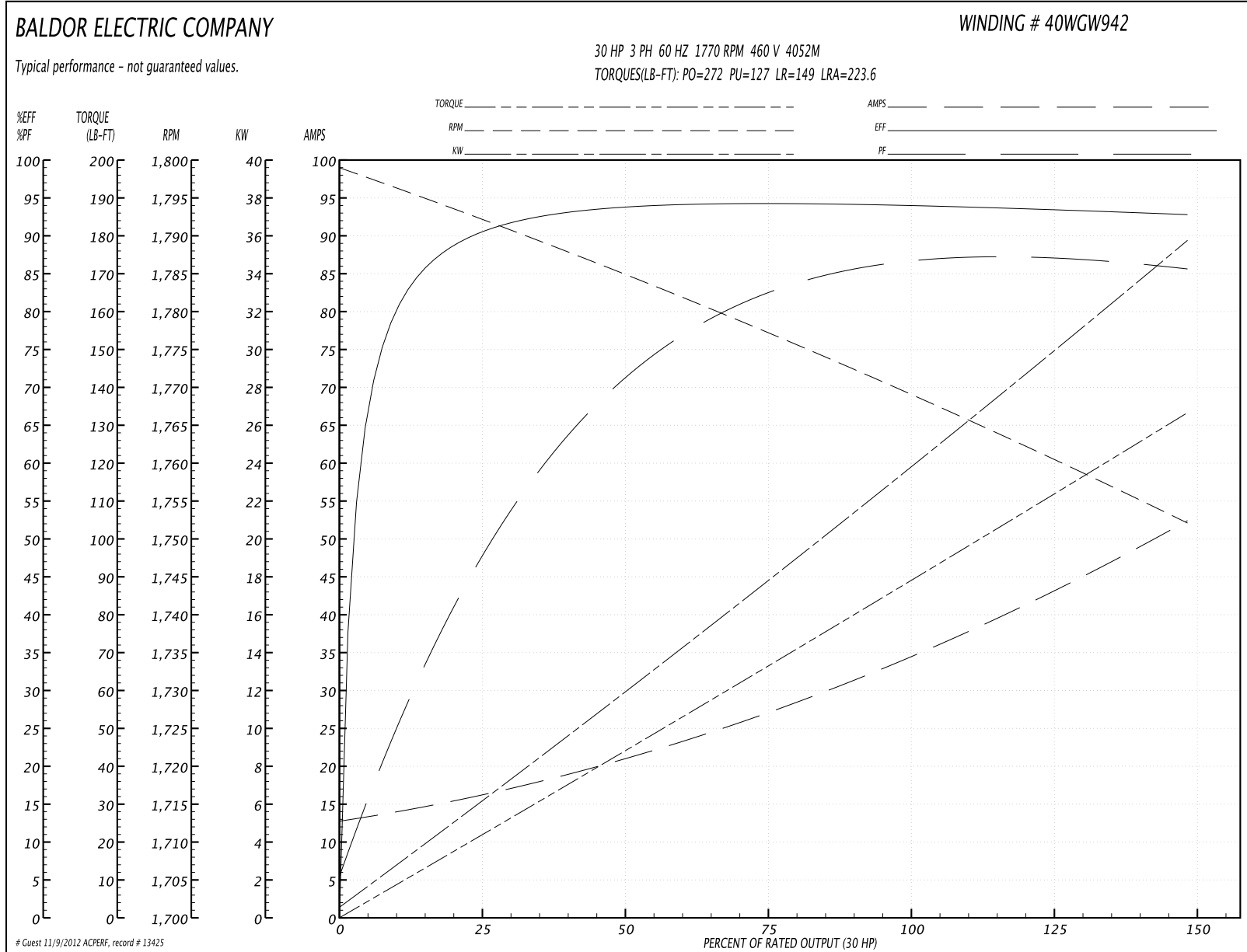

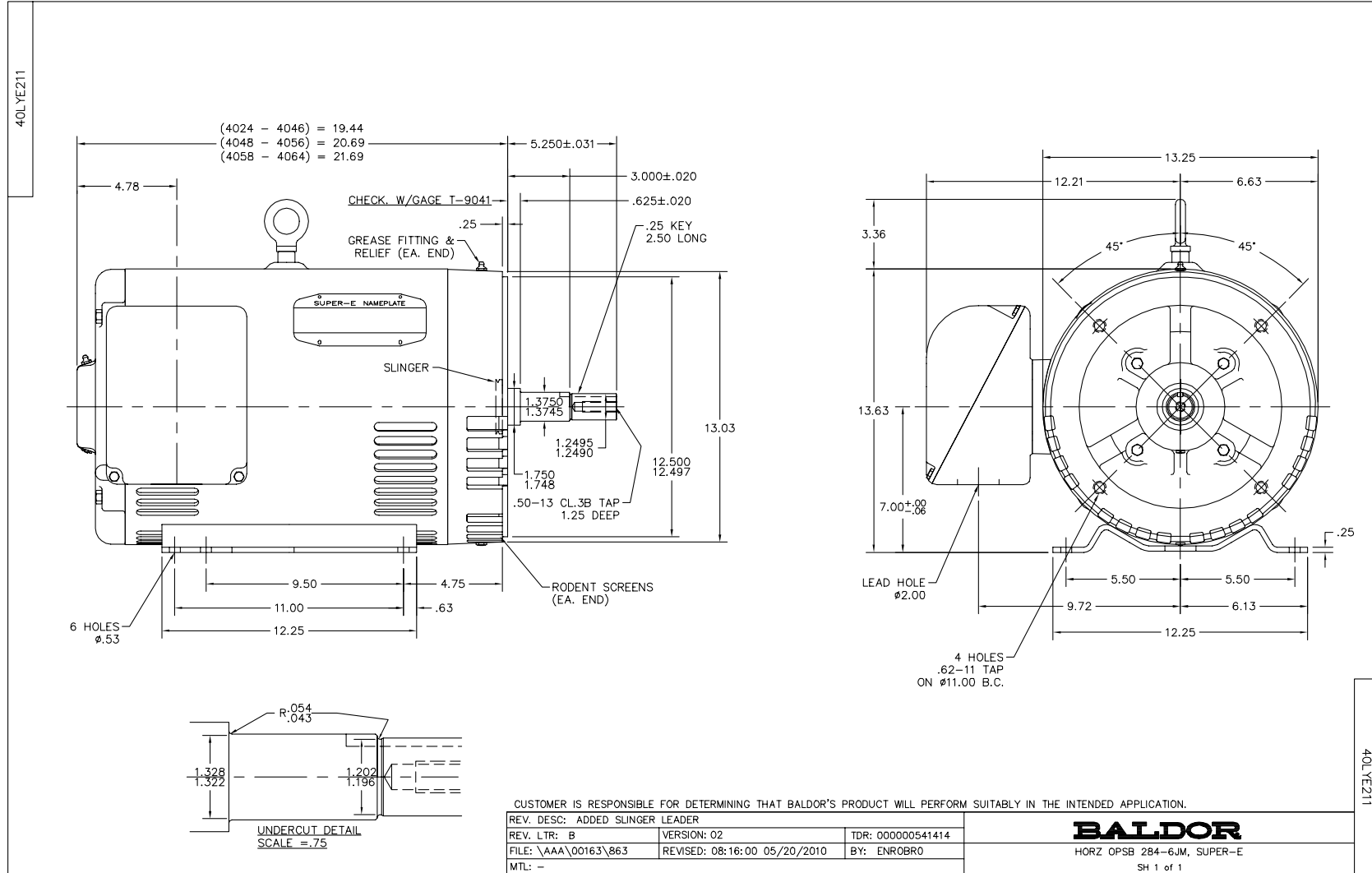

CD0005



LOW VOLTAGE (2Y)

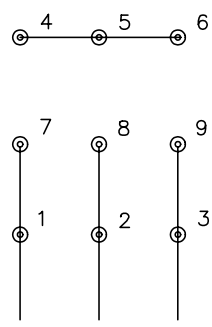

HIGH VOLTAGE (1Y)

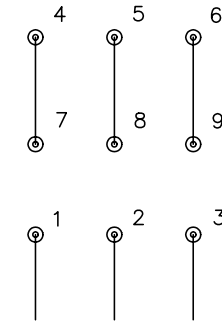

NOTES:

1. INTERCHANGE ANY TWO LINE LEADS TO REVERSE ROTATION.
2. OPTIONAL THERMOSTATS ARE PROVIDED WHEN SPECIFIED.
3. ACTUAL NUMBER OF INTERNAL PARALLEL CIRCUITS MAY BE A MULTIPLE OF THOSE SHOWN ABOVE.
4. LEAD COLORS ARE OPTIONAL. LEADS MUST ALWAYS BE NUMBERED AS SHOWN.

REV. DESC: REVISE TO SHOW OPTIONAL COLORS			
REV. LTR: E	BY: JLP	REVISED: 01/19/99 10:15	TDR: 0171435
90000		FILE: AAA00005140	MDL: -
		MTL: -	

BALDOR ELECTRIC Co.

3PH, DV, 9 LEADS

CD0005