

BALDOR® • RELIANCE

Product Information Packet

EJMM3157T-G

2HP, 1750RPM, 3PH, 60HZ, 145JM, 3525M, OPSB, F1

Copyright © All product information within this document is subject to Baldor Electric Company copyright © protection, unless otherwise noted.

Part Detail									
Revision:	A	Status:	PRD/A	Change #:		Proprietary:	No		
Type:	AC	Prod. Type:	3525M	Elec. Spec:	35WGM496	CD Diagram:			
Enclosure:	OPSB	Mfg Plant:		Mech. Spec:	35Z929	Layout:			
Frame:	145JM	Mounting:	F1	Poles:	04	Created Date:	12-06-2011		
Base:	RG	Rotation:	R	Insulation:	H	Eff. Date:	08-13-2012		
Leads:	9#18	Literature:		Elec. Diagram:		Replaced By:			
Nameplate NP1259L									
CAT.NO.	EJMM3157T-G								
SPEC.	35Z929M496G1								
HP	2								
VOLTS	230/460								
AMP	5.8/2.9								
RPM	1750								
FRAME	145JM	HZ	60			PH	3		
SER.F.	1.15	CODE	K			DES	B	CL	H
NEMA-NOM-EFF	86.5	PF	76						
RATING	40C AMB-CONT								
CC	010A	USABLE AT 208V	5.8						
DE	6206	ODE	6203						
ENCL	OPSB	SN							

Parts List		
Part Number	Description	Quantity
SA235513	SA 35Z929M496G1	1.000 EA
RA222476	RA 35Z929M496G1	1.000 EA
S/P107-000-001	SUPER E PROC'S-FS & WS PLTS-POLYREX EM G	1.000 EA
NS2512A01	INSULATOR, CONDUIT BOX X	1.000 EA
35CB3009	35 CB CASTING W/1.09 DIA. LEAD HOLE @ 6:	1.000 EA
51XB1016A07	10-16 X 7/16 HXWSSLD SERTYB	2.000 EA
11XW1032G06	10-32 X .38, TAPTITE II, HEX WSHR SLTD U	1.000 EA
35EP3201A01	STD FR ENDPLATE-OPEN-203 BRG W/GREASER	1.000 EA
HW4500A01	1641B(ALEMITE)400 UNIV, GREASE FITT	1.000 EA
HA1100A03	SCREEN, RODENT	1.000 EA
51XT1032A04	10-32X1/4 HX WA SL SR TYT (F/S)	4.000 EA
HW1000A10	#10 FLAT WASHER (SAE)	4.000 EA
HW5100A03SP	WAVY WASHER (W1543-017)	1.000 EA
BP5325A01	AEGIS SH GRD ASSY W/RETAINER RING	1.000 EA
35EP3401A03	PU ENDPLATE -OPEN W/SCREENS & GREASER W/	1.000 EA
HW4500A01	1641B(ALEMITE)400 UNIV, GREASE FITT	1.000 EA
HA1102A08	RODENT SCREEN 35 OPEN FACE MTD	1.000 EA
51XT1032A04	10-32X1/4 HX WA SL SR TYT (F/S)	4.000 EA
51XN1032A20	10-32 X 1 1/4 HX WS SL SR	2.000 EA
35CB4521	35 LIPPED CB LID (GALV & PHOSPH)	1.000 EA
51XW0832A07	8-32 X .44, TAPTITE II, HEX WSHR SLTD SE	4.000 EA
HA1005A02SP	SLINGER, OD 2.00, ID 1.14, 206 BRG,	1.000 EA
HW2501D13SP	KEY, 3/16 SQ X 1.375	1.000 EA
HA7000A01	KEY RETAINER 7/8" DIA SHAFT	1.000 EA

Parts List (continued)		
Part Number	Description	Quantity
85XU0407S04	4X1/4 U DRIVE PIN STAINLESS	2.000 EA
LB1459	AEGIS SGR LABEL "AEGISLBL-100"	1.000 EA
HW1000A10	#10 FLAT WASHER (SAE)	4.000 EA
MJ1000A75	GREASE, POLYREX EM EXXON	0.050 LB
MG1000Y03	WILKO 689.710 GOLD PAINT SUPER E	0.017 GA
HA3100A15	THRUBOLT 10-32 X 8.375	4.000 EA
35AD2005A01	BAFFLE PLATE,MOD 35-SLTD BAND MTRS TDR	2.000 EA
LC0005E01	CONN.DIA./WARNING LABEL (LC0005/LB1119)	1.000 EA
LB1357	ENERGY GUIDE LABEL (BOX LABEL)	1.000 SH
LB1125C02	SUPER-E (STOCK CTN LABEL SUPER-E WITH FL	1.000 EA
NP1259L	ALUM SUPER-E UL CSA-EEV CC NEMA PREMIUM	1.000 EA
36PA1000	PACK GROUP W/LB5001	1.000 EA

Performance Data at 460V, 60Hz, 2.0HP (Typical performance - Not guaranteed values)

General Characteristics							
Full Load Torque:	6.03 LB-FT			Start Configuration:	DOL		
No-Load Current:	1.68 Amps			Break-Down Torque:	22.9 LB-FT		
Line-line Res. @ 25°C.:	8.81 Ohms A Ph / 0.0 Ohms B Ph			Pull-Up Torque:	11.4 LB-FT		
Temp. Rise @ Rated Load:	39 C			Locked-Rotor Torque:	15.6 LB-FT		
Temp. Rise @ S.F. Load:	47 C			Starting Current:	21.9 Amps		
Load Characteristics							
% of Rated Load	25	50	75	100	125	150	S.F.
Power Factor:	35.0	54.0	68.0	76.0	80.0	84.0	78.0
Efficiency:	76.7	84.5	86.6	86.7	85.9	84.4	86.2
Speed:	1789.0	1779.0	1768.0	1757.0	1743.0	1728.0	1749.0
Line Amperes:	1.79	2.05	2.41	2.88	3.4	3.98	3.19

Performance Graph at 460V, 60Hz, 2.0HP Typical performance - Not guaranteed values

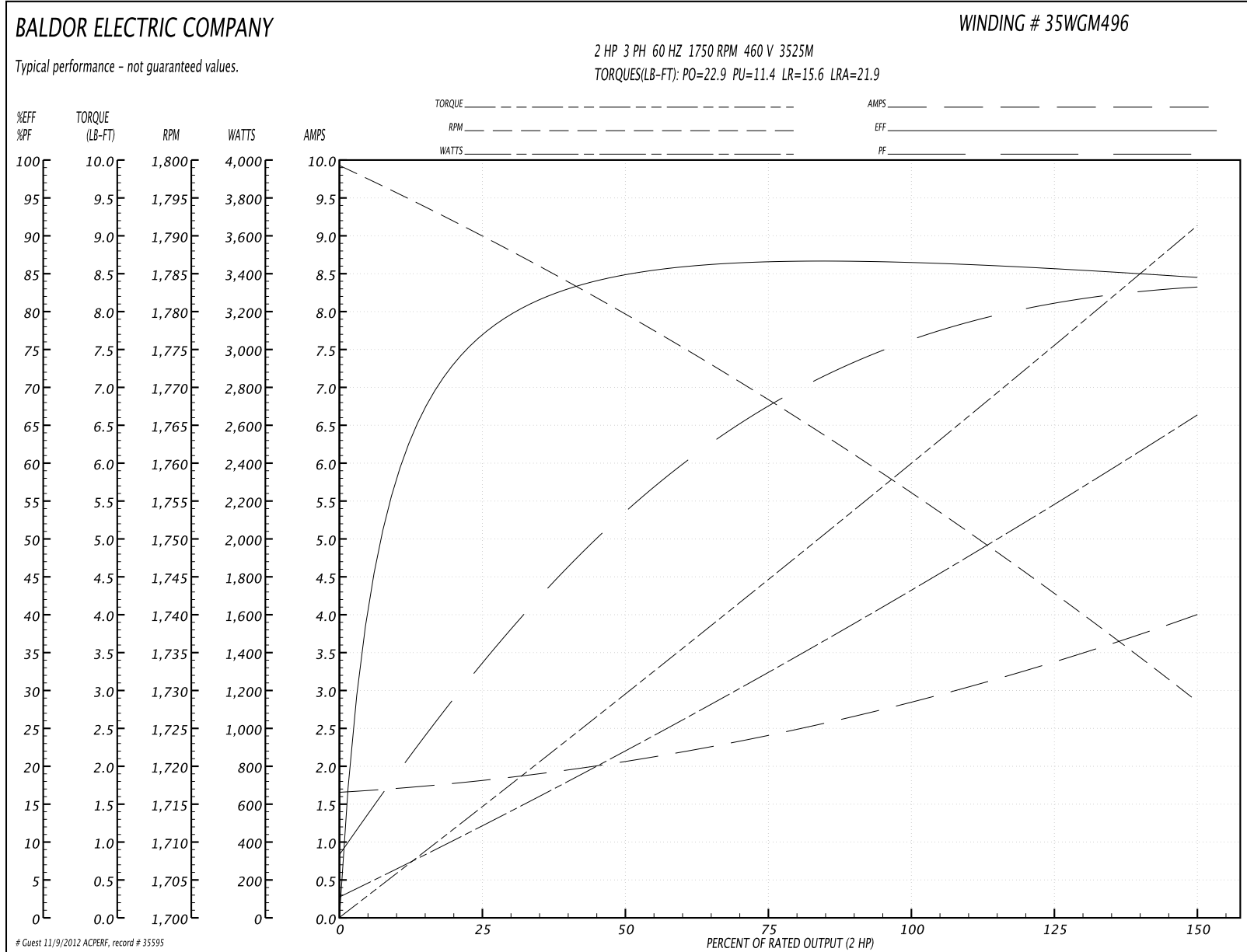

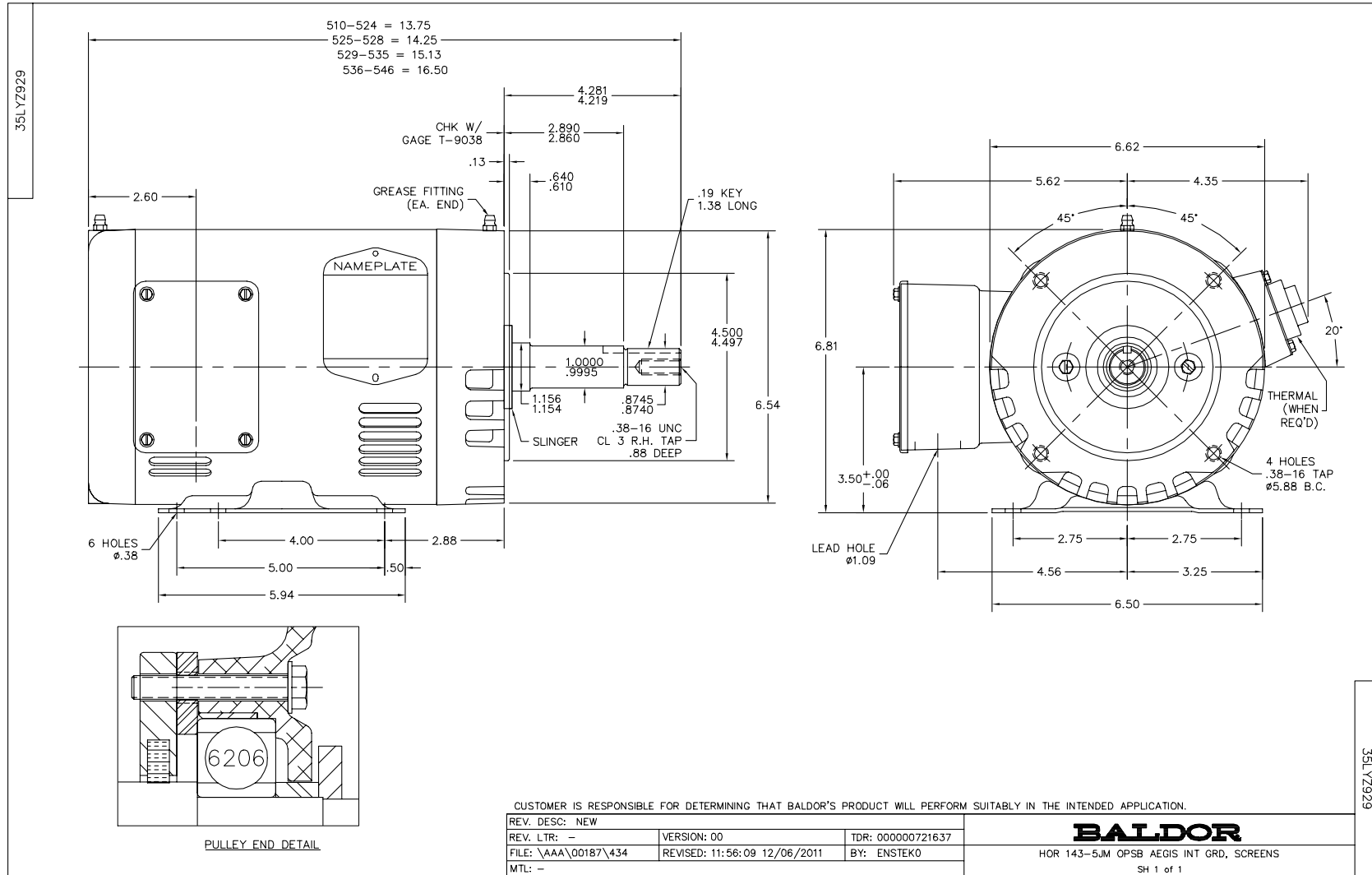

CD0005



LOW VOLTAGE
(2Y)

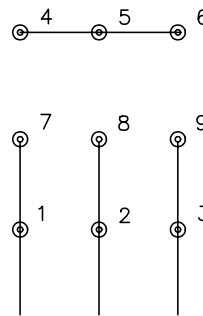

LINE

HIGH VOLTAGE
(1Y)

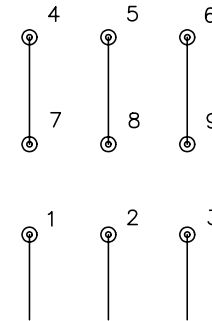

LINE

NOTES:

1. INTERCHANGE ANY TWO LINE LEADS TO REVERSE ROTATION.
2. OPTIONAL THERMOSTATS ARE PROVIDED WHEN SPECIFIED.
3. ACTUAL NUMBER OF INTERNAL PARALLEL CIRCUITS MAY BE A MULTIPLE OF THOSE SHOWN ABOVE.
4. LEAD COLORS ARE OPTIONAL. LEADS MUST ALWAYS BE NUMBERED AS SHOWN.

REV. DESC: REVISE TO SHOW OPTIONAL COLORS			
REV. LTR: E	BY: JLP	REVISED: 01/19/99 10:15	TDR: 0171435
90000		FILE: AAA00005140	MDL: -
		MTL: -	

BALDOR ELECTRIC Co.

3PH, DV, 9 LEADS

CD0005