

BALDOR® • *RELIANCE*

Product Information Packet

EJMM3615T-G

5HP, 1750RPM, 3PH, 60HZ, 184JM, 3642M, TEFC, F1

Copyright © All product information within this document is subject to Baldor Electric Company copyright © protection, unless otherwise noted.

Part Detail									
Revision:	-	Status:	PRD/A	Change #:		Proprietary:	No		
Type:	AC	Prod. Type:	3642M	Elec. Spec:	36WGS268	CD Diagram:			
Enclosure:	TEFC	Mfg Plant:		Mech. Spec:	36N542	Layout:			
Frame:	184JM	Mounting:	F1	Poles:	04	Created Date:	12-12-2011		
Base:	RG	Rotation:	R	Insulation:	H	Eff. Date:	12-13-2011		
Leads:	9#16	Literature:		Elec. Diagram:		Replaced By:			
Nameplate NP1259L									
CAT.NO.	EJMM3615T-G								
SPEC.	36N542S268G1								
HP	5								
VOLTS	208-230/460								
AMP	13.9-13.4/6.7								
RPM	1750								
FRAME	184JM	HZ	60	PH	3				
SER.F.	1.15	CODE	J	DES	B	CL	H		
NEMA-NOM-EFF	89.5	PF	78						
RATING	40C AMB-CONT								
CC	010A	USABLE AT 208V	13.9						
DE	6207	ODE	6205						
ENCL	TEFC	SN							

Parts List		
Part Number	Description	Quantity
SA235582	SA 36N542S268G1	1.000 EA
RA222543	RA 36N542S268G1	1.000 EA
36FN3000C01SP	EXFN, PLASTIC, 5.25 OD, .912 ID	1.000 EA
S/P107-000-001	SUPER E PROC'S-FS & WS PLTS-POLYREX EM G	1.000 EA
36CB3004	36 CB CASTING W/1.09 DIA LEAD HOLE @ 6:0	1.000 EA
36GS1000SP	GASKET-CONDUIT BOX, .06 THICK #SV-330 LE	1.000 EA
51XB1016A08	10-16X 1/2HXWSSLD SERTYB	2.000 EA
11XW1032G06	10-32 X .38, TAPTITE II, HEX WSHR SLTD U	1.000 EA
HW3001B01	003SS CUP WASHER, FOR #8 SCREW	1.000 EA
36EP3104A04	FR ENDPLATE, MACH	1.000 EA
HW4500A01	1641B(ALEMITE)400 UNIV, GREASE FITT	1.000 EA
HW4500A17	317400 ALEMITE GREASE RELIEF	1.000 EA
HW5100A05	WVY WSHR F/205 & 304 BRGS	1.000 EA
BP5316A01	AEGIS SH GRD ASSY W/RETAINER RING	1.000 EA
36EP3405T03	PUEP ENCL 207 BRG T'SLV,GRSR,REL,DRAIN	1.000 EA
HW4500A01	1641B(ALEMITE)400 UNIV, GREASE FITT	1.000 EA
HW4500A17	317400 ALEMITE GREASE RELIEF	1.000 EA
10XN2520A24	1/4-20X 1 1/2 HEX HD X	4.000 EA
HW1001A25	LOCKWASHER 1/4, ZINC PLT .493 OD, .255 I	4.000 EA
51XB1214A16	12-14X1.00 HXWSSLD SERTYB	1.000 EA
36FH4009A103	IEC FH GREASER W/AUTOPHERETIC PRIMER	1.000 EA
51XW1032A06	10-32 X .38, TAPTITE II, HEX WSHR SLTD S	3.000 EA
36CB4516	36 LIPPED CB LID	1.000 EA
37GS1001SP	GASKET, CONDUIT BOX LID, .06 THICK LEXID	1.000 EA

Parts List (continued)		
Part Number	Description	Quantity
51XW0832A07	8-32 X .44, TAPTITE II, HEX WSHR SLTD SE	4.000 EA
HA1005A07SP	SLINGER, OD 2.25, ID 1.344, 307 BRG	1.000 EA
HW2501D13SP	KEY, 3/16 SQ X 1.375	1.000 EA
HA7000A01	KEY RETAINER 7/8" DIA SHAFT	1.000 EA
85XU0407S04	4X1/4 U DRIVE PIN STAINLESS	2.000 EA
LB1459	AEGIS SGR LABEL "AEGISLBL-100"	1.000 EA
MJ1000A75	GREASE, POLYREX EM EXXON	0.050 LB
MG1000Y03	WILKO 689.710 GOLD PAINT SUPER E	0.022 GA
HA3101A28	THRUBOLT 1/4-20 X 12.500 OHIO ROD	4.000 EA
LC0005E01	CONN.DIA./WARNING LABEL (LC0005/LB1119)	1.000 EA
LB1125C02	SUPER-E (STOCK CTN LABEL SUPER-E WITH FL	1.000 EA
LB1357	ENERGY GUIDE LABEL (BOX LABEL)	1.000 SH
NP1259L	ALUM SUPER-E UL CSA-EEV CC NEMA PREMIUM	1.000 EA
36PA1001	PACKAGING GROUP	1.000 EA

Performance Data at 460V, 60Hz, 5.0HP (Typical performance - Not guaranteed values)

General Characteristics							
Full Load Torque:	14.9 LB-FT			Start Configuration:	DOL		
No-Load Current:	3.24 Amps			Break-Down Torque:	52.2 LB-FT		
Line-line Res. @ 25°C.:	2.27 Ohms A Ph / 0.0 Ohms B Ph			Pull-Up Torque:	31.5 LB-FT		
Temp. Rise @ Rated Load:	71 C			Locked-Rotor Torque:	34.9 LB-FT		
Temp. Rise @ S.F. Load:	87 C			Starting Current:	49.1 Amps		
Load Characteristics							
% of Rated Load	25	50	75	100	125	150	S.F.
Power Factor:	39.0	60.0	72.0	78.0	83.0	83.0	81.0
Efficiency:	85.0	89.7	90.6	89.6	88.6	87.0	89.0
Speed:	1789.0	1776.0	1762.0	1750.0	1733.0	1714.0	1740.0
Line Amperes:	3.55	4.31	5.43	6.65	7.94	9.64	7.42

Performance Graph at 460V, 60Hz, 5.0HP Typical performance - Not guaranteed values

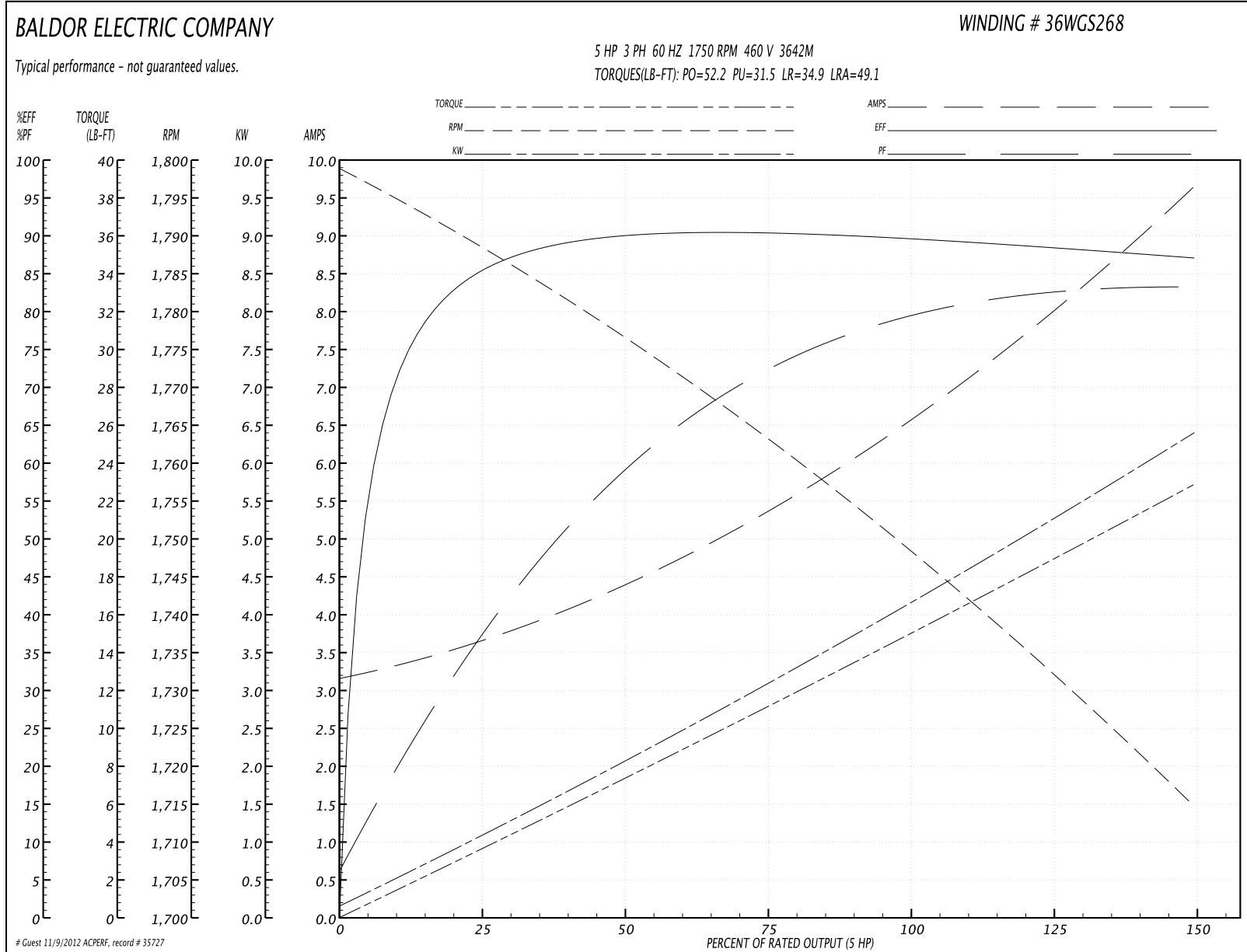

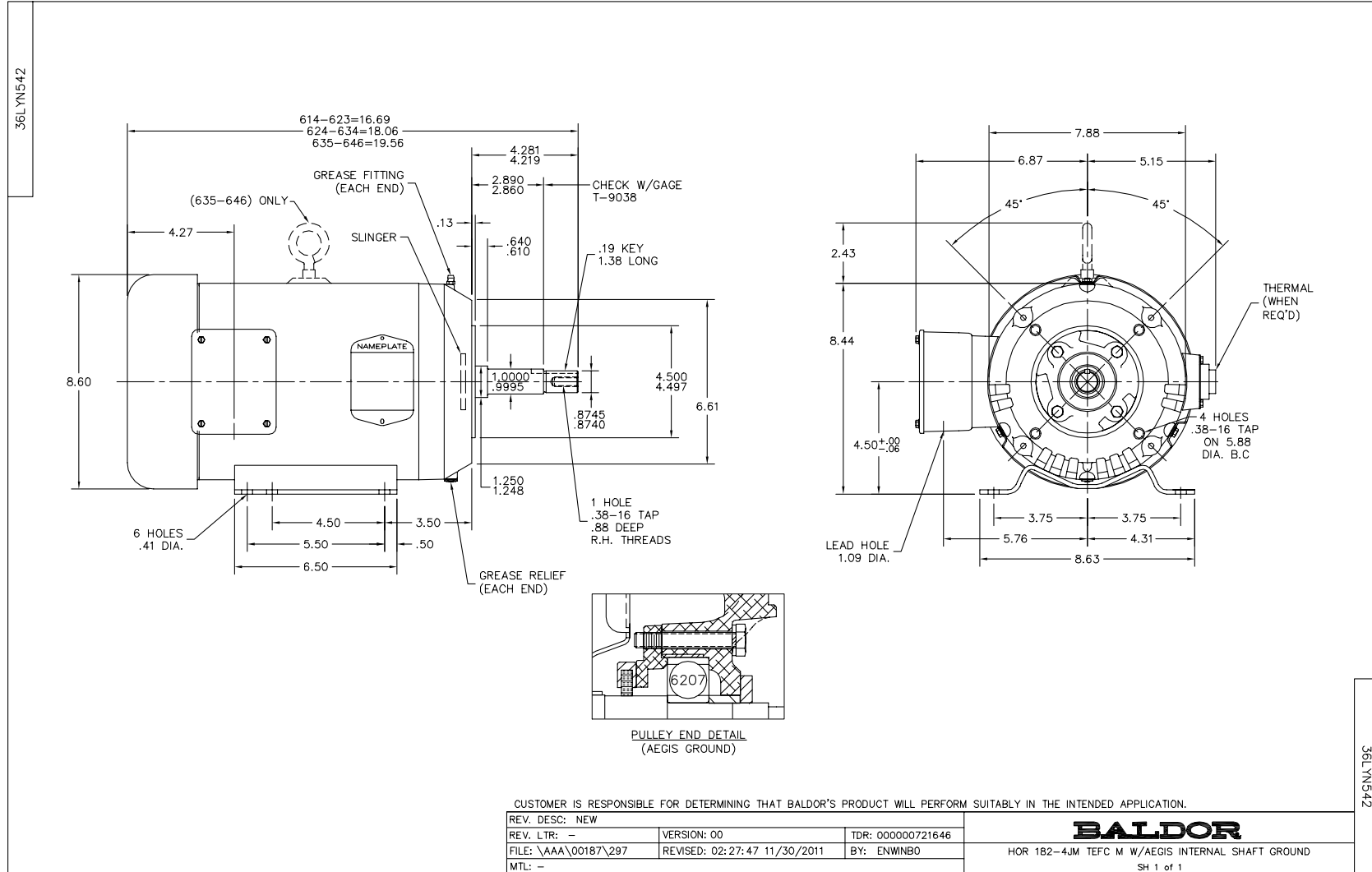

CD0005



LOW VOLTAGE
(2Y)



LINE

HIGH VOLTAGE
(1Y)

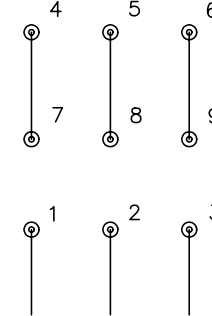

LINE

NOTES:

1. INTERCHANGE ANY TWO LINE LEADS TO REVERSE ROTATION.
2. OPTIONAL THERMOSTATS ARE PROVIDED WHEN SPECIFIED.
3. ACTUAL NUMBER OF INTERNAL PARALLEL CIRCUITS MAY BE A MULTIPLE OF THOSE SHOWN ABOVE.
4. LEAD COLORS ARE OPTIONAL. LEADS MUST ALWAYS BE NUMBERED AS SHOWN.

REV. DESC: REVISE TO SHOW OPTIONAL COLORS			
REV. LTR: E	BY: JLP	REVISED: 01/19/99 10:15	TDR: 0171435
90000		FILE: AAA00005140	MDL: -
		MTL: -	

BALDOR ELECTRIC Co.

3PH, DV, 9 LEADS

CD0005