

BALDOR® • *RELIANCE*

Product Information Packet

EM2333T

15HP,1765RPM,3PH,60HZ,254T,0944M,TEFC,F1

Copyright © All product information within this document is subject to Baldor Electric Company copyright © protection, unless otherwise noted.

Part Detail							
Revision:	-	Status:	PRD/A	Change #:		Proprietary:	No
Type:	AC	Prod. Type:	0944M	Elec. Spec:	09WZ910	CD Diagram:	
Enclosure:	TEFC	Mfg Plant:		Mech. Spec:	09P11	Layout:	
Frame:	254T	Mounting:	F1	Poles:	04	Created Date:	11-07-2012
Base:	RG	Rotation:	R	Insulation:	F	Eff. Date:	11-08-2012
Leads:	9#12	Literature:		Elec. Diagram:		Replaced By:	

Nameplate NP1259L									
CAT.NO.	EM2333T								
SPEC.	09P011Z910G1								
HP	15								
VOLTS	230/460								
AMP	36.2/18.1								
RPM	1765								
FRAME	254T	HZ	60	PH	3				
SER.F.	1.15	CODE	H	DES	A	CL	F		
NEMA-NOM-EFF	92.4	PF	83						
RATING	40C AMB-CONT								
CC	010A	USABLE AT 208V	38						
DE	6309	ODE	6208						
ENCL	TEFC	SN							

Parts List		
Part Number	Description	Quantity
SA253898	SA 09P011Z910G1	1.000 EA
RA240710	RA 09P011Z910G1	1.000 EA
S/P107-000-005	SUPER-E PROC'S(254/6 FR.) ZK PLANT - POL	1.000 EA
HW1002A63	WASHER, 5/8 HI-COLLAR SPRLOCKWASHER	1.000 EA
09CB3002SP	CB W/1.38 LEAD HOLE FOR 37, 39, 307 & 30	1.000 EA
09GS1000SP	GASKET-CONDUIT BOX, 1/16 THICK LEXIDE	1.000 EA
10XN2520K12	1/4-20 X.75 GRD 5	2.000 EA
HW1001A25	LOCKWASHER 1/4, ZINC PLT .493 OD, .255 I	2.000 EA
WD1000B17	KPA-8C BURNDY TERMINAL	1.000 EA
11XW1032G06	10-32 X .38, TAPTITE II, HEX WSHR SLTD U	1.000 EA
09EP1100A194	ENDPLATE, MACH	1.000 EA
XY3816A12	3/8-16 FINISHED NUT	4.000 EA
HW1001A38	LOCKWASHER 3/8, ZINC PLT .688 OD, .382 I	4.000 EA
HW5100A08	W3118-035 WVY WSHR (WB)	1.000 EA
10XN2520K28	1/4-20 X 1.75" HX HD SCRWGRADE 5, ZINC P	2.000 EA
HW1001A25	LOCKWASHER 1/4, ZINC PLT .493 OD, .255 I	2.000 EA
09EP1101A136	PU ENDPLATE, MACH	1.000 EA
HW4600B44SP	V-RING SLINGER 1.500 X 2.290 X 0.280	1.000 EA
10XN2520K36	1/4-20 X 2.25" HX HD SCRWGRADE 5, ZINC P	4.000 EA
HW1001A25	LOCKWASHER 1/4, ZINC PLT .493 OD, .255 I	4.000 EA
HA3113A02	THRUBOLT 3/8-16 X 16.750	4.000 EA
HW1001A38	LOCKWASHER 3/8, ZINC PLT .688 OD, .382 I	4.000 EA
09FH4000SP	FAN COVER, STAMPED	1.000 EA
HA2081A05	SPACER TUBE, 309 FAN HSG, 2.00 LONG	4.000 EA

Parts List (continued)		
Part Number	Description	Quantity
XY3816A12	3/8-16 FINISHED NUT	4.000 EA
HW1001A38	LOCKWASHER 3/8, ZINC PLT .688 OD, .382 I	4.000 EA
09CB3501SP	CONDUIT BOX LID FOR 09CB3001 & 09CB3002	1.000 EA
09GS1013SP	09 GS FOR 09CB3501 LID - LEXIDE	1.000 EA
51XW2520A12	.25-20 X .75, TAPTITE II, HEX WSHR SLTD	2.000 EA
HW2501G25	KEY, 3/8 SQ X 2.875	1.000 EA
LB1115	LABEL,LIFTING DEVICE	1.000 EA
LB5040	INSTRUCTION TAG, AC & DC	1.000 EA
HA4051A00	PLASTIC CAP FOR GREASE FITTING	1.000 EA
HW4500A05	1669B ALEM/UNIV860 GR FTG X	1.000 EA
HW4500A17	317400 ALEMITE GREASE RELIEF	1.000 EA
HA4066A01	PUSH IN T-DRAIN FITTING (BLACK)	1.000 EA
MJ1000A75	GREASE, POLYREX EM EXXON	0.080 LB
HA4051A00	PLASTIC CAP FOR GREASE FITTING	1.000 EA
HW4500A03	GREASE FITTING, .125 NPT 1610(ALEMITE) 8	1.000 EA
HW4500A17	317400 ALEMITE GREASE RELIEF	1.000 EA
HA4066A01	PUSH IN T-DRAIN FITTING (BLACK)	1.000 EA
09FN3001D01SP	EXTERNAL FAN, PLASTIC	1.000 EA
HW2500A25	WOODRUFF KEY USA #1008 #BLOW CARBON STEE	1.000 EA
51XB1214A20	12-14X1.25 HXWSSLD SERTYB	1.000 EA
MG1000Y03	WILKO 689.710 GOLD PAINT SUPER E	0.050 GA
85XU0407A04	#4-7 X 1/4 DRIVE PIN	2.000 EA
LB1119	WARNING LABEL	1.000 EA
LB1125C02	SUPER-E (STOCK CTN LABEL SUPER-E WITH FL	4.000 EA

Parts List (continued)		
Part Number	Description	Quantity
LB1357	ENERGY GUIDE LABEL (BOX LABEL)	1.000 SH
LC0005	CONN.DIA.,TY M,9-LD,DUAL VOLT,REVERSING	1.000 EA
NP1259L	ALUM SUPER-E UL CSA-EEV CC NEMA PREMIUM	1.000 EA
09PA1000	PACKAGING GROUP COMBINED PRINT	1.000 EA

Accessories		
Part Number	Description	Multiplier
09-1309	C FACE KIT (kit may require RB3001A01)	A8

Performance Data at 460V, 60Hz, 15.0HP (Typical performance - Not guaranteed values)

General Characteristics			
Full Load Torque:	44.5 LB-FT	Start Configuration:	DOL
No-Load Current:	7.56 Amps	Break-Down Torque:	153.0 LB-FT
Line-line Res. @ 25°C.:	0.59555 Ohms A Ph / 0.0 Ohms B Ph	Pull-Up Torque:	69.5 LB-FT
Temp. Rise @ Rated Load:	54 C	Locked-Rotor Torque:	86.5 LB-FT
Temp. Rise @ S.F. Load:	67 C	Starting Current:	127.0 Amps

Load Characteristics							
% of Rated Load	25	50	75	100	125	150	S.F.
Power Factor:	45.0	69.0	79.0	83.0	85.0	87.0	84.0
Efficiency:	88.2	92.2	92.7	92.4	91.5	90.4	91.9
Speed:	1791.3	1783.1	1774.0	1765.2	1754.6	1743.1	1759.0
Line Amperes:	8.62	11.0	14.5	18.2	22.6	26.9	20.8

Performance Graph at 460V, 60Hz, 15.0HP Typical performance - Not guaranteed values

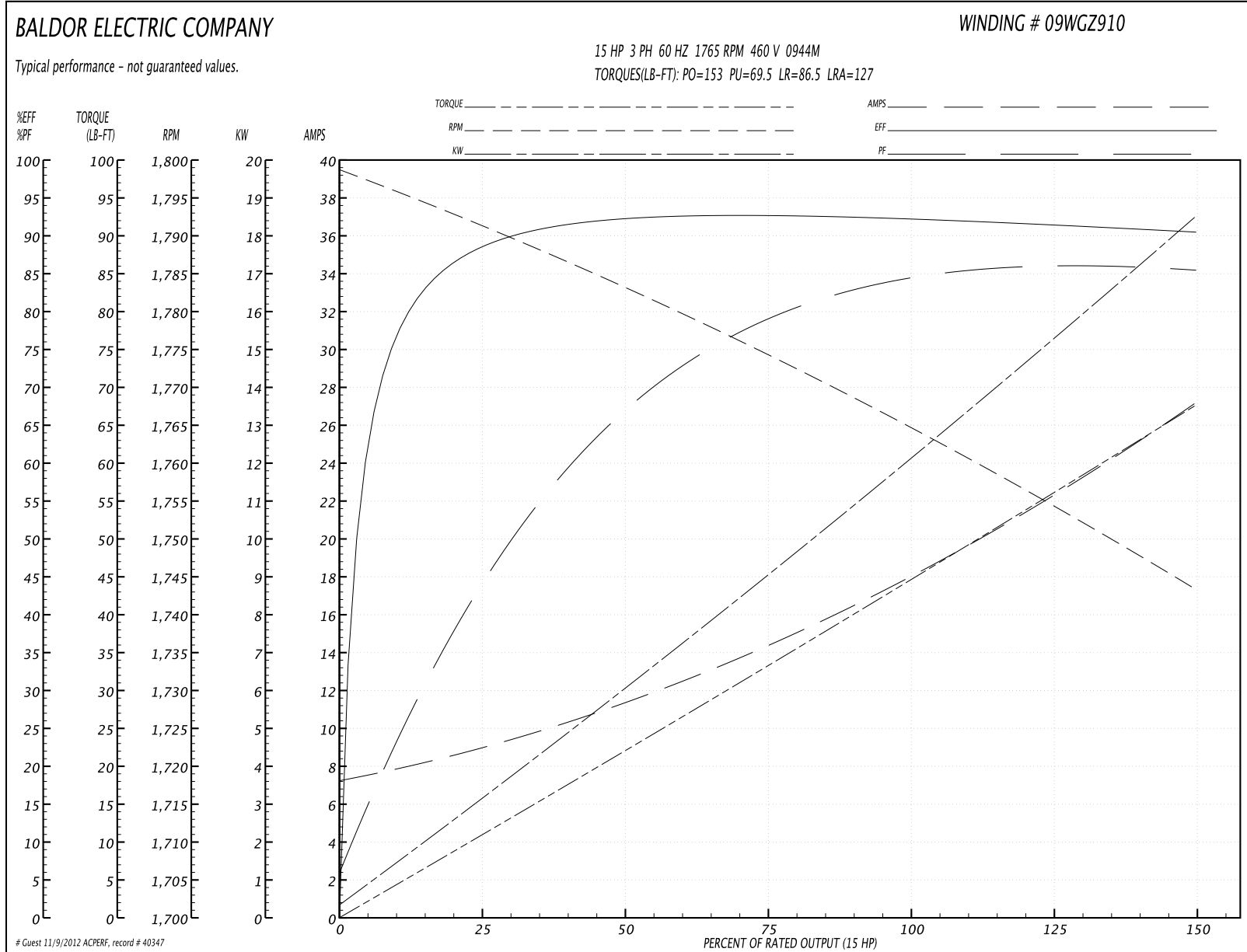

09LYP011

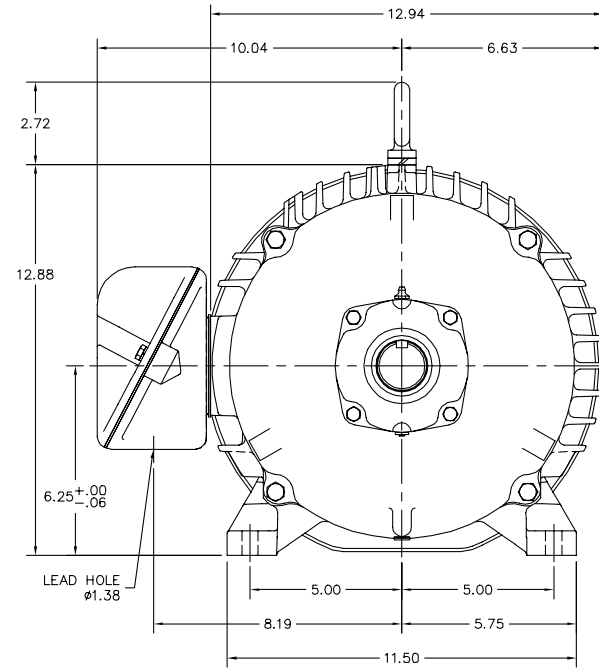
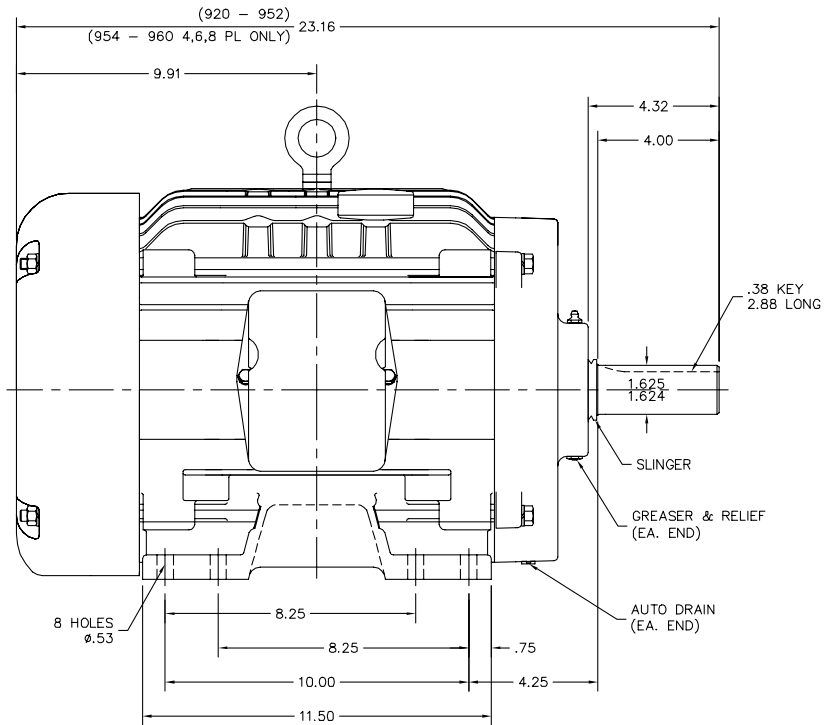

09LYP011

CUSTOMER IS RESPONSIBLE FOR DETERMINING THAT BALDOR'S PRODUCT WILL PERFORM SUITABLY IN THE INTENDED APPLICATION.

REV. DESC: CHG'D FREP, PUEP, & AUTO DRAINS		
REV. LTR: J	VERSION: 04	TDR: 000000762420
FILE: \AAA\00026\716	REVISED: 12:43:04 10/10/2012	BY: ENSTEB1
MTL: -		

BALDOR
HORZ TEFC 254-6T SUPER-E
SH 1 of 1

CD0005



LOW VOLTAGE
(2Y)



LINE

HIGH VOLTAGE
(1Y)

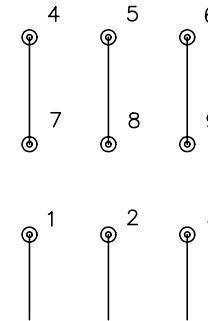

LINE

NOTES:

1. INTERCHANGE ANY TWO LINE LEADS TO REVERSE ROTATION.
2. OPTIONAL THERMOSTATS ARE PROVIDED WHEN SPECIFIED.
3. ACTUAL NUMBER OF INTERNAL PARALLEL CIRCUITS MAY BE A MULTIPLE OF THOSE SHOWN ABOVE.
4. LEAD COLORS ARE OPTIONAL. LEADS MUST ALWAYS BE NUMBERED AS SHOWN.

REV. DESC: REVISE TO SHOW OPTIONAL COLORS			
REV. LTR: E	BY: JLP	REVISED: 01/19/99 10:15	TDR: 0171435
90000		FILE: AAA00005140	MDL: -
		MTL: -	

BALDOR ELECTRIC Co.

3PH, DV, 9 LEADS

CD0005