

BALDOR® • RELIANCE

Product Information Packet

EM2394T

15HP,3520RPM,3PH,60HZ,254T,0930M,TEFC,F1

Copyright © All product information within this document is subject to Baldor Electric Company copyright © protection, unless otherwise noted.

Part Detail									
Revision:	E	Status:	PRD/A	Change #:		Proprietary:	No		
Type:	AC	Prod. Type:	0930M	Elec. Spec:	09WGZ602	CD Diagram:			
Enclosure:	TEFC	Mfg Plant:		Mech. Spec:	09P11	Layout:			
Frame:	254T	Mounting:	F1	Poles:	02	Created Date:	05-06-2010		
Base:	RG	Rotation:	R	Insulation:	F	Eff. Date:	10-17-2012		
Leads:	9#12	Literature:		Elec. Diagram:		Replaced By:			
Nameplate NP1259L									
CAT.NO.	EM2394T								
SPEC.	09P011Z602								
HP	15								
VOLTS	230/460								
AMP	35/17.5								
RPM	3520								
FRAME	254T	HZ			60	PH	3		
SER.F.	1.15	CODE			G	DES	B	CL	F
NEMA-NOM-EFF	91	PF			87				
RATING	40C AMB-CONT								
CC	010A	USABLE AT 208V			38				
DE	6309	ODE			6208				
ENCL	TEFC	SN							

Parts List		
Part Number	Description	Quantity
SA194420	SA 09P011Z602	1.000 EA
RA182007	RA 09P011Z602	1.000 EA
37FN3002C02	EXFN, PLASTIC, 6.00 OD, 1.500 ID	1.000 EA
S/P107-000-005	SUPER-E PROC'S(254/6 FR.) ZK PLANT - POL	1.000 EA
HW1002A63	WASHER, 5/8 HI-COLLAR SPRLCKWASHER	1.000 EA
09CB3002SP	CB W/1.38 LEAD HOLE FOR 37, 39, 307 & 30	1.000 EA
09GS1000SP	GASKET-CONDUIT BOX, 1/16 THICK LEXIDE	1.000 EA
10XN2520K12	1/4-20 X.75 GRD 5	2.000 EA
HW1001A25	LOCKWASHER 1/4, ZINC PLT .493 OD, .255 I	2.000 EA
09EP1101A136	PU ENDPLATE, MACH	1.000 EA
WD1000B17	KPA-8C BURNDY TERMINAL	1.000 EA
11XW1032G06	10-32 X .38, TAPTITE II, HEX WSHR SLTD U	1.000 EA
09EP1100A194	ENDPLATE, MACH	1.000 EA
XY3816A12	3/8-16 FINISHED NUT	4.000 EA
HW1001A38	LOCKWASHER 3/8, ZINC PLT .688 OD, .382 I	4.000 EA
HW5100A08	W3118-035 WVY WSHR (WB)	1.000 EA
10XN2520K28	1/4-20 X 1.75" HX HD SCRWGRADE 5, ZINC P	2.000 EA
HW1001A25	LOCKWASHER 1/4, ZINC PLT .493 OD, .255 I	2.000 EA
HW4600B44SP	V-RING SLINGER 1.500 X 2.290 X 0.280	1.000 EA
10XN2520K36	1/4-20 X 2.25" HX HD SCRWGRADE 5, ZINC P	4.000 EA
HW1001A25	LOCKWASHER 1/4, ZINC PLT .493 OD, .255 I	4.000 EA
HA3113A02	THRUBOLT 3/8-16 X 16.750	4.000 EA
HW1001A38	LOCKWASHER 3/8, ZINC PLT .688 OD, .382 I	4.000 EA
09FH4000SP	FAN COVER, STAMPED	1.000 EA

Parts List (continued)		
Part Number	Description	Quantity
HA2081A05	SPACER TUBE, 309 FAN HSG, 2.00 LONG	4.000 EA
XY3816A12	3/8-16 FINISHED NUT	4.000 EA
HW1001A38	LOCKWASHER 3/8, ZINC PLT .688 OD, .382 I	4.000 EA
09CB3501SP	CONDUIT BOX LID FOR 09CB3001 & 09CB3002	1.000 EA
09GS1013SP	09 GS FOR 09CB3501 LID - LEXIDE	1.000 EA
51XW2520A12	.25-20 X .75, TAPTITE II, HEX WSHR SLTD	2.000 EA
HW2501G25	KEY, 3/8 SQ X 2.875	1.000 EA
LB1115	LABEL,LIFTING DEVICE	1.000 EA
LB5040	INSTRUCTION TAG, AC & DC	1.000 EA
HA4051A00	PLASTIC CAP FOR GREASE FITTING	1.000 EA
HW4500A05	1669B ALEM/UNIV860 GR FTG X	1.000 EA
HW4500A17	317400 ALEMITE GREASE RELIEF	1.000 EA
HA4066A01	PUSH IN T-DRAIN FITTING (BLACK)	1.000 EA
MJ1000A75	GREASE, POLYREX EM EXXON	0.080 LB
HA4051A00	PLASTIC CAP FOR GREASE FITTING	1.000 EA
HW4500A03	GREASE FITTING, .125 NPT 1610(ALEMITE) 8	1.000 EA
HW4500A17	317400 ALEMITE GREASE RELIEF	1.000 EA
HA4066A01	PUSH IN T-DRAIN FITTING (BLACK)	1.000 EA
HW2500A25	WOODRUFF KEY USA #1008 #BLOW CARBON STEE	1.000 EA
51XB1214A20	12-14X1.25 HXWSSLD SERTYB	1.000 EA
MG1000Y03	WILKO 689.710 GOLD PAINT SUPER E	0.050 GA
85XU0407A04	#4-7 X 1/4 DRIVE PIN	2.000 EA
LB1119	WARNING LABEL	1.000 EA
LB1125C02	SUPER-E (STOCK CTN LABEL SUPER-E WITH FL	4.000 EA

Parts List (continued)		
Part Number	Description	Quantity
LB1357	ENERGY GUIDE LABEL (BOX LABEL)	2.000 SH
LC0181	CONNECTION LABEL	1.000 EA
NP1259L	ALUM SUPER-E UL CSA-EEV CC NEMA PREMIUM	1.000 EA
09PA1000	PACKAGING GROUP COMBINED PRINT	1.000 EA

Accessories		
Part Number	Description	Multiplier
09-1309	C FACE KIT (kit may require RB3001A01)	A8

Performance Data at 460V, 60Hz, 15.0HP (Typical performance - Not guaranteed values)

General Characteristics			
Full Load Torque:	22.1 LB-FT	Start Configuration:	DOL
No-Load Current:	5.58 Amps	Break-Down Torque:	105.0 LB-FT
Line-line Res. @ 25°C.:	0.68654 Ohms A Ph / 0.0 Ohms B Ph	Pull-Up Torque:	26.2 LB-FT
Temp. Rise @ Rated Load:	63 C	Locked-Rotor Torque:	36.3 LB-FT
Temp. Rise @ S.F. Load:	78 C	Starting Current:	110.0 Amps

Load Characteristics							
% of Rated Load	25	50	75	100	125	150	S.F.
Power Factor:	55.0	77.0	85.0	87.0	89.0	89.0	88.0
Efficiency:	86.4	91.0	91.6	91.0	90.0	88.6	90.4
Speed:	3582.7	3563.6	3542.7	3520.9	3495.8	3468.3	3506.0
Line Amperes:	6.93	9.78	13.5	17.5	21.6	26.4	20.0

Performance Graph at 460V, 60Hz, 15.0HP Typical performance - Not guaranteed values

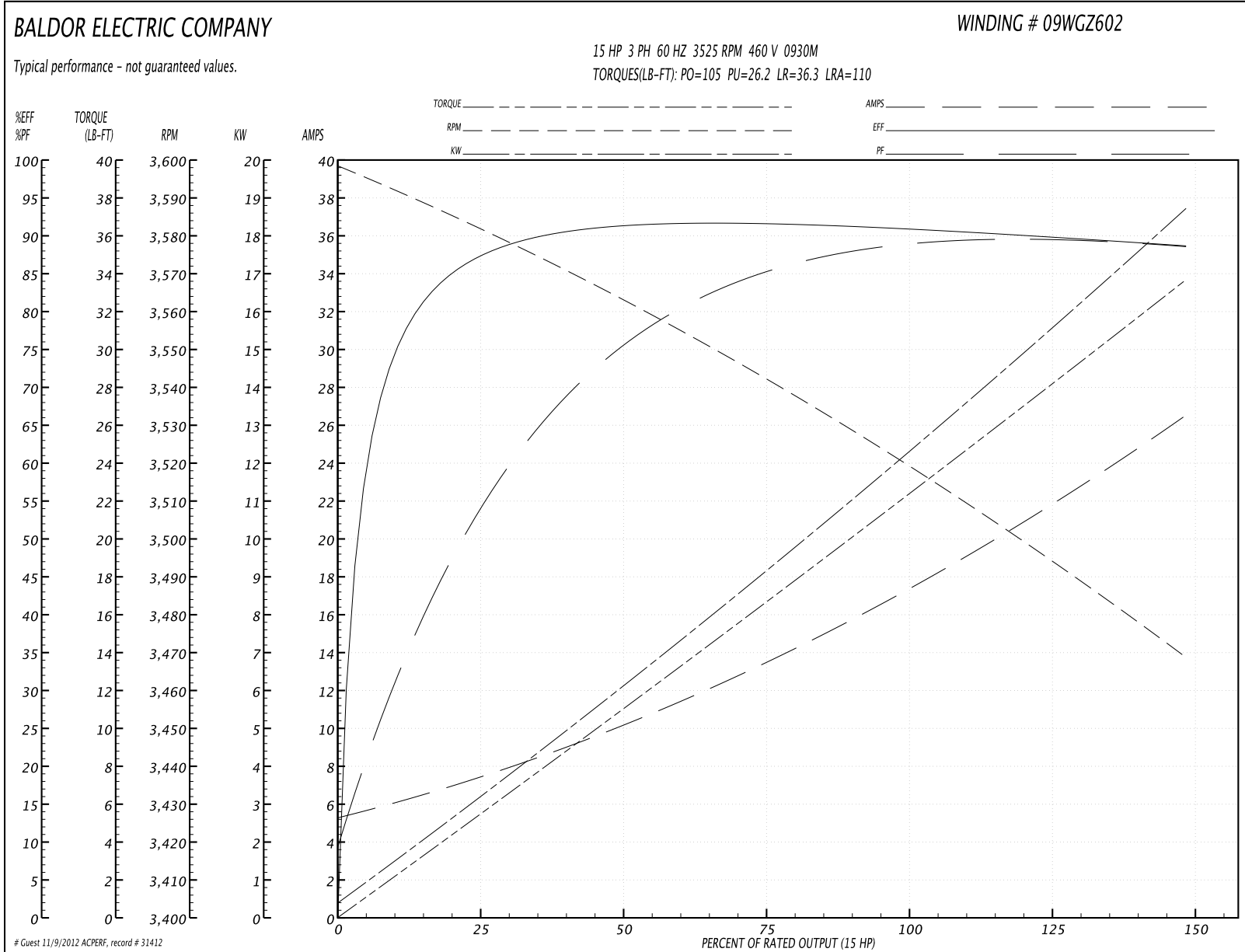

09LYP011

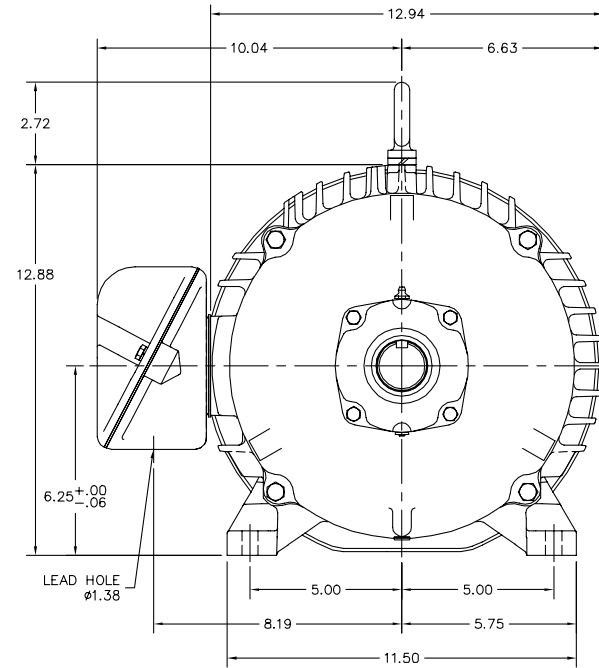
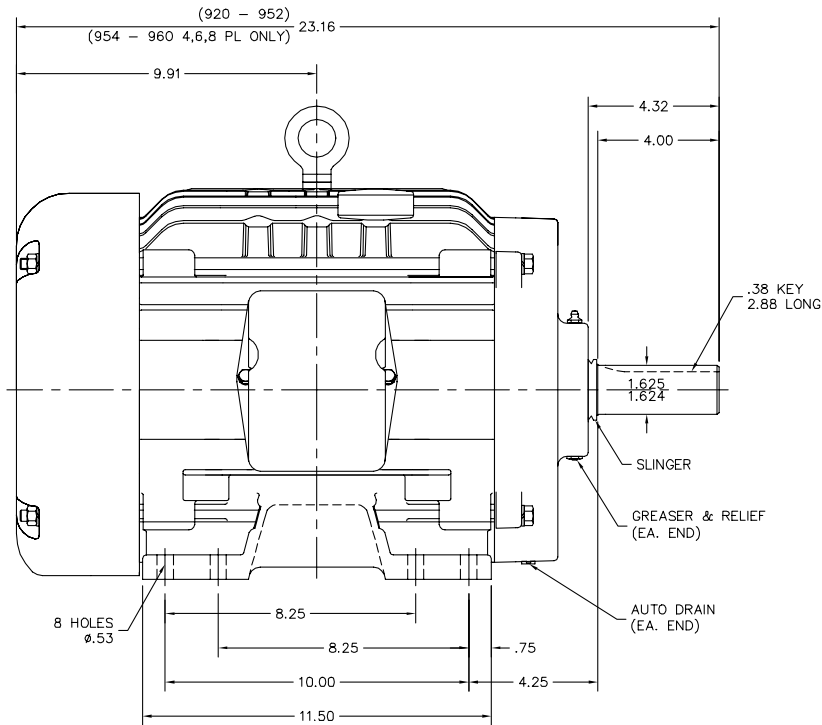

09LYP011

CUSTOMER IS RESPONSIBLE FOR DETERMINING THAT BALDOR'S PRODUCT WILL PERFORM SUITABLY IN THE INTENDED APPLICATION.

REV. DESC: CHG'D FREP, PUEP, & AUTO DRAINS	VERSION: 04	TDR: 000000762420
REV. LTR: J	REVISD: 12:43:04 10/10/2012	BY: ENSTEB1
FILE: \AAA\00026\716		
MTL: -		

BALDOR
 HORZ TEFC 254-6T SUPER-E
 SH 1 of 1

CD0180



LOW VOLTAGE
(2D)



LINE

HIGH VOLTAGE
(1D)

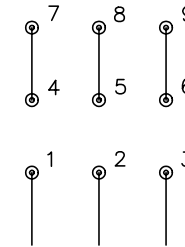

LINE

NOTES:

1. INTERCHANGE ANY TWO LINE LEADS TO REVERSE ROTATION.
2. OPTIONAL THERMOSTATS ARE PROVIDED WHEN SPECIFIED.
3. ACTUAL NUMBER OF INTERNAL PARALLEL CIRCUITS MAY BE A MULTIPLE OF THOSE SHOWN ABOVE.
4. LEAD COLORS ARE OPTIONAL. LEADS MUST ALWAYS BE NUMBERED AS SHOWN.

REV. DESC: REVISE TO SHOW OPTIONAL COLORS			
REV. LTR: C	BY: JLP	REVISED: 01/21/99 2:28	TDR: 0171435
0810D0		FILE: AAA00005148	MDL: -
		MTL: -	

BALDOR ELECTRIC Co.

3PH, DV, 9 LEADS, DELTA CONNECTION

CD0180