

BALDOR® • RELIANCE

Product Information Packet

EM3661T

3HP,1755RPM,3PH,60HZ,182T,0632M,TEFC,F1

Copyright © All product information within this document is subject to Baldor Electric Company copyright © protection, unless otherwise noted.

Part Detail							
Revision:	C	Status:	PRD/A	Change #:		Proprietary:	No
Type:	AC	Prod. Type:	0632M	Elec. Spec:	06WGX181	CD Diagram:	
Enclosure:	TEFC	Mfg Plant:		Mech. Spec:	06H002	Layout:	
Frame:	182T	Mounting:	F1	Poles:	04	Created Date:	04-26-2010
Base:	RG	Rotation:	R	Insulation:	F	Eff. Date:	10-07-2011
Leads:	9#16	Literature:		Elec. Diagram:		Replaced By:	

Nameplate NP1259L									
CAT.NO.	EM3661T								
SPEC.	06H002X181G1								
HP	3								
VOLTS	208-230/460								
AMP	8.6-8.2/4.1								
RPM	1755								
FRAME	182T	HZ	60	PH	3				
SER.F.	1.15	CODE	J	DES	B	CL	F		
NEMA-NOM-EFF	89.5	PF	77						
RATING	40C AMB-CONT								
CC	010A	USABLE AT 208V							
DE	6206	ODE	6205						
ENCL	TEFC	SN							

Parts List		
Part Number	Description	Quantity
SA193933	SA 06H002X181G1	1.000 EA
RA181527	RA 06H002X181G1	1.000 EA
36FN3000C01SP	EXFN, PLASTIC, 5.25 OD, .912 ID	1.000 EA
S/P107-000-001	SUPER E PROC'S-FS & WS PLTS-POLYREX EM G	1.000 EA
HW3201A05	3/8-16 EYEBOLT	1.000 EA
06CB3000	CONDUIT BOX CAST	1.000 EA
06GS1000	GASKET, CONDUIT BOX	1.000 EA
51XW2520A12	.25-20 X .75, TAPTITE II, HEX WSHR SLTD	2.000 EA
11XW1032G06	10-32 X .38, TAPTITE II, HEX WSHR SLTD U	1.000 EA
HW3001B01	003SS CUP WASHER, FOR #8 SCREW	1.000 EA
36EP1101A21	FR ENDPLATE, MACH	1.000 EA
HW4500A01	1641B(ALEMITE)400 UNIV, GREASE FITT	1.000 EA
HW4500A17	317400 ALEMITE GREASE RELIEF	1.000 EA
HW5100A05	WVY WSHR F/205 & 304 BRGS	1.000 EA
36EP1100A07	PU ENDPLATE MACH W/GREASER & RELIEF	1.000 EA
HW4500A01	1641B(ALEMITE)400 UNIV, GREASE FITT	1.000 EA
HW4500A17	317400 ALEMITE GREASE RELIEF	1.000 EA
HA3101A53	THRUBOLT 1/4-20 X 10.50	4.000 EA
XY2520A12	1/4-20 HEX NUT, DIRECTIONAL SERRATIONS	4.000 EA
36FH4009A31	IEC FH W/GREASER & SPL NOTCH, W/ AUTOPHE	1.000 EA
51XW1032A06	10-32 X .38, TAPTITE II, HEX WSHR SLTD S	3.000 EA
06CB3500	CONDUIT BOX LID - ALUMINUM DIE CAST	1.000 EA
06GS1001	GASKET, CONDUIT BOX LID	1.000 EA
51XW2520A12	.25-20 X .75, TAPTITE II, HEX WSHR SLTD	2.000 EA

Parts List (continued)		
Part Number	Description	Quantity
HW2501E16	3KEY, 1/4 SQ X 1.750	1.000 EA
HA7000A02	KEY RETAINER RING, 1 1/8 DIA, 1 3/8 DIA	1.000 EA
LB1115	LABEL,LIFTING DEVICE	1.000 EA
85XU0407S04	4X1/4 U DRIVE PIN STAINLESS	2.000 EA
MJ1000A75	GREASE, POLYREX EM EXXON	0.050 LB
51XB1214A16	12-14X1.00 HXWSSLD SERTYB	1.000 EA
MG1000Y03	WILKO 689.710 GOLD PAINT SUPER E	0.028 GA
LC0005E01	CONN.DIA./WARNING LABEL (LC0005/LB1119)	1.000 EA
LB1125C02	SUPER-E (STOCK CTN LABEL SUPER-E WITH FL	1.000 EA
LB1357	ENERGY GUIDE LABEL (BOX LABEL)	1.000 SH
NP1259L	ALUM SUPER-E UL CSA-EEV CC NEMA PREMIUM	1.000 EA
36PA1001	PACKAGING GROUP	1.000 EA

Accessories		
Part Number	Description	Multiplier
36-1749	C FACE KIT	A8

Performance Data at 460V, 60Hz, 3.0HP (Typical performance - Not guaranteed values)

General Characteristics			
Full Load Torque:	9.06 LB-FT	Start Configuration:	DOL
No-Load Current:	2.14 Amps	Break-Down Torque:	33.1 LB-FT
Line-line Res. @ 25°C.:	3.92 Ohms A Ph / 0.0 Ohms B Ph	Pull-Up Torque:	18.2 LB-FT
Temp. Rise @ Rated Load:	35 C	Locked-Rotor Torque:	20.4 LB-FT
Temp. Rise @ S.F. Load:	42 C	Starting Current:	29.8 Amps

Load Characteristics							
% of Rated Load	25	50	75	100	125	150	S.F.
Power Factor:	38.0	58.0	70.0	77.0	81.0	83.0	79.0
Efficiency:	83.6	88.9	90.1	89.9	89.1	87.8	89.4
Speed:	1789.5	1779.3	1768.8	1757.0	1744.4	1730.0	1749.0
Line Amperes:	2.34	2.79	3.39	4.1	4.91	5.86	4.59

Performance Graph at 460V, 60Hz, 3.0HP Typical performance - Not guaranteed values

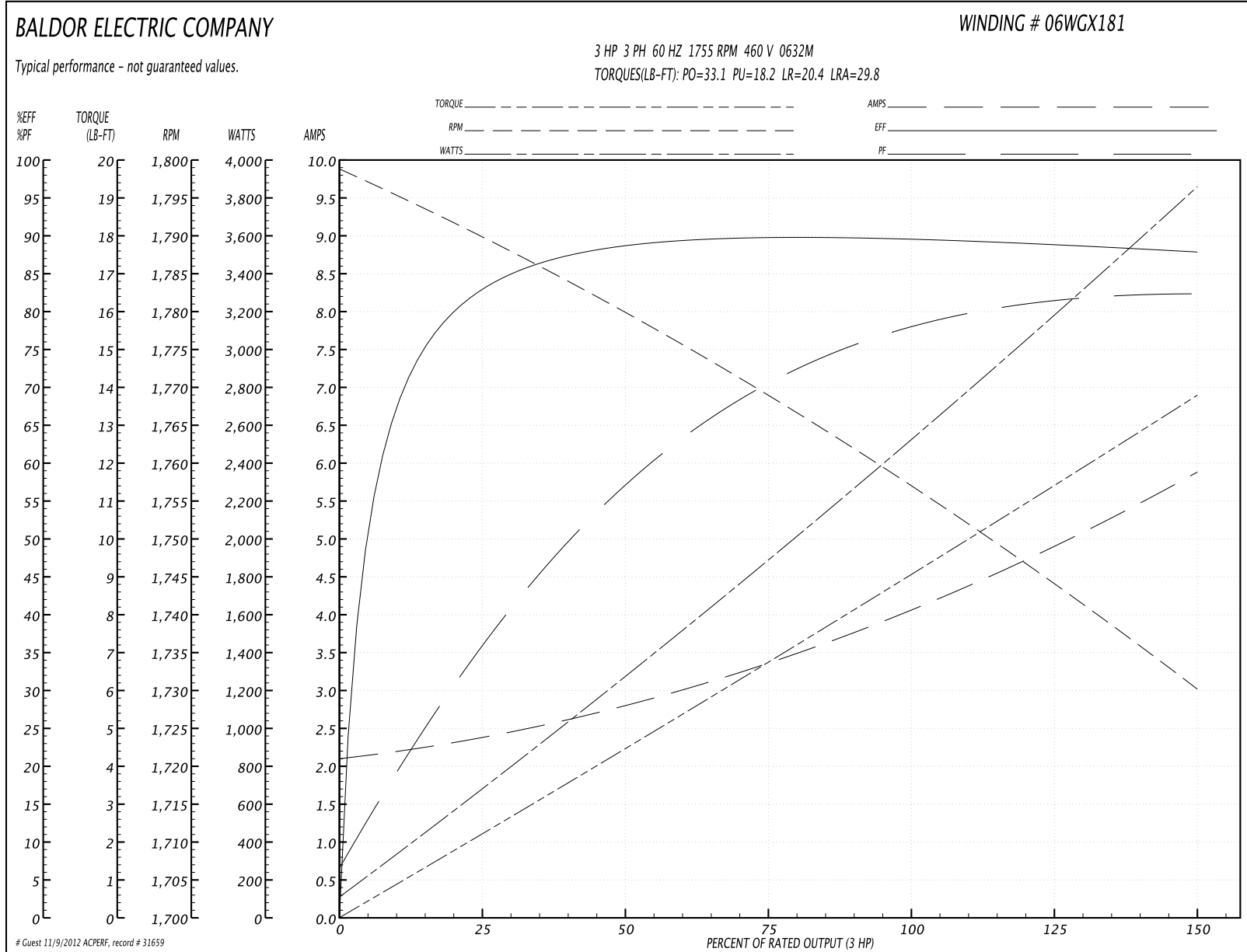

06LYH002

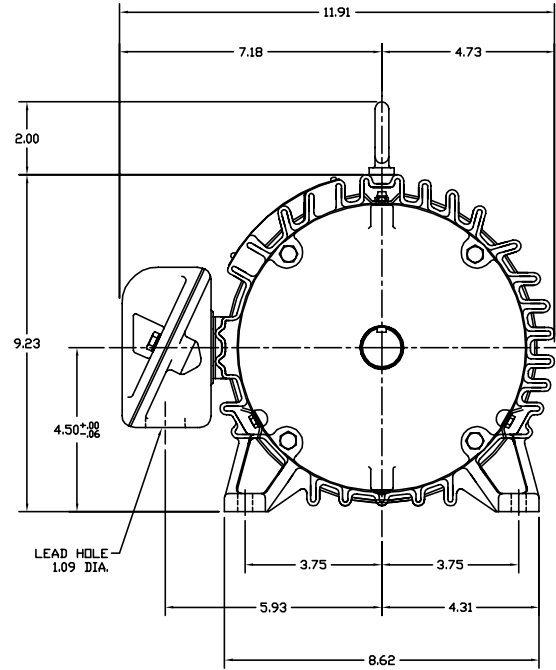
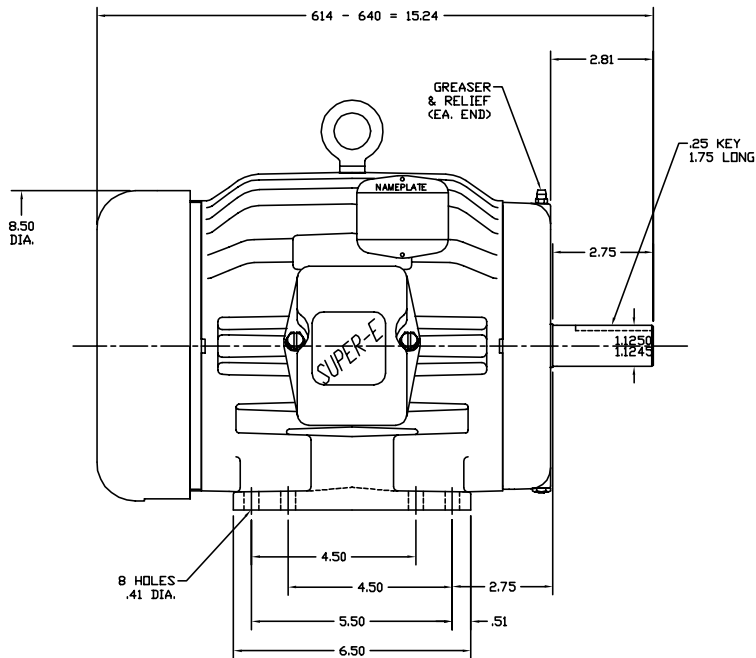

CUSTOMER IS RESPONSIBLE FOR DETERMINING THAT MOTOR PERFORMANCE IS SUITABLE IN THE APPLICATION.

REV. DESC: OMITTED LB1098 LEADER			
REV. LTR: K	BY: SSS	REVISED: 15:54:03 08/22/2001	TDR: 247831
FILE: AAA00014115		REF: 06LYH002	
MTL: -			

BALDOR ELECTRIC Co.

HDRZ 182-4T TEFC 306M

06LYH002

CD0005



LOW VOLTAGE
(2Y)

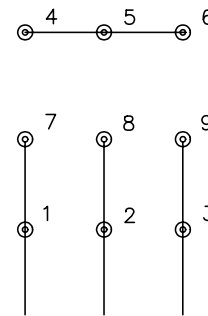

LINE

HIGH VOLTAGE
(1Y)

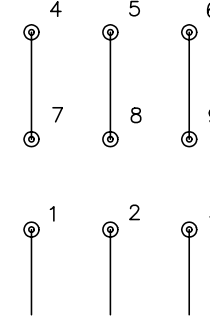

LINE

NOTES:

1. INTERCHANGE ANY TWO LINE LEADS TO REVERSE ROTATION.
2. OPTIONAL THERMOSTATS ARE PROVIDED WHEN SPECIFIED.
3. ACTUAL NUMBER OF INTERNAL PARALLEL CIRCUITS MAY BE A MULTIPLE OF THOSE SHOWN ABOVE.
4. LEAD COLORS ARE OPTIONAL. LEADS MUST ALWAYS BE NUMBERED AS SHOWN.

REV. DESC: REVISE TO SHOW OPTIONAL COLORS			
REV. LTR: E	BY: JLP	REVISED: 01/19/99 10:15	TDR: 0171435
90000		FILE: AAA00005140	MDL: -
		MTL: -	

BALDOR ELECTRIC Co.

3PH, DV, 9 LEADS

CD0005