

BALDOR® • RELIANCE

Product Information Packet

EMM3711

7.5KW,3490RPM,3PH,60HZ,D132S,3729M,TEFC

Copyright © All product information within this document is subject to Baldor Electric Company copyright © protection, unless otherwise noted.

Part Detail							
Revision:	A	Status:	PRD/A	Change #:		Proprietary:	No
Type:	AC	Prod. Type:	3729M	Elec. Spec:	37WGS864	CD Diagram:	
Enclosure:	TEFC	Mfg Plant:		Mech. Spec:	37G816	Layout:	
Frame:	D132S	Mounting:	B3	Poles:	02	Created Date:	03-16-2012
Base:	RG	Rotation:	R	Insulation:	F	Eff. Date:	03-29-2012
Leads:	9#14	Literature:		Elec. Diagram:		Replaced By:	
Nameplate NP1159L							
CAT.NO.	EMM3711						
SPEC.	37G816S864G1						
IEC FRAME	D132S	KW				7.5KW	
VOLTS	208-230/460						
AMP	24.9-23.6/11.8						
RPM	3490	ENCL				TEFC	
HZ	60	PH				3	CL F
SER.F.	1.15	DES				B	CODE G
NEMA-NOM-EFF	90.2	I.P.				54	
RATING	40C AMB-CONT						
CC	010A	USABLE AT 208V					
DE	6208	ODE				6206	
SER. #							

Parts List		
Part Number	Description	Quantity
SA241154	SA 37G816S864G1	1.000 EA
RA228073	RA 37G816S864G1	1.000 EA
36FN3000C02	EXFN, PLASTIC, 5.25 OD, 1.175 ID	1.000 EA
S/P107-000-001	SUPER E PROC'S-FS & WS PLTS-POLYREX EM G	1.000 EA
HW3200A01	3/8-16X3/4 I-BLT WELDED F/S	1.000 EA
37CB3005A04	37 CB .75 NPT @ 6:00	1.000 EA
37GS1000SP	GASKET, CONDUIT BOX STD., .06 THICK LEXI	1.000 EA
51XW2520A12	.25-20 X .75, TAPTITE II, HEX WSHR SLTD	2.000 EA
11XW1032G06	10-32 X .38, TAPTITE II, HEX WSHR SLTD U	1.000 EA
37EP3101A01SP	FR ENDPLATE,TEFC, 37 L&M, W/GREASER	1.000 EA
HW4500A01	1641B(ALEMITE)400 UNIV, GREASE FITT	1.000 EA
HW5100A06	W2420-025 WVY WSHR (WB)	1.000 EA
37EP3100A11	PU ENDPLATE, MACH	1.000 EA
HW4500A01	1641B(ALEMITE)400 UNIV, GREASE FITT	1.000 EA
XY3118A12	5/16-18 HEX NUT DIRECTIONAL SERRATION	4.000 EA
51XB1214A20	12-14X1.25 HXWSSLD SERTYB	1.000 EA
07FH4007SP	IEC FH W/GRSR, NOTCH @ 6:00 & 3 FAN CVR	1.000 EA
51XW1032A06	10-32 X .38, TAPTITE II, HEX WSHR SLTD S	3.000 EA
37CB4516	LIPPED LID FOR 37 FRAME NEC KOBX	1.000 EA
37GS1008SP	37 GS FOR CB LID - LEXIDE	1.000 EA
51XW0832A07	8-32 X .44, TAPTITE II, HEX WSHR SLTD SE	4.000 EA
HA1005A12SP	SLINGER, OD 2.50, ID 1.433, 208 BRG	1.000 EA
HW2505B19	KEY, 8 X 10 MM X 2.125 IN	1.000 EA
85XU0407S04	4X1/4 U DRIVE PIN STAINLESS	2.000 EA

Parts List (continued)		
Part Number	Description	Quantity
LB1115	LABEL,LIFTING DEVICE	1.000 EA
MJ1000A75	GREASE, POLYREX EM EXXON	0.050 LB
MG1000Y03	WILKO 689.710 GOLD PAINT SUPER E	0.028 GA
HA3104A14	THRUBOLT- 5/16-18 X12.125(OHIO)	4.000 EA
LC0005E01	CONN.DIA./WARNING LABEL (LC0005/LB1119)	1.000 EA
LB1125C02	SUPER-E (STOCK CTN LABEL SUPER-E WITH FL	1.000 EA
LB1357	ENERGY GUIDE LABEL (BOX LABEL)	1.000 SH
NP1159L	SS SUPER-E IEC UL CSA CC	1.000 EA
G0PA1000	PACKAGING GROUP	1.000 EA

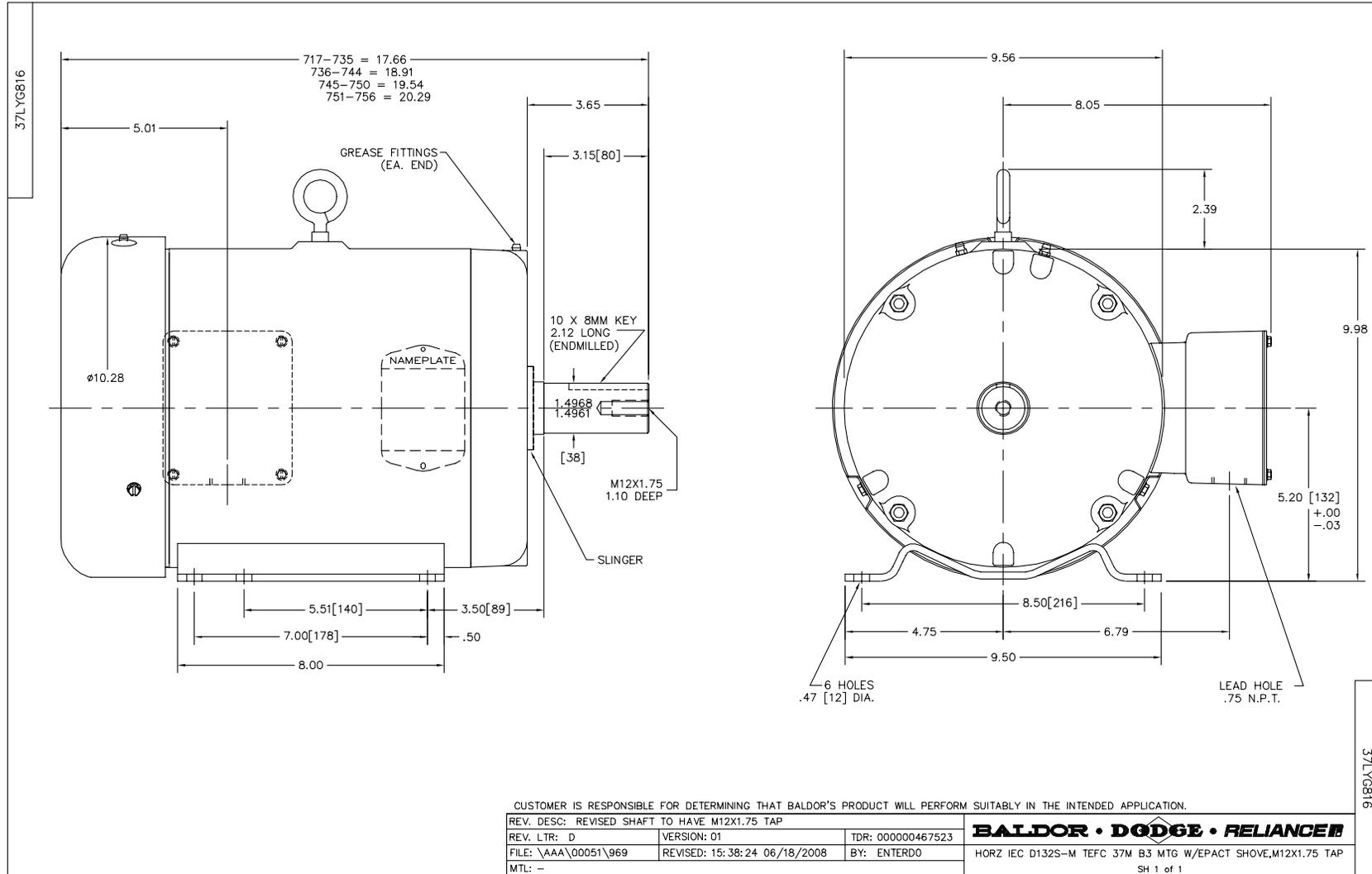

CD0005

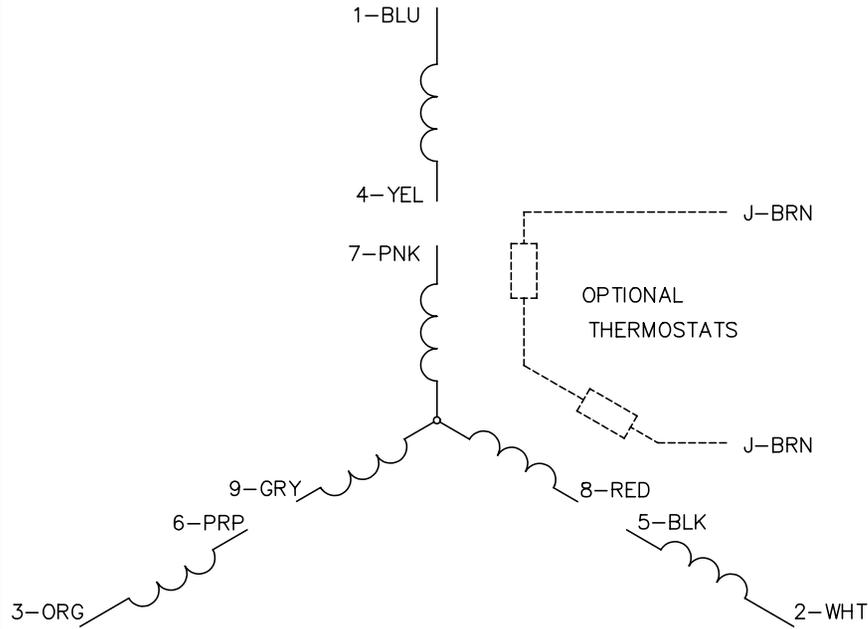

LOW VOLTAGE (2Y)

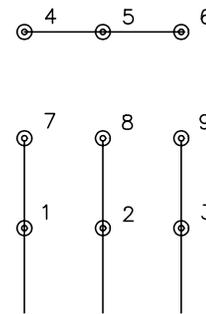

LINE

HIGH VOLTAGE (1Y)

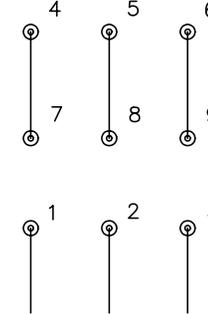

LINE

NOTES:

1. INTERCHANGE ANY TWO LINE LEADS TO REVERSE ROTATION.
2. OPTIONAL THERMOSTATS ARE PROVIDED WHEN SPECIFIED.
3. ACTUAL NUMBER OF INTERNAL PARALLEL CIRCUITS MAY BE A MULTIPLE OF THOSE SHOWN ABOVE.
4. LEAD COLORS ARE OPTIONAL. LEADS MUST ALWAYS BE NUMBERED AS SHOWN.

REV. DESC: REVISE TO SHOW OPTIONAL COLORS			
REV. LTR: E	BY: JLP	REVISED: 01/19/99 10:15	TDR: 0171435
90000		FILE: AAA00005140	MDL: -
		MTL: -	

BALDOR ELECTRIC Co.

3PH, DV, 9 LEADS

CD0005